



Specification for Approval

PRODUCT NUMBER: HTOLED-130-A
PRODUCT DESCRIPTION: RGS13128064WR001

CUSTOMER
APPROVED BY
DATE:

RITDISPLAY CORP. APPROVED



REVISION RECORD

REV.	REVISION DESCRIPTION	REV. DATE	REMARK
A01	INITIAL RELEASE	2016. 03. 25	
A02	■ Modify CIE specifications ■ Add outgoing inspection provision	2018. 05. 03	Page 7 & 19~24



CONTENTS

ITEM	PAGE
1. SCOPE	4
2. WARRANTY	4
3. FEATURES	4
4. MECHANICAL DATA	5
5. MAXIMUM RATINGS	6
6. ELECTRICAL CHARACTERISTICS	6
6.1 D.C ELECTRICAL CHARACTERISTICS	
6.2 ELECTRO-OPTICAL CHARACTERISTICS	
7. LIFETIME SPECIFICATION	8
8. INTERFACE	9
8.1 FUNCTION BLOCK DIAGRAM	
8.2 PANEL LAYOUT DIAGRAM	
8.3 PIN ASSIGNMENTS	
8.4 GRAPHIC DISPLAY DATA RAM (GDDRAM)	
8.5 INTERFACE TIMING CHART	
9. POWER ON / OFF SEQUENCE & APPLICATION CIRCUIT	13
9.1 POWER ON / OFF SEQUENCE	
9.2 APPLICATION CIRCUIT	
9.3 COMMAND TABLE	
10. RELIABILITY TEST CONDITIONS	16
11. EXTERNAL DIMENSION	17
12. PACKING SPECIFICATION	18
13. OUTGOING INSPECTION PROVISION	19
14. APPENDIXES	25



1. SCOPE

The purpose of this specification is to define the general provisions and quality requirements that apply to the supply of display cells manufactured by RiTdisplay. This document, together with the Module Ass'y Drawing, is the highest-level specification for this product. It describes the product, identifies supporting documents and contains specifications.

2. WARRANTY

HTdisplay warrants that the products delivered pursuant to this specification (or order) will conform to the agreed specifications for twelve (12) months from the shipping date ("Warranty Period"). HTdisplay is obligated to repair or replace the products which are found to be defective or inconsistent with the specifications during the Warranty Period without charge, on condition that the products are stored in the original packages at 25 °C±5 °C, 55%±10%RH or used as the conditions specified in the specifications.

Nevertheless, HTdisplay is not obligated to repair or replace the products without charge if the defects or inconsistency are caused by the force majeure or the reckless behaviors of the customer.

After the Warranty Period, all repairs or replacements of the products are subject to charge.

3. FEATURES

- Small molecular organic light emitting diode.
- Color : White
- Panel matrix : 128x64
- Driver IC : SH1106G
- Excellent quick response time.
- Extremely thin thickness for best mechanism design : 1.427mm
- High contrast : 2000:1
- Wide viewing angle : 160°
- 8-bit 6800/8080-series parallel interface, 3/4 wire Serial Peripheral Interface, I²C Interface.
- Wide range of operating temperature : -40 to 70 °C
- Anti-glare polarizer.



4. MECHANICAL DATA

NO	ITEM	SPECIFICATION	UNIT
1	Dot Matrix	128 (W) x 64 (H)	dot
2	Dot Size	0.21 (W) x 0.21 (H)	mm ²
3	Dot Pitch	0.23 (W) x 0.23 (H)	mm ²
4	Aperture Rate	83.3	%
5	Active Area	29.42 (W) x 14.7 (H)	mm ²
6	Panel Size	34.5 (W) x 23 (H)	mm ²
7*	Panel Thickness	1.22 ± 0.1	mm
8	Module Size	34.5 (W) x 35 (H) x 1.427 (D)	mm ³
9	Diagonal A/A size	1.29	inch
10	Module Weight	2.22 ± 10%	gram

* Panel thickness includes substrate glass, cover glass and UV glue thickness.



5. MAXIMUM RATINGS

ITEM	MIN	MAX	UNIT	Condition	Remark
Supply Voltage (V_{DD})	-0.3	3.6	V	$T_a = 25^\circ\text{C}$	IC maximum rating
Supply Voltage (V_{BAT})	-0.3	4.8	V	$T_a = 25^\circ\text{C}$	IC maximum rating
Supply Voltage (V_{CC})	8	14.5	V	$T_a = 25^\circ\text{C}$	IC maximum rating
Operating Temp.	-40	70	$^\circ\text{C}$	-	-
Storage Temp	-40	85	$^\circ\text{C}$	-	Note (2)

Note:

- (1) Maximum ratings are those values beyond which damages to the OLED module may occur. The OLED functional operation should be restricted to the limits in the section 6. Electrical Characteristics tables.
- (2) The defined temperature ranges do not include the polarizer. The maximum withstood temperature of the polarizer should be 80°C .

6. ELECTRICAL CHARACTERISTICS

6.1 D.C ELECTRICAL CHARACTERISTICS

SYMBOL	PARAMETER	TEST CONDITION	MIN	TYP	MAX	UNIT
V_{DD}	Logic Supply Voltage	$T_a = 25^\circ\text{C}$	1.65	-	3.5	V
V_{BAT}	Charge Pump Regulator Supply Voltage	$T_a = 25^\circ\text{C}$	3.5	-	4.7	V
V_{CC}	Operating Voltage (for OLED panel) (Charge Pump)	$T_a = 25^\circ\text{C}$	6.4	-	9	V
V_{OH}	High Logic Output Level	$I_{OH} = -0.5\text{mA}$	$0.8 \cdot V_{DD}$	-	V_{DD}	V
V_{OL}	Low Logic Output Level	$I_{OL} = 0.5\text{mA}$	V_{SS}	-	$0.2 \cdot V_{DD}$	V
V_{IH}	High Logic Input Level	-	$0.8 \cdot V_{DD}$	-	V_{DD}	V
V_{IL}	Low Logic Input Level	-	V_{SS}	-	$0.2 \cdot V_{DD}$	V



6.2 ELECTRO-OPTICAL CHARACTERISTICS

PANEL ELECTRICAL SPECIFICATIONS

PARAMETER	MIN	TYP.	MAX	UNITS	COMMENTS
Normal mode current (IBAT) (Charge Pump)	-	35	37	mA	All pixels on (1)
	-	18	19	mA	20% pixels on (1)
Standby mode current (IBAT) (Charge Pump)	-	8	9	mA	Standby mode 10% pixels on (2)
IDD sleep mode current	-	-	5	uA	Sleep mode Current (3)
IBAT sleep mode current (Charge Pump)	-	-	5	uA	Sleep mode Current (3)
Normal Luminance (Charge Pump)	60	80	-	cd/m ²	Display Average
Standby Luminance (Charge Pump)	-	55	-	cd/m ²	Display Average
CIE _x (White)	0.23	0.27	0.31		x, y (CIE 1931)
CIE _y (White)	0.25	0.29	0.33		
Dark Room Contrast	2000:1				
Viewing Angle	160			degree	
Response Time		10		μs	

(1) Normal mode condition : (Charge Pump)

- V_{BAT} = 3.6V
- Contrast setting : 0x80
- Frame rate : 105Hz
- Duty setting : 1/64

(2) Standby mode condition : (Charge Pump)

- V_{BAT} = 3.6V
- Contrast setting : 0x00
- Frame rate : 105Hz
- Duty setting : 1/64

(3) Sleep mode condition :

When send 0xae command OLED display off and memory data will be maintained.

(4) Wake up condition :

When send 0xaf command OLED will be turned on.



7. LIFETIME SPECIFICATION

ITEM	MIN	UNIT	Condition	Remark
Life Time	32,000	Hrs	60 cd/m ² , 50% alternating checkerboard	(Charge pump) Note (1)
Life Time	24,000	Hrs	80 cd/m ² , 50% alternating checkerboard	(Charge pump) Note (2)

Note:

(A) Under $V_{BAT} = 3.6V$ (Charge Pump), $T_a = 25^\circ C$, 50% RH.

(B) Life time is defined the amount of time when the luminance has decayed to less than 50% of the initial measured luminance.

(1) Setting of 60 cd/m² : (Charge Pump)

- Contrast setting : 0x11
- Frame rate : 105Hz
- Duty setting : 1/64

(2) Setting of 80 cd/m² : (Charge Pump)

- Contrast setting : 0x80
- Frame rate : 105Hz
- Duty setting : 1/64

8. INTERFACE

8.1 FUNCTION BLOCK DIAGRAM

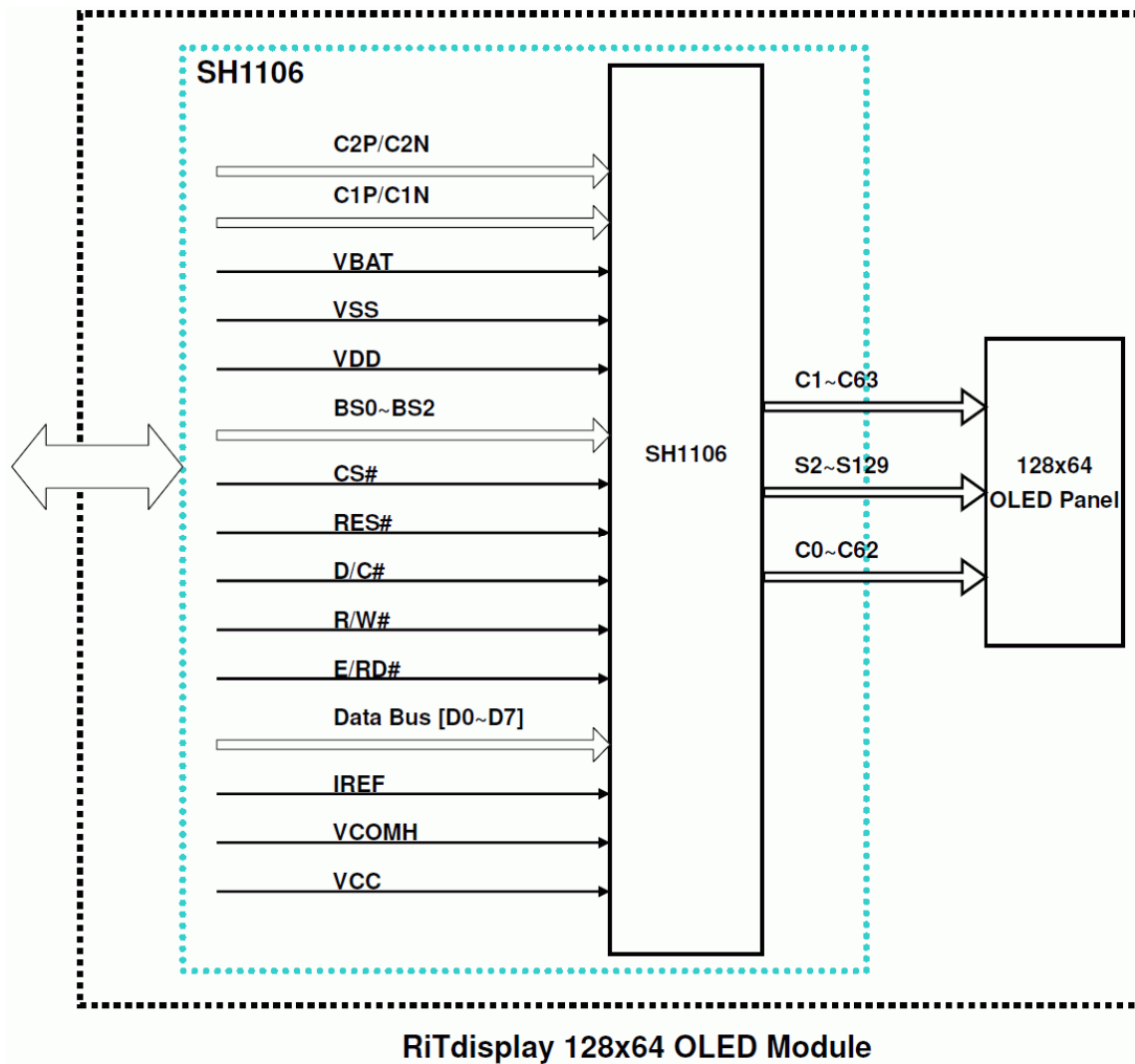

8.2 PANEL LAYOUT DIAGRAM

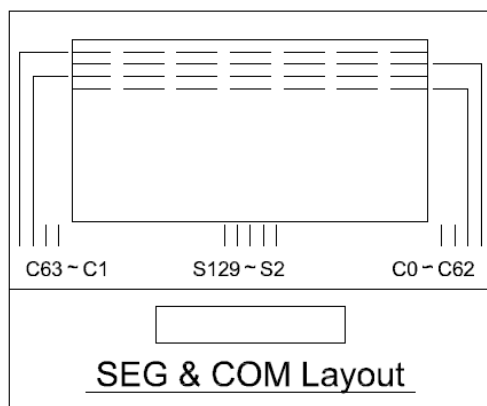



8.3 PIN ASSIGNMENTS

PIN NO.	PIN NAME	DESCRIPTION
1	N.C.(GND)	Reserved pin. It should be connected to VSS.
2	C2P	C2P/C2N – Pin for charge pump capacitor; Connect to each other with a capacitor.
3	C2N	
4	C1P	C1P/C1N – Pin for charge pump capacitor; Connect to each other with a capacitor.
5	C1N	
6	VBAT	Power supply for charge pump regulator circuit.
7	VSS	Ground pin.
8	VSS	Ground pin.
9	VDD	Power supply pin for core logic operation.
10	BS0	MCU bus interface selection pins.
11	BS1	
12	BS2	
13	CS#	This pin is the chip select input connecting to the MCU.
14	RES#	This pin is reset signal input.
15	D/C#	This pin is Data/Command control pin connecting to the MCU.
16	R/W#	This pin is read / write control input pin connecting to the MCU interface. 8080: data write enable pin; 6800:Read/Write select pin. When serial or I ² C interface is selected, this pin must be connected to VSS.
17	E/RD#	8080: data read enable pin; 6800:Read/Write enable pin. When serial or I ² C interface is selected, this pin must be connected to VSS.
18	D0	This is an 8-bit bi-directional data bus that connects to an 8-bit standard MPU data bus.
19	D1	
20	D2	When the serial interface is selected, then D0 serves as the serial clock input pad (SCL) and D1 serves as the serial data input pad (SI). At this time, D2 to D7 are set to high impedance.
21	D3	
22	D4	When the I ² C interface is selected, then D0 serves as the serial clock input pad (SCL) and D1 serves as the serial data input pad (SDAI). At this time, D2 to D7 are set to high impedance.
23	D5	
24	D6	
25	D7	
26	IREF	
27	VCOMH	COM signal deselected voltage level. A capacitor should be connected between this pin and VSS.
28	VCC	Power supply for panel driving voltage.
29	NC	No connection.
30	N.C.(GND)	Reserved pin. It should be connected to VSS.



8.5 INTERFACE TIMING CHART

(1) System buses Read/Write characteristics 1 (For the 8080 Series Interface MPU)

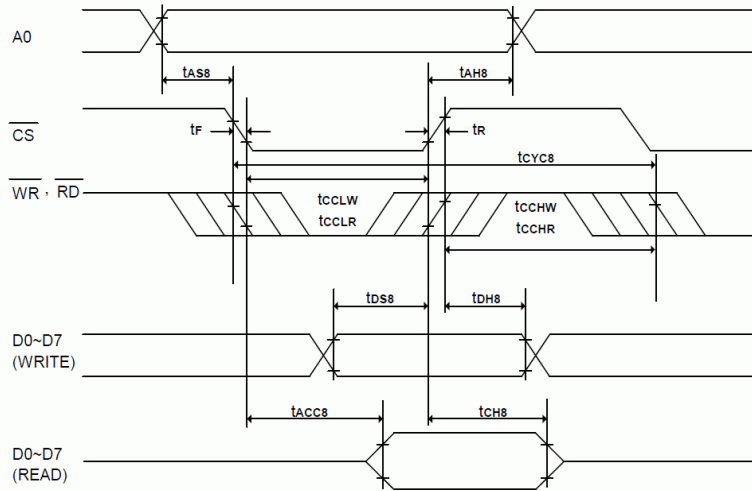

(VDD1 = 1.65 - 3.5V, TA = +25°C)

Symbol	Parameter	Min.	Typ.	Max.	Unit	Condition
tcyc8	System cycle time	600	-	-	ns	
tAS8	Address setup time	0	-	-	ns	
tAH8	Address hold time	0	-	-	ns	
tDS8	Data setup time	80	-	-	ns	
tDH8	Data hold time	30	-	-	ns	
tCH8	Output disable time	20	-	140	ns	CL = 100pF
tACC8	\overline{RD} access time	-	-	280	ns	CL = 100pF
tcCLW	Control L pulse width (WR)	200	-	-	ns	
tcCLR	Control L pulse width (RD)	240	-	-	ns	
tcCHW	Control H pulse width (WR)	200	-	-	ns	
tcCHR	Control H pulse width (RD)	200	-	-	ns	
tr	Rise time	-	-	30	ns	
tf	Fall time	-	-	30	ns	

(VDD1 = 2.4 - 3.5V, TA = +25°C)

Symbol	Parameter	Min.	Typ.	Max.	Unit	Condition
tcyc8	System cycle time	300	-	-	ns	
tAS8	Address setup time	0	-	-	ns	
tAH8	Address hold time	0	-	-	ns	
tDS8	Data setup time	40	-	-	ns	
tDH8	Data hold time	15	-	-	ns	
tCH8	Output disable time	10	-	70	ns	CL = 100pF
tACC8	\overline{RD} access time	-	-	140	ns	CL = 100pF
tcCLW	Control L pulse width (WR)	100	-	-	ns	
tcCLR	Control L pulse width (RD)	120	-	-	ns	
tcCHW	Control H pulse width (WR)	100	-	-	ns	
tcCHR	Control H pulse width (RD)	100	-	-	ns	
tr	Rise time	-	-	15	ns	
tf	Fall time	-	-	15	ns	

9. POWER ON / OFF SEQUENCE & APPLICATION CIRCUIT

9.1 POWER ON / OFF SEQUENCE

Built-in DC-DC pump power is being used immediately after turning on the power:

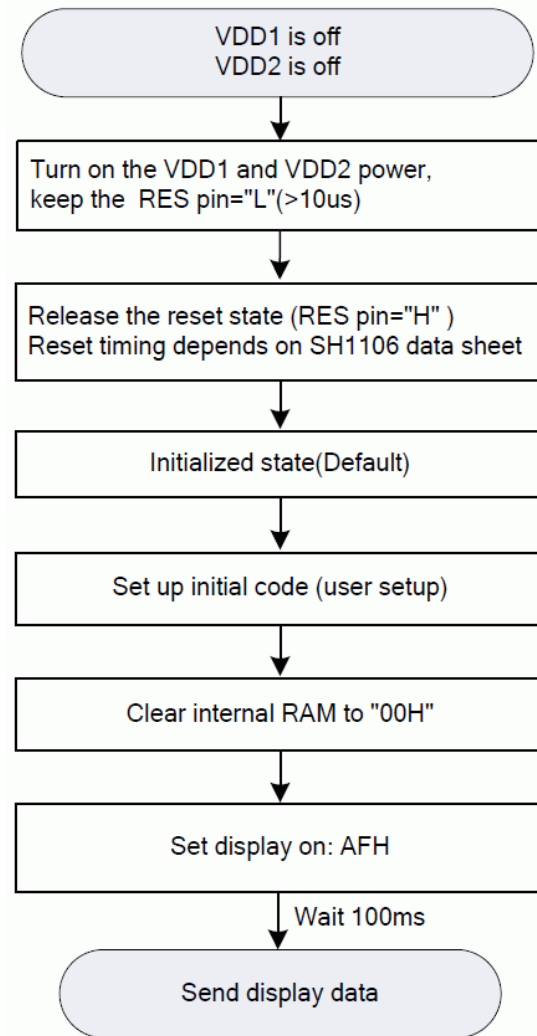

Power on sequence:

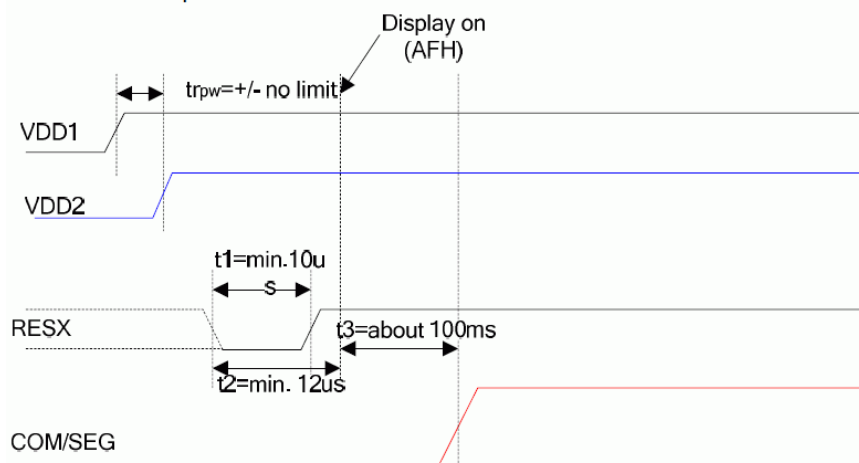

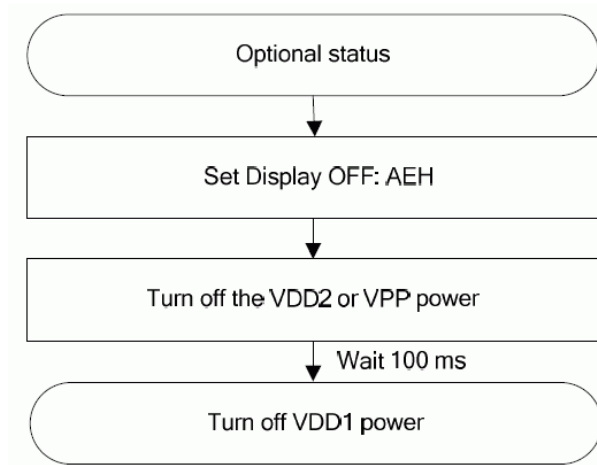

Power off sequence:

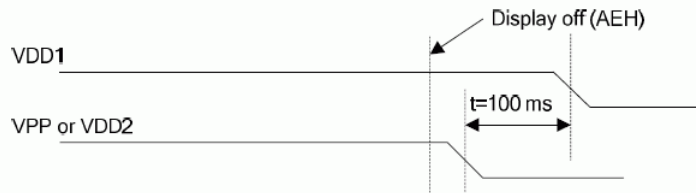

Note: There will be no damages to the display module if the power sequences are not met.

9.2 APPLICATION CIRCUIT

(Charge Pump)

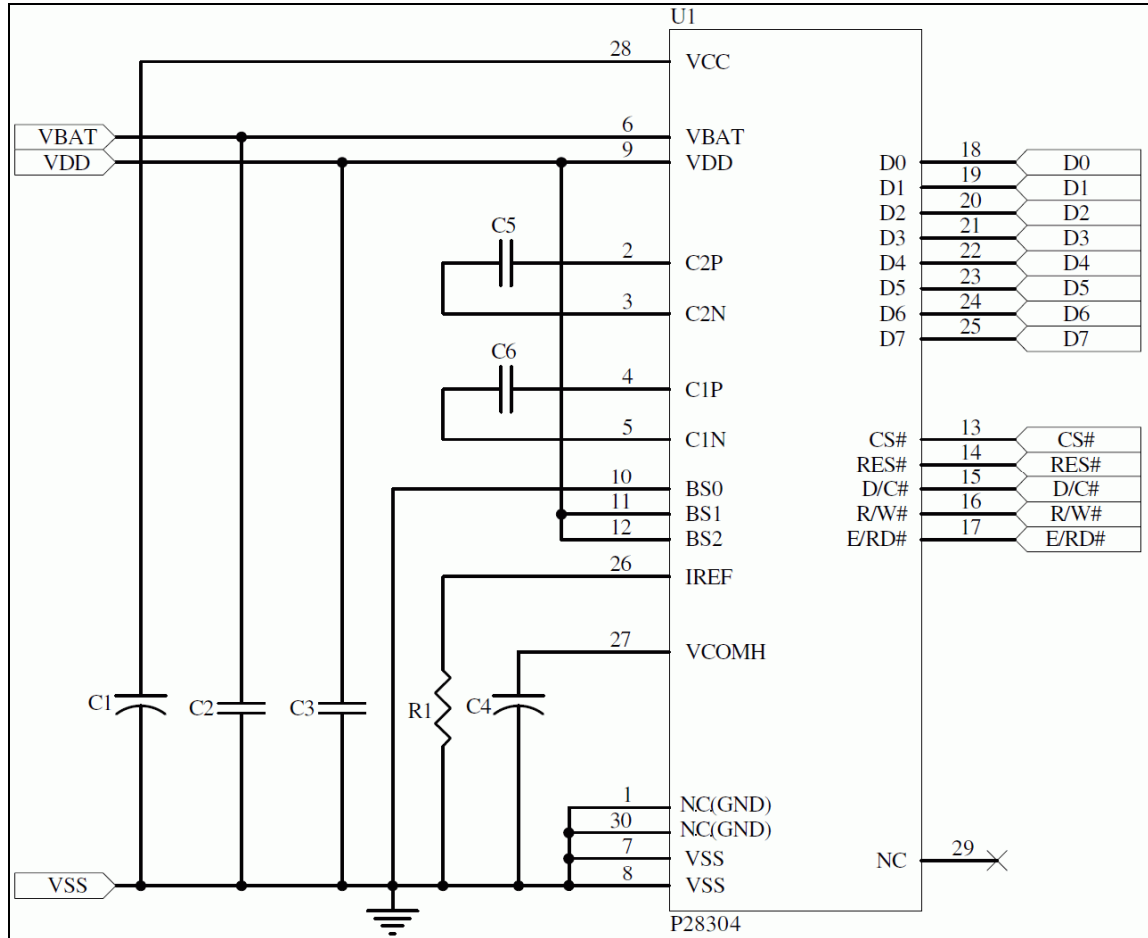

Recommend components:

C1: 2.2uF/16V(0805)

C2, C3, C5, C6: 1uF/16V(0603)

C4: 4.7uF/25V (Tantalum type) or VISHAY (572D475X0025A2T)

R1: 620K ohm (0603) 1%

This circuit is for 8080 8bits interface.

9.3 COMMAND TABLE

Refer to SH1106G IC Spec.



10. RELIABILITY TEST CONDITIONS

No.	Items	Specification	Quantity
1	High temp. (Non-operation)	85 °C, 240hrs	5
2	High temp. (Operation)	70 °C, 120hrs	5
3	Low temp. (Operation)	-40 °C, 120hrs	5
4	High temp. / High humidity (Operation)	65 °C, 90%RH, 120hrs	5
5	Thermal shock (Non-operation)	-40 °C ~85 °C (-40 °C /30min; transit /3min; 85 °C /30min; transit /3min) 1cycle: 66min, 100 cycles	5
6	Vibration	Frequency : 5~50HZ, 0.5G Scan rate : 1 oct/min Time : 2 hrs/axis Test axis : X, Y, Z	1 Carton
7	Drop	Height: 120cm Sequence : 1 angle 、3 edges and 6 faces Cycles: 1	1 Carton
8	ESD (Non-operation)	Air discharge model, ±8kV, 10 times	5

Test and measurement conditions

1. All measurements shall not be started until the specimens attain to temperature stability.
2. The degradation of Polarizer are ignored for item 1, 4 & 5.

Evaluation criteria

1. The function test is OK.
2. No observable defects.
3. Luminance: > 50% of initial value.
4. Current consumption: within \pm 50% of initial value.



11. EXTERNAL DIMENSION

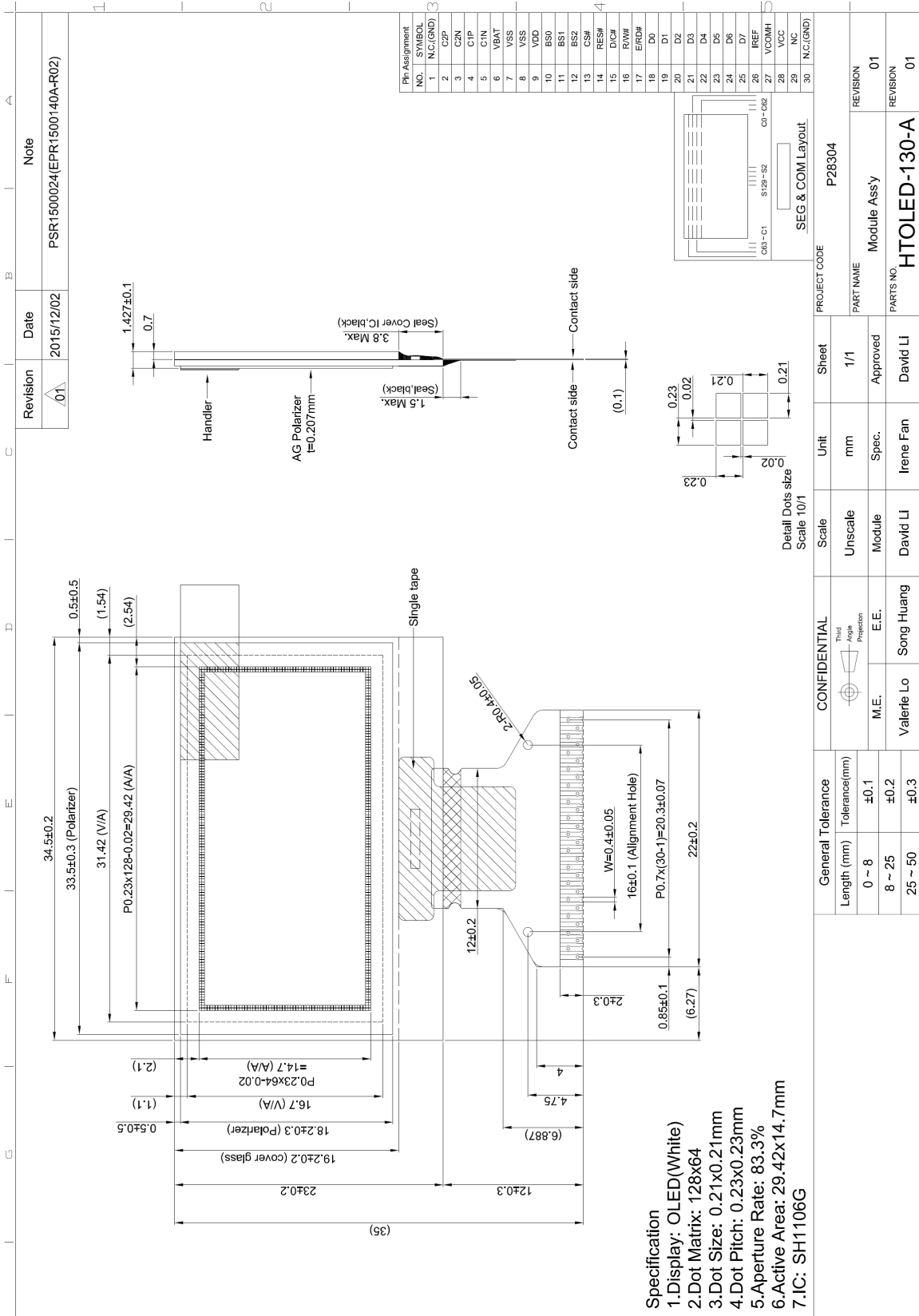

12. PACKING SPECIFICATION

Revision	Date	Note	
01	2015/12/15	Packing Tray Instruction	

1 Face Up x 36 pcs

2 80L9828304000 Module Ass'y For P28304

3 7003010000001 5G 干燥剂 x4 pcs

4 Vacuum Bag ONY/LDPE 真空包装袋 480x285x90

5 Antistatic Bubble bag 440x(350+450)mm 抗静电气泡袋

6 Pizza Box 345x285x88,B corrugated

7 Carton 385x305x203mm

8 Label x1 pcs

9 Tape =21 pcs

Tray =20 pcs

rotate stack 旋轉堆疊

Label x2 pcs

Label x2 pcs

ITEM	PART No.	DESC	QTY
	90L9928304000		
1	80L9828304000	Module Ass'y For 28304	1440
2	700P320011001	Tray 330x270x10.7 T10.7mm PS P28304	42
3	7003010000001	5G Silica Gel Desiccants 透明	8
4		Vacuum Bag ONY/LDPE 480x285x90	2
5		Antistatic Bubble bag 440x(350+450)mm	2
6		Pizza Box 345x285x88,B corrugated	2
7		Carton 385x305x203mm	1
8		Label	3
9		Tape, W=48mm, L=910cm	

General Tolerance		CONFIDENTIAL		PROJECT CODE	
Length (mm)	Tolerance(mm)	Sheet	Scale	Unit	Sheet
0 ~ 8	±0.1	1/1	1:15	mm	P28304
8 ~ 25	±0.2	M.E.	Module	Spec.	PART NAME
25 ~ 50	±0.3	Valerie Lo	x	Irene Fan	Packing Tray Instruction
					VERSION
					01
					PARTS NO.
					HTOLED-130-A
					VERSION
					01



13. OUTGOING INSPECTION PROVISION

1. 抽樣方法 / SAMPLING METHOD

- (1) MIL-STD-1916 / 驗證水準 level III / 正常檢驗 / 單次樣品檢驗
MIL-STD-1916 / inspection level III / normal inspection / single sample inspection
- (2) 主要缺陷 Level III ; 次要缺陷 Level II
Major Level III ; Minor Level II

MIL-STD-1916 樣本代字對照表							
批量	驗證水準 (VL)						
	VII	VI	V	IV	III	II	I
2 ~ 170	A	A	A	A	A	A	A
171 ~ 288	A	A	A	A	A	A	B
289 ~ 544	A	A	A	A	A	B	C
545 ~ 960	A	A	A	A	B	C	D
961 ~ 1632	A	A	A	B	C	D	E
1633 ~ 3072	A	A	B	C	D	E	E
3073 ~ 5440	A	B	C	D	E	E	E
5441 ~ 9216	B	C	D	E	E	E	E
9217 ~ 17408	C	D	E	E	E	E	E
17409 ~ 30720	D	E	E	E	E	E	E
≥ 30721	E	E	E	E	E	E	E

2. 檢驗條件 / INSPECTION CONDITION

檢查和測量在下列條件下進行的，除非另有規定。

The inspection and measurement are performed under the following conditions, unless otherwise specified.

溫度 / Temperature: 25±5 °C

濕度 / Humidity: 50±10%R.H.

壓力 / Pressure: 860~1060hPa (mbar)

檢驗員拿的面板和眼睛之間的距離 / Distance between the panel and eyes of the inspector ≥ 30cm



3. 品質檢驗規格 / SPECIFICATION FOR QUALITY CHECK

3.1 缺陷分類 / DEFECT CLASSIFICATION

嚴重度 Severity	檢驗項目 Inspection Item	缺陷 Defect	備註 Remark
主要缺陷 Major Defect	1. 面板 Panel	(1) 無顯示 Non-displaying	
		(2) 線缺陷 Line defects	
		(3) 故障 Malfunction	
		(4) 玻璃破損 Glass cracked	
	2. 軟板 Film	(1) 軟板尺寸超規 Film dimension out of specification	不能組裝 Can not be assembled
	3. 尺寸 Dimension	(1) 外形尺寸超規 Outline dimension out of specification	
次要缺陷 Minor Defect	1. 面板 Panel	(1) 玻璃刮傷 Glass scratch	外觀缺陷 Appearance defect
		(2) 玻璃切割異常 Glass cutting NG	
		(3) 玻璃崩邊、崩角 Glass chip	
	2. 偏光板 Polarizer	(1) 偏光板刮傷 Polarizer scratch	
		(2) 表面汙漬 Stains on surface	
		(3) 偏光板氣泡 Polarizer bubbles	
	3. 顯示 Displaying	(1) 暗點、亮點、髒污 Dim spot·Bright spot·dust	
	4. 軟板 Film	(1) 損傷 Damage	
		(2) 異物 Foreign material	

3.2 出貨規格 / OUTGOING SPECIFICATION

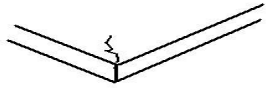
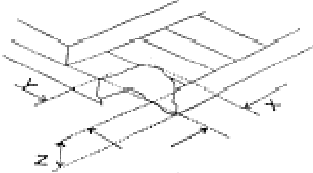
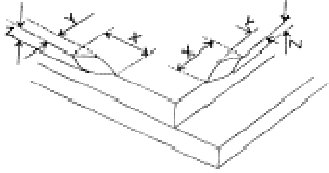
項目 Item	描述 Description	標準 Criterion	允收 水準 AQL															
I. 面板 Panel	1. 玻璃刮傷 Glass scratch	<table border="1" style="width: 100%; border-collapse: collapse; text-align: center;"> <thead> <tr> <th style="width: 33%;">寬 / Width (mm) W</th> <th style="width: 33%;">長 / Length (mm) L</th> <th style="width: 33%;">容許個數 number of pieces permitted</th> </tr> </thead> <tbody> <tr> <td>$W \leq 0.03$</td> <td>忽略 Ignore</td> <td>忽略 Ignore</td> </tr> <tr> <td>$0.03 < W \leq 0.05$</td> <td>$L \leq 1$</td> <td>1</td> </tr> <tr> <td>$0.05 < W$</td> <td>-----</td> <td>無 None</td> </tr> <tr> <td>顯示區外 beyond A.A.</td> <td>-----</td> <td>忽略 Ignore</td> </tr> </tbody> </table>	寬 / Width (mm) W	長 / Length (mm) L	容許個數 number of pieces permitted	$W \leq 0.03$	忽略 Ignore	忽略 Ignore	$0.03 < W \leq 0.05$	$L \leq 1$	1	$0.05 < W$	-----	無 None	顯示區外 beyond A.A.	-----	忽略 Ignore	次要 Minor
	寬 / Width (mm) W	長 / Length (mm) L	容許個數 number of pieces permitted															
	$W \leq 0.03$	忽略 Ignore	忽略 Ignore															
$0.03 < W \leq 0.05$	$L \leq 1$	1																
$0.05 < W$	-----	無 None																
顯示區外 beyond A.A.	-----	忽略 Ignore																
2. 玻璃破損 Glass crack	<p>(1) 裂紋 / Crack 擴展裂紋是不能接受的。 Propagation crack is not acceptable.</p> 	主要 Major																
3. 玻璃崩邊、崩角 Glass chip	<p>(1) 崩角 / Chip on corner</p>  <p>(2) 崩邊 / Chip on edge</p> 	次要 Minor																



項目 Item	描述 Description	標準 Criterion	允收 水準 AQL																
I. 面板 Panel	3. 玻璃崩邊、崩角 Glass chip	<table border="1" style="width: 100%; border-collapse: collapse; margin-bottom: 10px;"> <thead> <tr> <th style="text-align: center;">崩角 Chip on corner</th> <th style="text-align: center;">Size (mm)</th> <th style="text-align: center;">崩邊 Chip on edge</th> <th style="text-align: center;">Size (mm)</th> </tr> </thead> <tbody> <tr> <td style="text-align: center;">X</td> <td style="text-align: center;">≤ 1.5</td> <td style="text-align: center;">X</td> <td style="text-align: center;">≤ 3.0</td> </tr> <tr> <td style="text-align: center;">Y</td> <td style="text-align: center;">≤ 2.0</td> <td style="text-align: center;">Y</td> <td style="text-align: center;">≤ 1.0</td> </tr> <tr> <td style="text-align: center;">Z</td> <td style="text-align: center;">$\leq t$</td> <td style="text-align: center;">Z</td> <td style="text-align: center;">$\leq t$</td> </tr> </tbody> </table> <p>備註 / Note: 1. t = 玻璃厚度 t = glass thickness 2. 崩邊或崩角延伸到 ITO 導線是不能接受的。 Chip on the corner extending into the ITO contact is not acceptable.</p>	崩角 Chip on corner	Size (mm)	崩邊 Chip on edge	Size (mm)	X	≤ 1.5	X	≤ 3.0	Y	≤ 2.0	Y	≤ 1.0	Z	$\leq t$	Z	$\leq t$	次要 Minor
	崩角 Chip on corner	Size (mm)	崩邊 Chip on edge	Size (mm)															
X	≤ 1.5	X	≤ 3.0																
Y	≤ 2.0	Y	≤ 1.0																
Z	$\leq t$	Z	$\leq t$																
	4. 尺寸 Dimension	請參閱圖紙的規範。 Refer to the drawing of the spec	主要 Major																
II. 偏光板 Polarizer	1. 刮傷 Scratch	點狀按照“項目 II-3 偏光板氣泡”的標準。 Spot type in accordance with the criteria of “Item II-3. Polarizer bubble”. 線狀按照“項目 I-1 玻璃刮傷”的標準。 Line type in accordance with the criteria of “Item I-1. Glass scratch”.	次要 Minor																
	2. 表面汗漬 Stains on surface	表面汗漬無法用軟布或類似的清潔物輕輕擦拭 去除。 Stains cannot be removed even when wiped lightly with a soft cloth or similar cleaning.	次要 Minor																
	3. 偏光板氣泡 Polarizer bubble	<table border="1" style="width: 100%; border-collapse: collapse; margin-bottom: 10px;"> <thead> <tr> <th style="text-align: center;">尺寸 Size</th> <th style="text-align: center;">容許個數 number of pieces permitted</th> </tr> </thead> <tbody> <tr> <td style="text-align: center;">$\Phi \leq 0.2$</td> <td style="text-align: center;">忽略 Ignore</td> </tr> <tr> <td style="text-align: center;">$0.2 < \Phi \leq 0.5$</td> <td style="text-align: center;">2</td> </tr> <tr> <td style="text-align: center;">$0.5 < \Phi$</td> <td style="text-align: center;">0</td> </tr> <tr> <td style="text-align: center;">顯示區外 beyond A.A.</td> <td style="text-align: center;">忽略 Ignore</td> </tr> </tbody> </table>	尺寸 Size	容許個數 number of pieces permitted	$\Phi \leq 0.2$	忽略 Ignore	$0.2 < \Phi \leq 0.5$	2	$0.5 < \Phi$	0	顯示區外 beyond A.A.	忽略 Ignore	次要 Minor						
尺寸 Size	容許個數 number of pieces permitted																		
$\Phi \leq 0.2$	忽略 Ignore																		
$0.2 < \Phi \leq 0.5$	2																		
$0.5 < \Phi$	0																		
顯示區外 beyond A.A.	忽略 Ignore																		



項目 Item	描述 Description	標準 Criterion	允收 水準 AQL											
III. 顯示 Displaying	1. 耗電 Power consumption	該模組的工作電流消耗不應超出產品規格書的規範。 The module operating current consumption should not go beyond the standard indicated in Product Specification	主要 Major											
	2. 像素尺寸 Pixel size	顯示像素的尺寸的公差應規格的±25%之內。 The tolerance of display pixel dimension should be within ±25% of specification.	次要 Minor											
	3. 顏色 Color	依據產品規格。 Refer to the product specification.	主要 Major											
	4. 亮度 Luminance	依據產品規格。 Refer to the product specification.	主要 Major											
	5. 暗點、亮點、 髒污 Dimming spot、Lighting spot、Dust	1. <table border="1" style="margin-left: 20px;"> <thead> <tr> <th>平均直徑 Average diameter D:(mm)</th> <th>容許個數 number of pieces permitted</th> </tr> </thead> <tbody> <tr> <td>$D \leq 0.1$</td> <td>忽略 Ignore</td> </tr> <tr> <td>$0.1 < D \leq 0.15$</td> <td>1</td> </tr> <tr> <td>$0.15 < D \leq 0.2$</td> <td>1</td> </tr> <tr> <td>$0.2 < D$</td> <td>0</td> </tr> <tr> <td>顯示區外 beyond A.A.</td> <td>忽略 Ignore</td> </tr> </tbody> </table> <p>D=(長邊直徑 + 短邊直徑)/2 D=(long diameter + short diameter)/2 像素暗點是不允許。 Pixel off is not allowed.</p>	平均直徑 Average diameter D:(mm)	容許個數 number of pieces permitted	$D \leq 0.1$	忽略 Ignore	$0.1 < D \leq 0.15$	1	$0.15 < D \leq 0.2$	1	$0.2 < D$	0	顯示區外 beyond A.A.	忽略 Ignore
平均直徑 Average diameter D:(mm)	容許個數 number of pieces permitted													
$D \leq 0.1$	忽略 Ignore													
$0.1 < D \leq 0.15$	1													
$0.15 < D \leq 0.2$	1													
$0.2 < D$	0													
顯示區外 beyond A.A.	忽略 Ignore													



項目 Item	描述 Description	標準 Criterion	允收 水準 AQL															
III. 顯示 Displaying	5. 暗點、亮點、 髒污 Dimming spot、Lighting spot、Dust	2.	次要 Minor															
		<table border="1" style="width: 100%; border-collapse: collapse;"> <thead> <tr> <th style="text-align: center;">寬 width(mm) W</th> <th style="text-align: center;">長 length(mm) L</th> <th style="text-align: center;">容許個數 number of pieces permitted</th> </tr> </thead> <tbody> <tr> <td style="text-align: center;">$W \leq 0.03$</td> <td style="text-align: center;">忽略 Ignore</td> <td style="text-align: center;">忽略 Ignore</td> </tr> <tr> <td style="text-align: center;">$0.03 < W \leq 0.05$</td> <td style="text-align: center;">$L \leq 1$</td> <td style="text-align: center;">3</td> </tr> <tr> <td style="text-align: center;">$0.05 < W$</td> <td style="text-align: center;">-----</td> <td style="text-align: center;">無 None</td> </tr> <tr> <td style="text-align: center;">顯示區外 beyond A.A.</td> <td style="text-align: center;">-----</td> <td style="text-align: center;">忽略 Ignore</td> </tr> </tbody> </table>		寬 width(mm) W	長 length(mm) L	容許個數 number of pieces permitted	$W \leq 0.03$	忽略 Ignore	忽略 Ignore	$0.03 < W \leq 0.05$	$L \leq 1$	3	$0.05 < W$	-----	無 None	顯示區外 beyond A.A.	-----	忽略 Ignore
		寬 width(mm) W		長 length(mm) L	容許個數 number of pieces permitted													
		$W \leq 0.03$		忽略 Ignore	忽略 Ignore													
		$0.03 < W \leq 0.05$		$L \leq 1$	3													
$0.05 < W$	-----	無 None																
顯示區外 beyond A.A.	-----	忽略 Ignore																
IV. 軟板 Film	1. 尺寸 Dimension	軟板尺寸超規。 Film dimension out of Spec.	主要 Major															
	2. 損傷 Damage	破損；深刮傷；深摺痕；深壓痕或其他損害是不能接受的。 Crack; deep scratch; deep fold; deep pressure mark or other damage is not acceptable.	次要 Minor															
	3. 異物 Foreign material	導電異物附著在導線，軟板和玻璃之間的異物是不能接受的。 Conductive foreign material sticking to the leads, foreign material between film and glass are not acceptable.	次要 Minor															

14. APPENDIXES

APPENDIX 1: DEFINITIONS

A. DEFINITION OF CHROMATICITY COORDINATE

The chromaticity coordinate is defined as the coordinate value on the CIE 1931 color chart for R, G, B, W.

B. DEFINITION OF CONTRAST RATIO

The contrast ratio is defined as the following formula:

$$\text{Contrast Ratio} = \frac{\text{Luminance of all pixels on measurement}}{\text{Luminance of all pixels off measurement}}$$

C. DEFINITION OF RESPONSE TIME

The definition of turn-on response time T_r is the time interval between a pixel reaching 10% of steady state luminance and 90% of steady state luminance. The definition of turn-off response time T_f is the time interval between a pixel reaching 90% of steady state luminance and 10% of steady state luminance. It is shown in Figure 2.

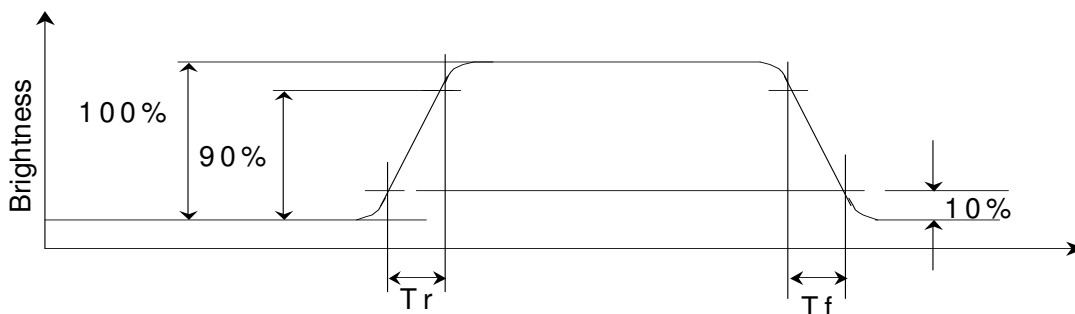

Figure 2: Response time

D. DEFINITION OF VIEWING ANGLE

The viewing angle is defined as Figure 3. Horizontal and vertical (H & V) angles are determined for viewing directions where luminance varies by 50% of the perpendicular value.

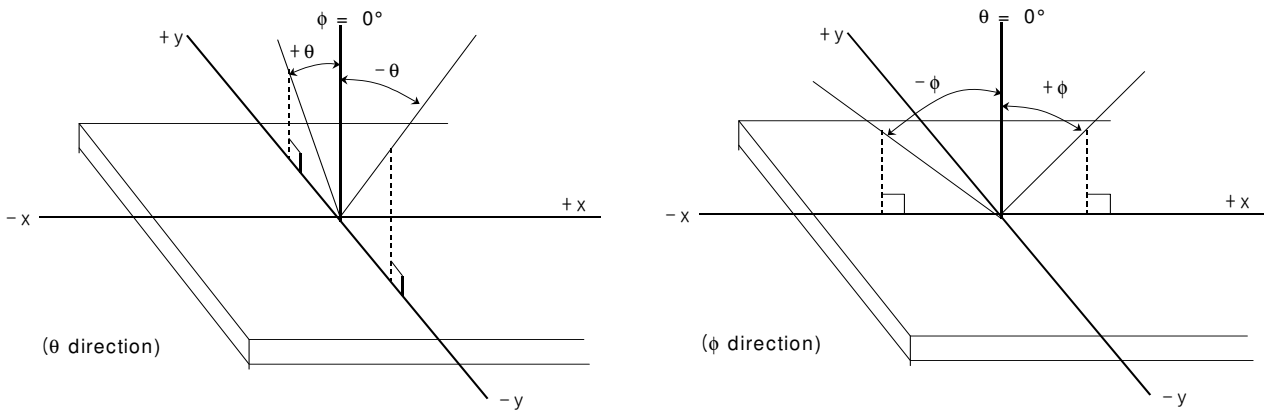
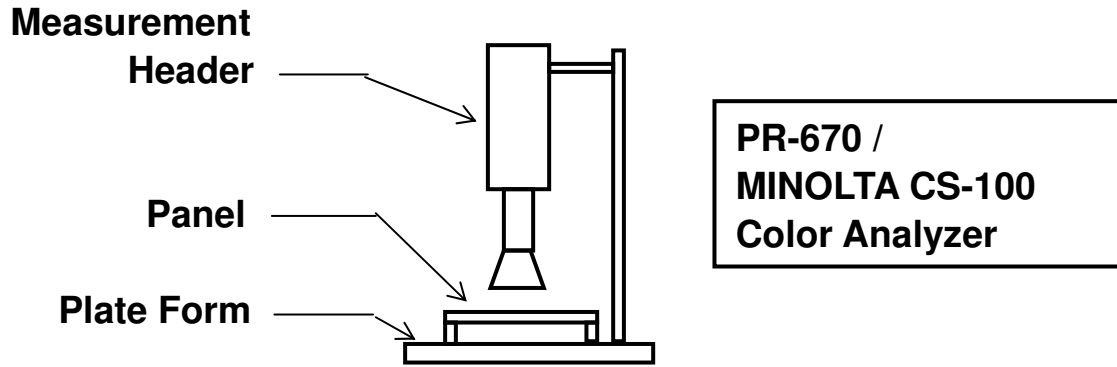

Figure 3: Viewing Angle

APPENDIX 2: MEASUREMENT APPARATUS

A. LUMINANCE/COLOR COORDINATE

PHOTO RESEARCH PR-670, MINOLTA CS-100



B. CONTRAST / RESPONSE TIME / VIEW ANGLE

WESTAR CORPORATION FPM-510

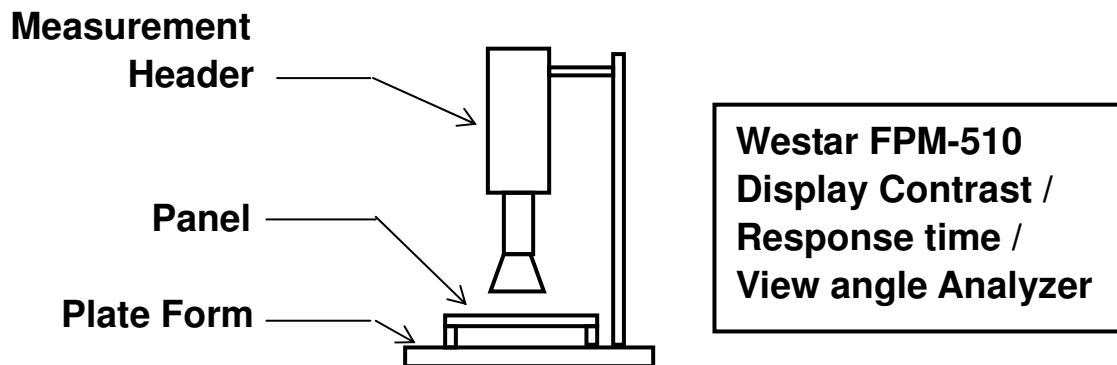



C. ESD ON AIR DISCHARGE MODE

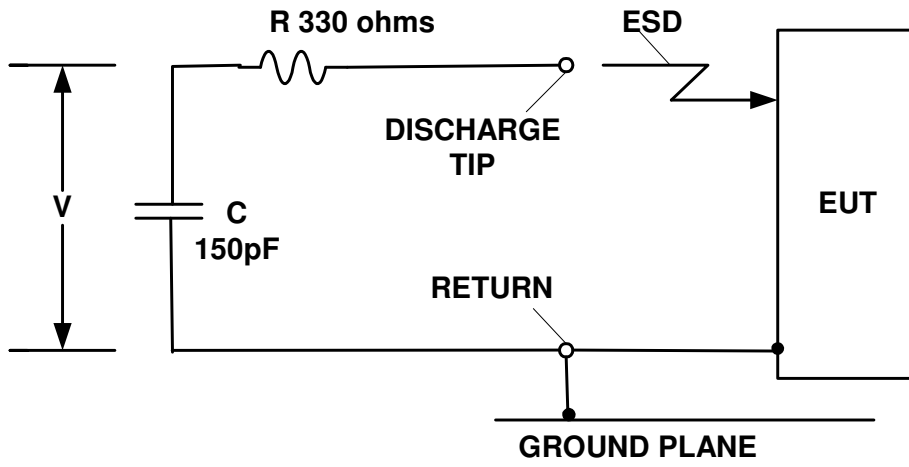

APPENDIX 3: PRECAUTIONS FOR USING THE OLED MODULE

Precautions for Handling

1. When handling the module, wear powder-free anti static rubber finger cots/ anti-static clothing, anti-static gloves ,antistatic wrist strap and anti-static shoes

The environment should dispose the static elimination blower, anti-static pad, anti-static chair, and anti-static floor. The humidity maintains usually more than 40%



2. The OLED module is an electronic component and is subject to damage caused by Electro Static Discharge (ESD). And hence normal ESD precautions must be taken when handling it. Also, appropriate ESD protective environment must be administered and maintained in the production line. When handling and assembling the panel, wear an antistatic wrist strap with the alligator clip attached to the ground to prevent ESD damage on the panel. Antistatic wrist strap should touch human body directly instead of gloves. (See below photos).

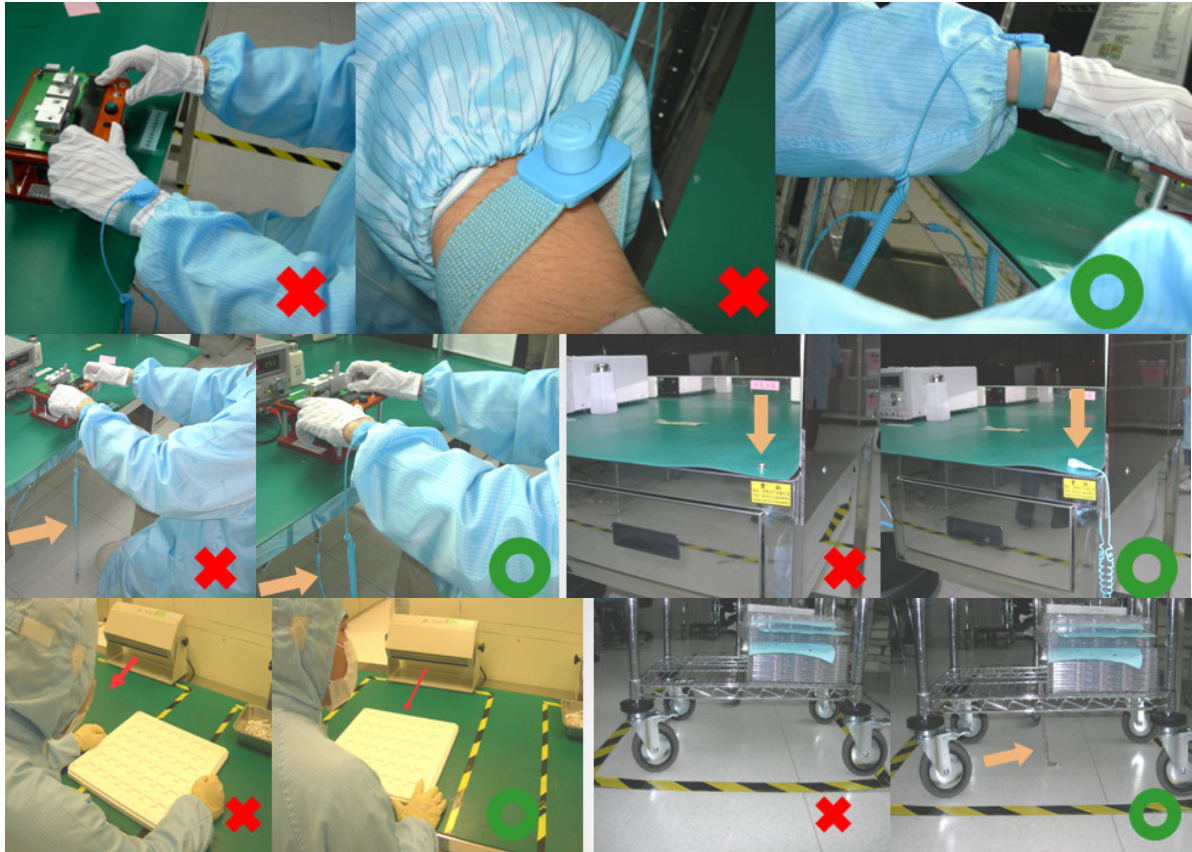

3. The OLED module is consisted of glass and film, and it should avoid pressure, strong impact, or being dropped from a high position.

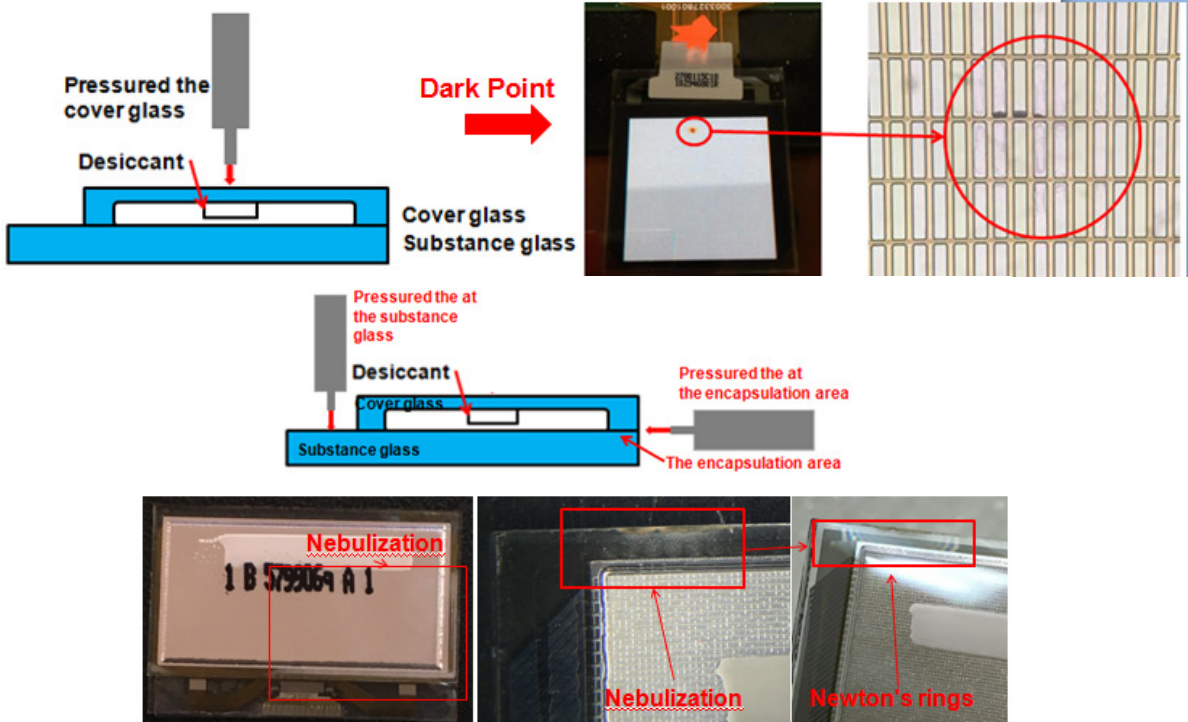

4. Take out the panel one by one from the holding trays for assembly, and never put the panel on top of another one to avoid the scratch.

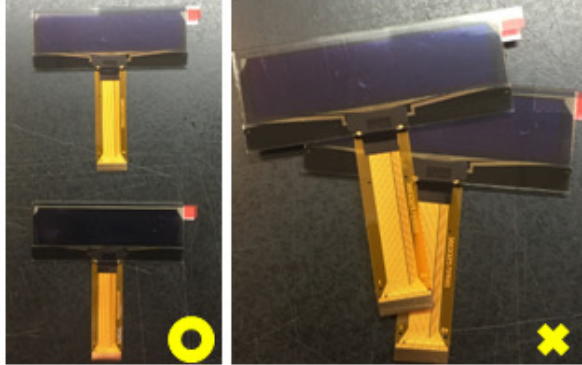

5. Avoid jerk and excessive bend on TAB/FPC/COF, and be careful not to let foreign matter or bezel damage the film.

6. When handling and assembling the module (panel + IC), grab the panel, not the TAB/FPC/COF.

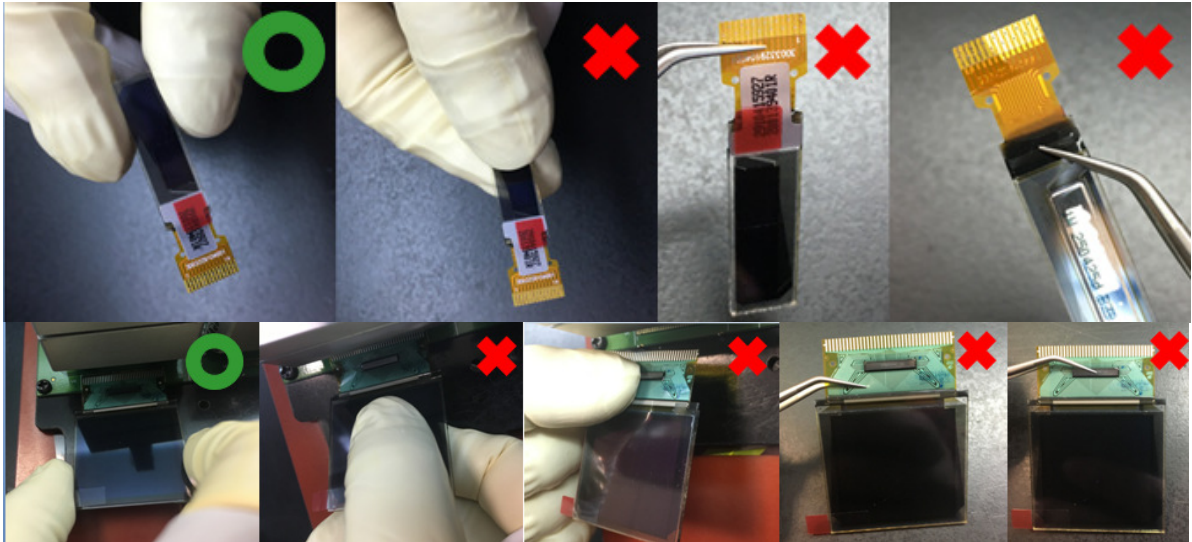

7. Use the tweezers to open the clicks on the connector of PCB before the insertion of FPC/COF, and click them back in. Once the FPC/COF sits properly in the connector, use the tweezers to avoid the damages.



8. Please do not bend the film near the substrate glass. It could cause film peeling and TAB/FPC/COF damage. For TAB, It should bend the slit area as actual OLED it is. For FPC or COF, it is suggested to follow below pictures for instruction (distance between substrate glass and bending area $>1.5\text{mm}$; $R>0.5\text{mm}$).

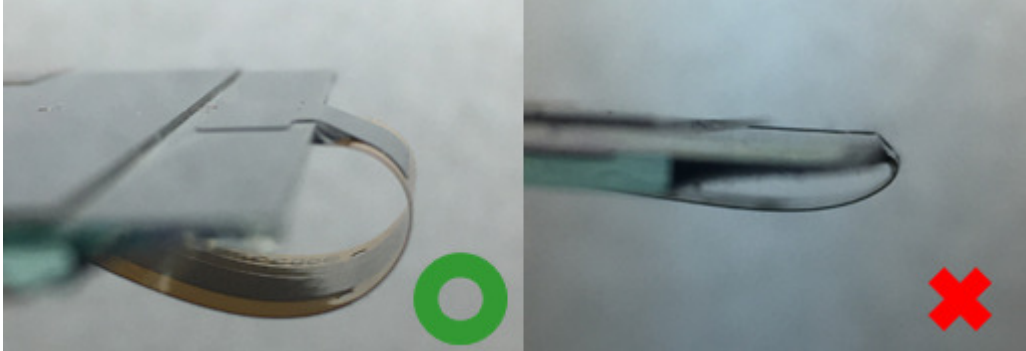

9. Avoid bending the film at IC bonding area. It could damage the IC ILB bonding. It should avoid bending the IC seal area. Please keep the bending distance $>1.5\text{mm}$.

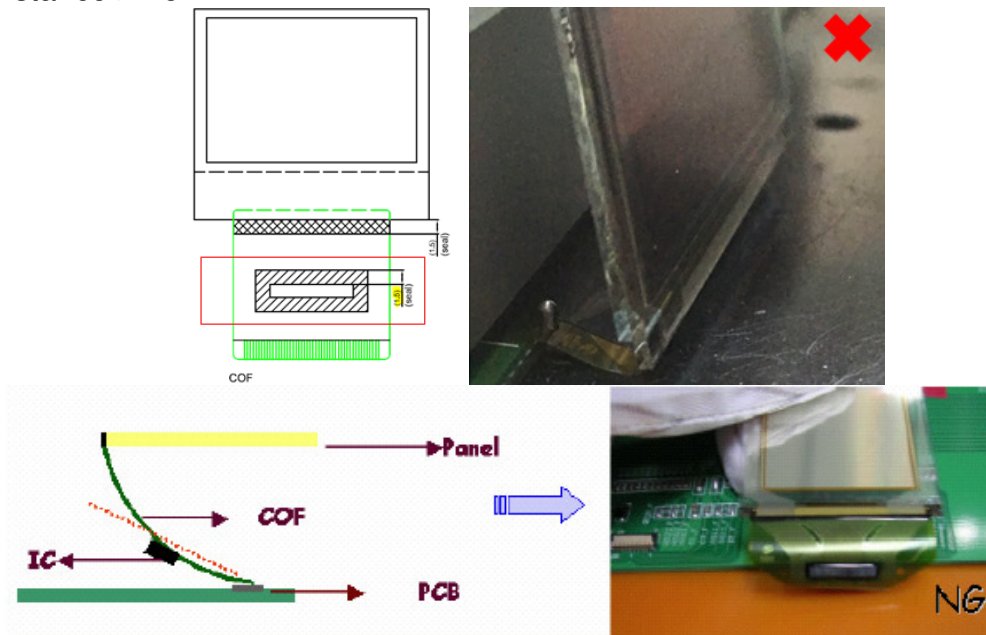

Use finger to insert COF /FPC into the connector when assembling the panel.
Please refer to the photo.

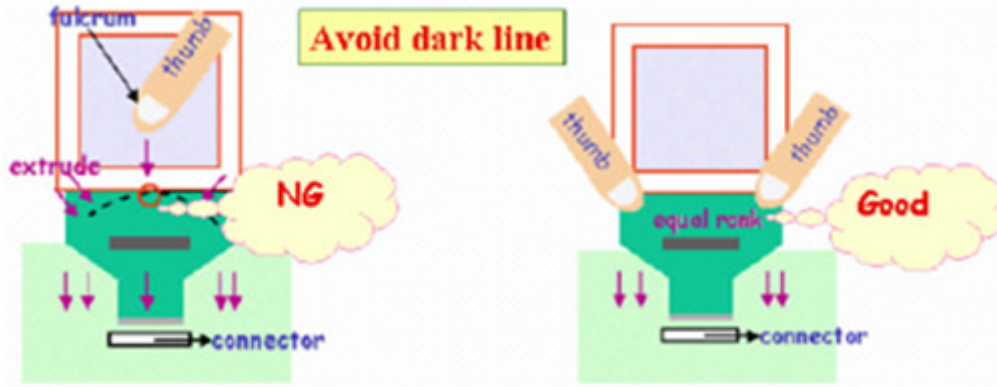

COF: Use both thumbs

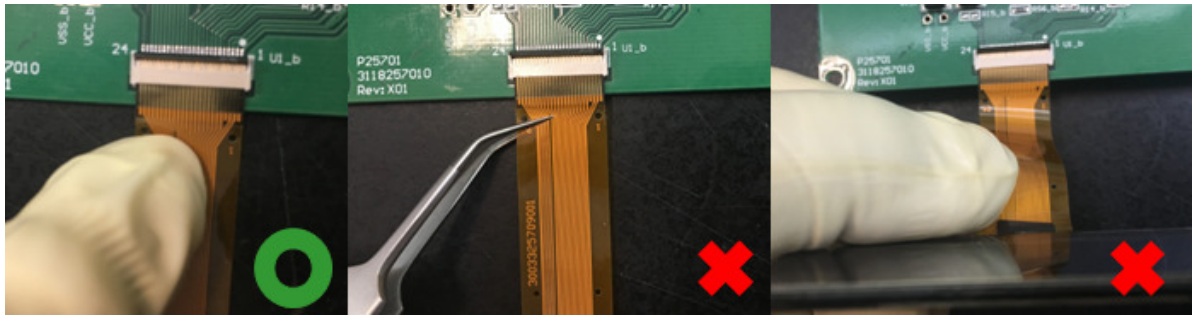

10. Do not wipe the pin of film and polarizer with the dry or hard materials that will damage the surface. When cleaning the display surface, use the soft cloth with solvent, IPA or alcohol, to clean.

11. Protection film is applied to the surface of OLED panel to avoid the scratch. Please remove the protective film before assembling it. If the OLED panel has been stored for a long time, the residue adhesive material of the protective film may remain on the display surface after remove the protective film. Please use the soft cloth with solvent, IPA or alcohol, to clean.

12. When hand or hot-bar soldering TAB/FPC onto PCB, make sure the temperature and timing profiles to meet the requirements of soldering specification (the specification depends on the application or optimized by customer) to prevent the damage of IC pins by inappropriate soldering, and also avoid the high temperature to damage the Organic light-emitting materials.

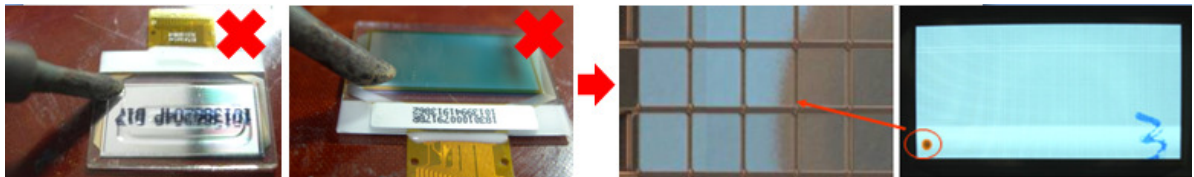

13. Solder residues arise from soldering process have to be cleaned up thoroughly before the module assembly.

14. Use the voltage and current settings listed in the specification to do the function test after the module assembly.

15. Suggestion for soldering process:

i. TAB Lead- free soldering hot bar process

1. Use pulse heated bonding tool equipment
2. Material: Sn/Ag/Cu lead-free solder paste with typical 25um thickness on PCB pad. The TAB pin size and shape may be different, please base on the production line to adjust the thickness of PCB pad and temperature.S
3. Bonding Force:--4kg per centimeter square as the starting point.
4. Suggested bonding tool temperature & time profile is as below for reference. Since there are differences in TAB soldering pins, soldering technicians' skills, mechanism...etc., the soldering conditions must be adequately tuned.

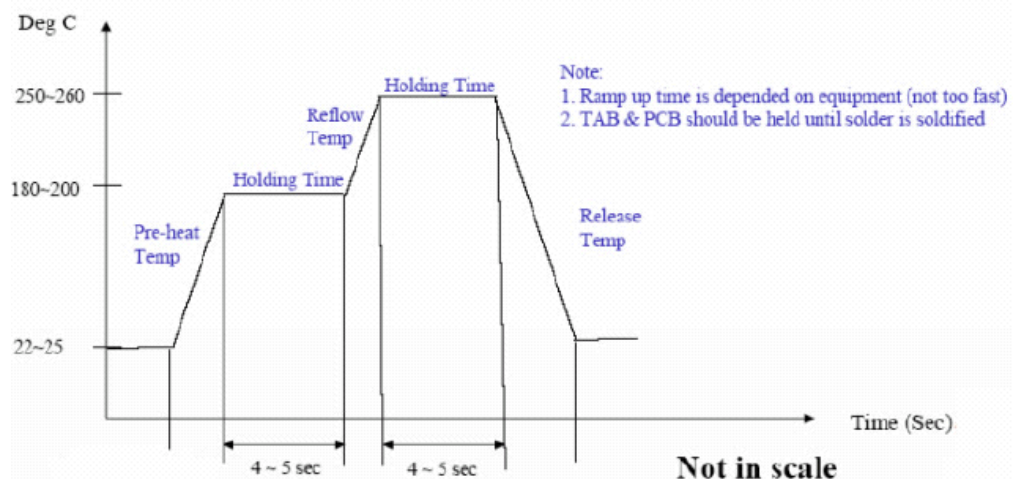

ii. TAB Lead- free soldering wire process

In case of manual soldering (Lead- free solder wire)

1. Solder wire contact iron directly: $280 \pm 5^\circ\text{C}$ at 3-5secs
2. Solder wire contact TAB lead directly (near iron but not contact): $380 \pm 5^\circ\text{C}$, 3-5secs
3. Since there are differences in TAB soldering pins, soldering technicians' skills, mechanism...etc., the soldering conditions must be adequately tuned.

iii. High temperature will result in rapid heat conduction to IC and might cause damage to IC, so please keep the temperature below 380°C . Also, avoid damaging the polyimide and solder resist which might take place at high temperatures. Refold cycles base on the de-soldering status, if the plating of pin was damaged, it can not be used again.

Precautions for Electrical

1. Residual Image (Image Sticking)

The OLED is a self-emissive device. As with other self-emissive device or displays consisting of self-emissive pixels, when a static image frozen for a long period of time is changed to another one with all-pixels-on background, residual image or image sticking is noticed by the human eye. Image sticking is due to the luminance difference or contrast between the pixels that were previously turned on and the pixels that are newly turned on. Image sticking depends on the luminance decay curve of the display. The slower the decay, the less prominent the image sticking is. It is strongly recommended that the user employ the following four strategies to minimize image sticking.

1. Employ image scrolling or animation to even out the lit-on time of each and every pixel on the display, also could use sleeping mode for reduced the residual image and extend the power capacity.
2. Minimize the use of all-pixels-on or full white background in their application because when the panel is turned on full white, the image sticking from previously shown patterns is the most revealing. Black background is the best for power savings, greatest visibility, eye appealing, and dazzling displays.
3. Avoid displaying the characters or menu with high brightness level in a fix position for a long time or repeatedly. If necessary, using the auto fadeout technology.
4. If a static logo is used in the reliability test, change the pattern into its inverse (i.e., turn off the while pixels and turn on the previously unlit pixels) and freeze the inverse pattern as long as the original logo is used, so every pixel on the panel can be lit on for about the same time to minimize image sticking, caused by the differential turn-on time between the original and its reverse patterns.

Black Background





Scrolling example

Frame1

Frame2

Frame3

Frame4

Frame5

Example: setup and start

```
comm_out2(0x26); // scrolling setup
comm_out2(0x08); // scrolling numbers/step
comm_out2(0x00); // start page
comm_out2(0x00); // scrolling step/frame
comm_out2(0x08); // end page
comm_out2(0x2F); // start
```

Example: stop

```
comm_out2(0x2E); //stop
```

Precautions for Mechanical

1. Cushion or Buffer tape on the cover glass

It is strongly recommended to have a cushion or buffer tape to apply on the panel backside and front side when assembling OLED panel into module to protect it from damage due to excessive extraneous forces.

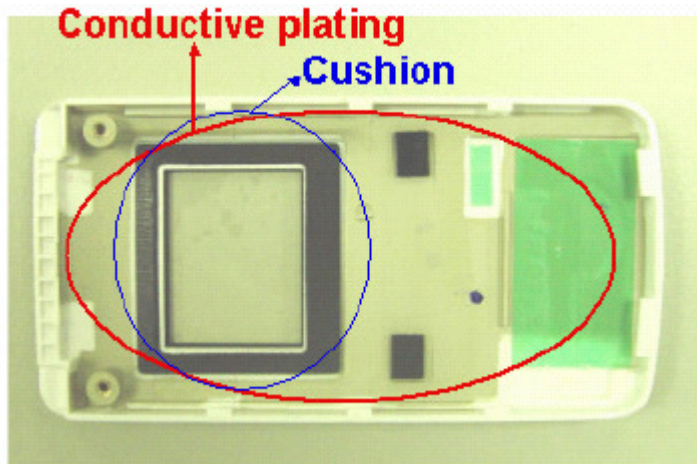

It is recommended that a plating conductive layer be used in the housing for EMI/EMC protection. And, the enough space should be reserved for the IC placement if the IC thickness is thicker than the TAB film when customer design the PCB.

2. Avoid excessive bending of film when handling or designing the panel into the product

The bending of TAB/COF/FPC has to follow the precautions indicated in the specification, extra bending or excessive extraneous forces should be avoided to minimize the chances of film damage. If bending the film is necessary, please bend the designated bending area only. Please refer to items 8 and 9 of Precautions for Handling for more information.



Precautions for Storage and Reliability Test

1. Storage

Store the packed cartons or packages at $25^{\circ}\text{C}\pm 5^{\circ}\text{C}$, $55\%\pm 10\%\text{RH}$. Do not store the OLED module under direct sunlight or UV light. For best panel performance, unpack the cartons and start the production of the panels within six months after the reception of them.

2. Reliability Test

HTdisplay only guarantees the reliability of the OLEDs under the test conditions and durations listed in the specification.