



健隆投資有限公司
STRONG BASE INVESTMENT LTD.

Unit 17, 11/F., Hewlett Centre, 52-54 Hoi Yuen Road, Kwun Tong, Kowloon, Hong Kong.
Tel: (852) 2793 3293 Fax: (852) 2793 3096



Approval Sheet
(確認書)

編號 Ref. No.	150402-01
日期 Issued Date	2015-4-02

公司名稱 : _____
Company Name

產品編號 : E1-1100CUB1
Part No.

產品種類 : 数码显示板
Category

產品描述 : 1.0 Inch、超高亮蓝光、一位、共阴、灰面白字
Description

客戶產品編號 : _____
Customer No.

備注 : _____
Remarks

STRONG BASE			
ISSUER	APPROVER	CHECKER	ENGINEER
	曾雪昭	王金龙	郭清连

Authorized Signature 客戶簽字				
部門 Department				
簽字 Signature				

工廠名稱: 宇之亮電子(深圳)有限公司
工廠地址: 廣東省深圳市龍崗區橫崗鎮荷坳村金源工業區
Company Name: Pretty Light (Shen Zhen) Limited
Factory Address: jin-Yuan, Industrial Zone He-Ao Cun, Heng-Gang
Zhen Long-Gang Area, Shen-Zhen City,
TEL: (755) 8976 7353 FAX: (755) 89767754



健隆投資有限公司

STRONG BASE INVESTMENT LTD.

Unit 17, 11/F., Hewlett Centre, 52-54 Hoi Yuen Road, Kwun Tong, Kowloon, Hong Kong.

Tel: (852) 2793 3293 Fax: (852) 2793 3096



PART No: E1-1100CUB1

Client:

Single Chip Light Electricity Characteristic Data

※Absolute Maximum Ratings at Ta=25°C

Parameter	Rating	Unit
Power Dissipation Per Chip	50	mW
Perk Forward Current Per Chip (Frequency 10KHz,1/10Duty Cycle)	60	mA
Reverse Voltage Per Chip	5	V
Operating Temperature Range	-20~+80	°C
Storage Temperature Range	-20~+85	°C
Storage Humidity	45% ~ 85%	

※Electrical and Optical Characteristics at Ta=25°C

Parameter	Symbol	Condition	Color	Min	Typ	Max	Unit
Forward Voltage Per Chip	VF	IF=20mA	Blue	2.8	3.2	3.6	v
Reverse Current	IR	VR=5V	-	-	-	50	uA
Luminous Intensity Per Chip	IV	IF=20mA	Blue	25	35	45	mcd
Dominant Wave Length	λd	IF=20mA	Blue	465	470	475	nm
Normal Forward Current	IF		All Color	5	10	20	mA

Note: Soldering Bath: not more than 4 seconds @260°C。The bottom ends of plastic reflector should be at least 2mm above the solder surface。

Soldering Iron: not more than 3 seconds @300°C under 30W。



健隆投資有限公司

STRONG BASE INVESTMENT LTD.

Unit 17, 11/F., Hewlett Centre, 52-54 Hoi Yuen Road, Kwun Tong, Kowloon, Hong Kong.

Tel: (852) 2793 3293

Fax: (852) 2793 3096



PART No.: E1-1100CUB1

Client:

PACKAGE DIMENSION(Unit: mm Tolerance: ± 0.5)

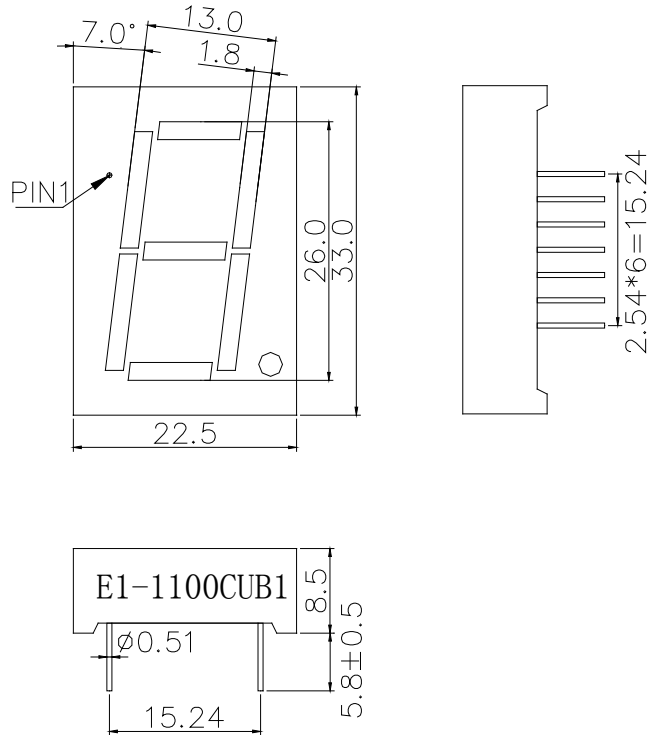

INTERNAL CIRCUIT DIAGRAM

