

XIAMEN PRECISE DISPLAY CO., LTD.

SPECIFICATIONS FOR LIQUID CRYSTAL DISPLAY

PART NUMBER:

PCM1602S-NSW-BBW-UN

DATE:

2021.06.01

1.0 MECHANICAL SPECS

1. Overall Module Size	112.0mm(W) x 44.0mm(H) x max 13.5mm(D) for LED backlight version
2. Dot Size	1.00mm(W) x 1.15mm(H)
3. Dot Pitch	1.05mm(W) x 1.20mm(H)
4. Duty	1/16
5. Controller IC	ST7066U or Equivalent
6. LC Fluid Options	STN
7. Polarizer Options	BLUE, TRANSMISSIVE, NEGATIVE
8. Viewing Angle	6:00 o'clock
9. Backlight Options	LED(White), Vbk=5.0V/60mA
10. Temperature Range Options	WideTemp (Operating: -20°C ~ 70°C, Storage: -30°C ~ 80°C)

2.0 ABSOLUTE MAXIMUM RATINGS

Item	Symbol	Min	Typ	Max	Unit
Operating temperature (Wide temperature)	Top	-20	-	70	°C
Storage temperature (Wide temperature)	Tst	-30	-	80	°C
Input voltage	Vin	Vss		Vdd	V
Supply voltage for logic	Vdd- Vss	4.5	5.0	5.5	V
Supply voltage for LCD drive	Vdd- Vo	4.2	4.5	4.7	V

3.0 ELECTRICAL CHARACTERISTICS

Item	Symbol	Condition	Min	Typ	Max	Unit
Input voltage (high)	Vih	H level	2.2	-	Vdd	V
Input voltage (low)	Vil	L level	0	-	0.6	V
Recommended LC Driving Voltage (Standard Temp)	Vdd - Vo	0°C	-	4.5	4.7	V
		25°C	4.2	4.5	-	
		50°C	4.2	4.5	-	
Recommended LC Driving Voltage (Wide Temp)	Vdd -Vo	-20°C	4.2	4.5	4.7	V
		0°C	4.2	4.5	4.7	
		50°C	4.2	4.5	4.7	
		70°C	4.2	4.5	4.7	
Power Supply Current	Idd	Vdd=5.0V, fosc=270kHz	-	0.8	1.8	mA
BackLight Power Supply Voltage	Vf	R=33Ω	-	5.0		V
BackLight Power Supply Current	If	R=33Ω	-	60	-	mA

4.0 OPTICAL CHARACTERISTICS (Ta=25°C, Vdd= 5.0V±0.25V, STN LC fluid)

Item	Symbol	Condition	Min	Typ	Max	Unit
Viewing angle (horizontal)	θ	Cr ≥ 2.0	-60	-	35	deg
Viewing angle (vertical)	φ	Cr ≥ 2.0	-40	-	40	deg
Contrast Ratio	Cr	φ=0°, θ=0°	-	6	-	
Response time (rise)	Tr	φ=0°, θ=0°	-	150	250	ms
Response time (fall)	Tf	φ=0°, θ=0°	-	150	250	ms

5.0 BLOCK DIAGRAM

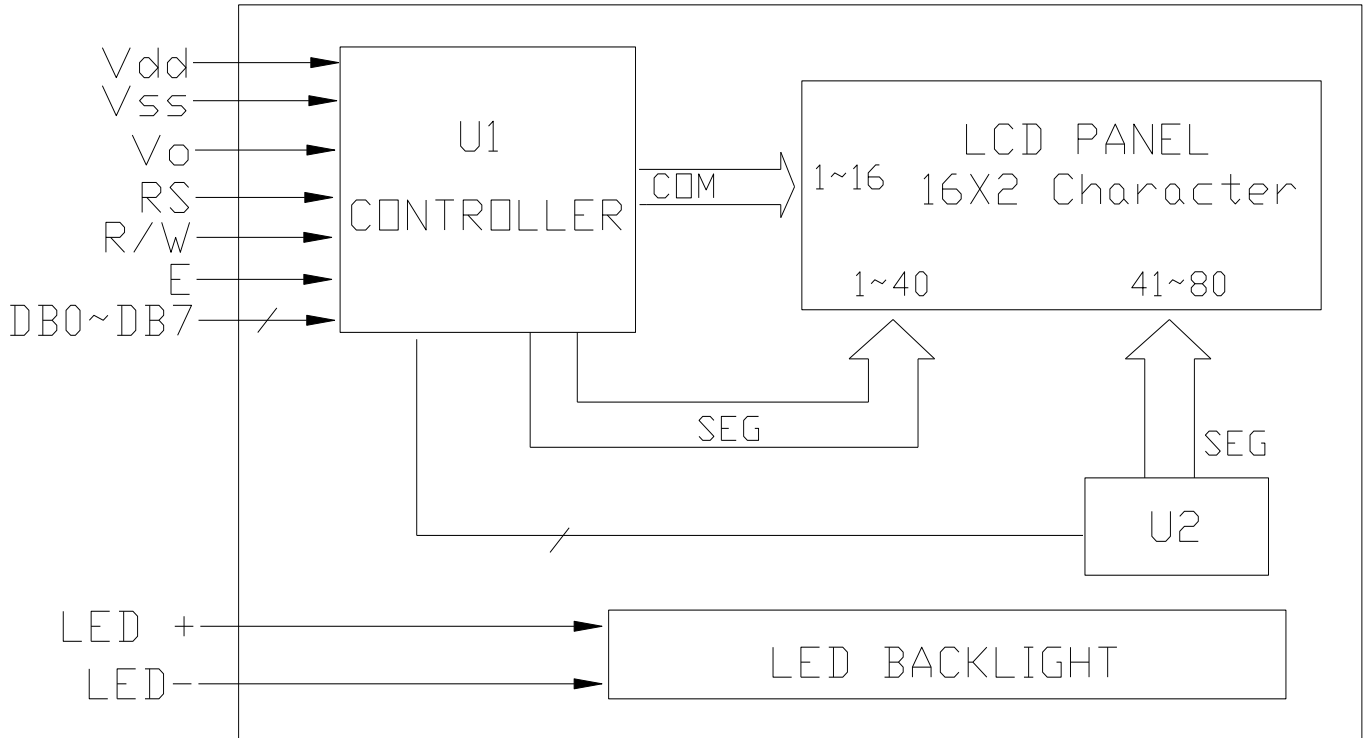

6.0 PIN ASSIGNMENT

Pin No.	Symbol	Function
1	Vss	Ground
2	Vdd	+5.0V
3	Vo	LCD contrast adjust
4	RS	Register select
5	R/W	Read / write
6	E	Enable
7	DB0	Data bit 0
8	DB1	Data bit 1
9	DB2	Data bit 2
10	DB3	Data bit 3
11	DB4	Data bit 4
12	DB5	Data bit 5
13	DB6	Data bit 6
14	DB7	Data bit 7
15	A	Power Supply for BL+5.0V
16	K	Power Supply for BL-

7.0 POWER SUPPLY

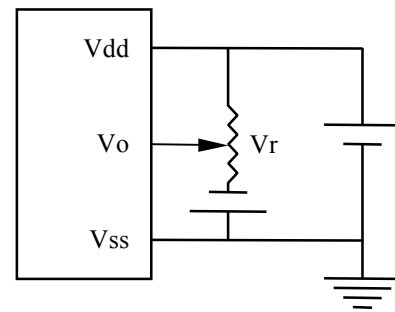
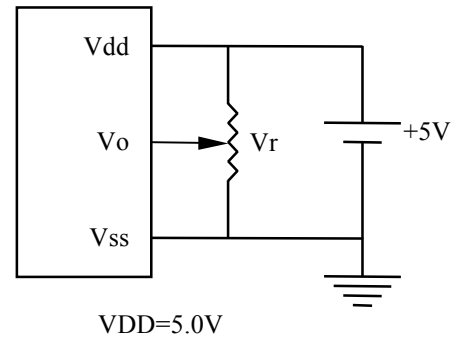

Vr = 10KΩ ~ 20KΩ

8.0 TIMING CHARACTERISTICS

Item	Symbol	Test Condition	Min.	Typ.	Max.	Unit
Enable cycle time	t _c	Fig. a, Fig. b	500	-	-	ns
Enable pulse width	t _w	Fig. a, Fig. b	220	-	-	ns
Enable rise/fall time	t _r , t _f	Fig. a, Fig. b	-	-	25	ns
RS, R/W set up time	t _{su}	Fig. a, Fig. b	40	-	-	ns
RS, R/W hold time	t _h	Fig. a, Fig. b	10	-	-	ns
Data delay time	t _d	Fig. b	-	-	120	ns
Data set up time	t _{dsu}	Fig. a	60	-	-	ns
Data hold time	t _{dH}	Fig. a, Fig. b	20	-	-	ns

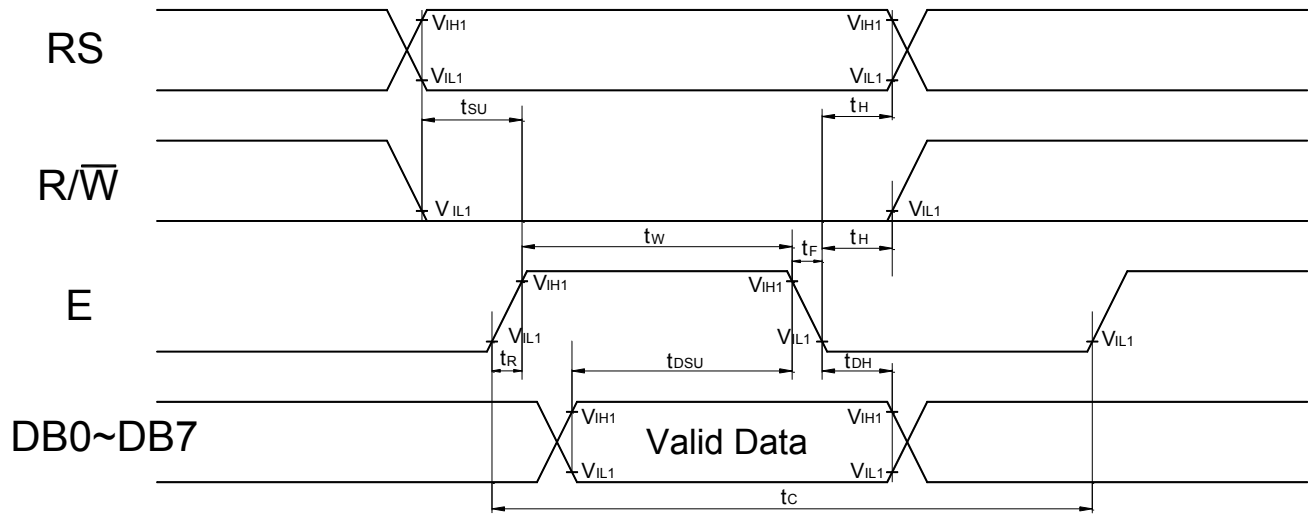

Fig. a Interface timing (data write)

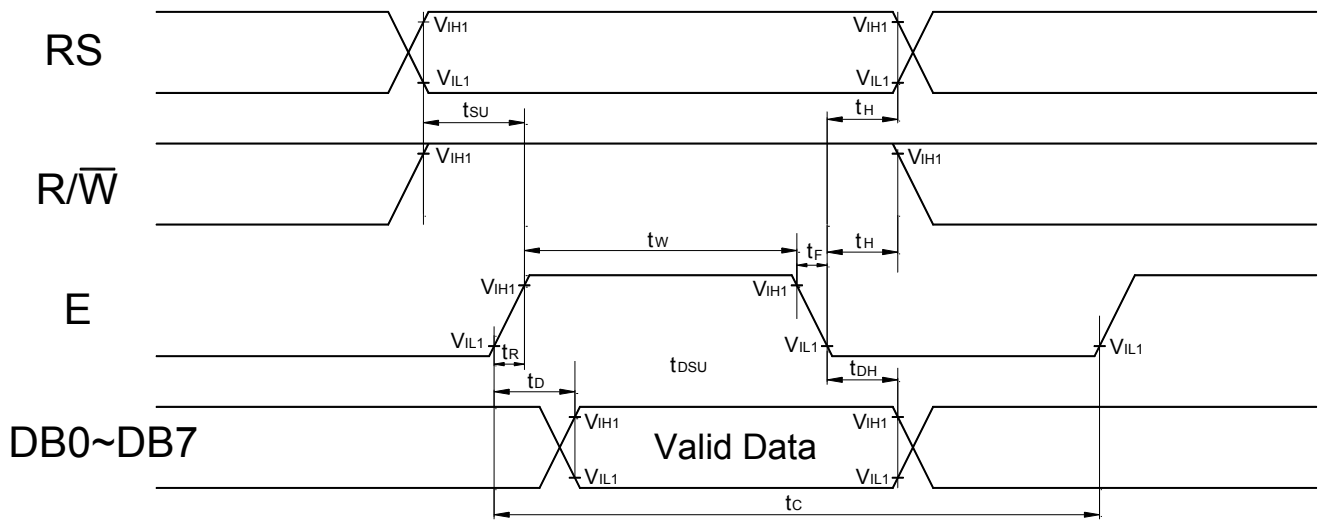
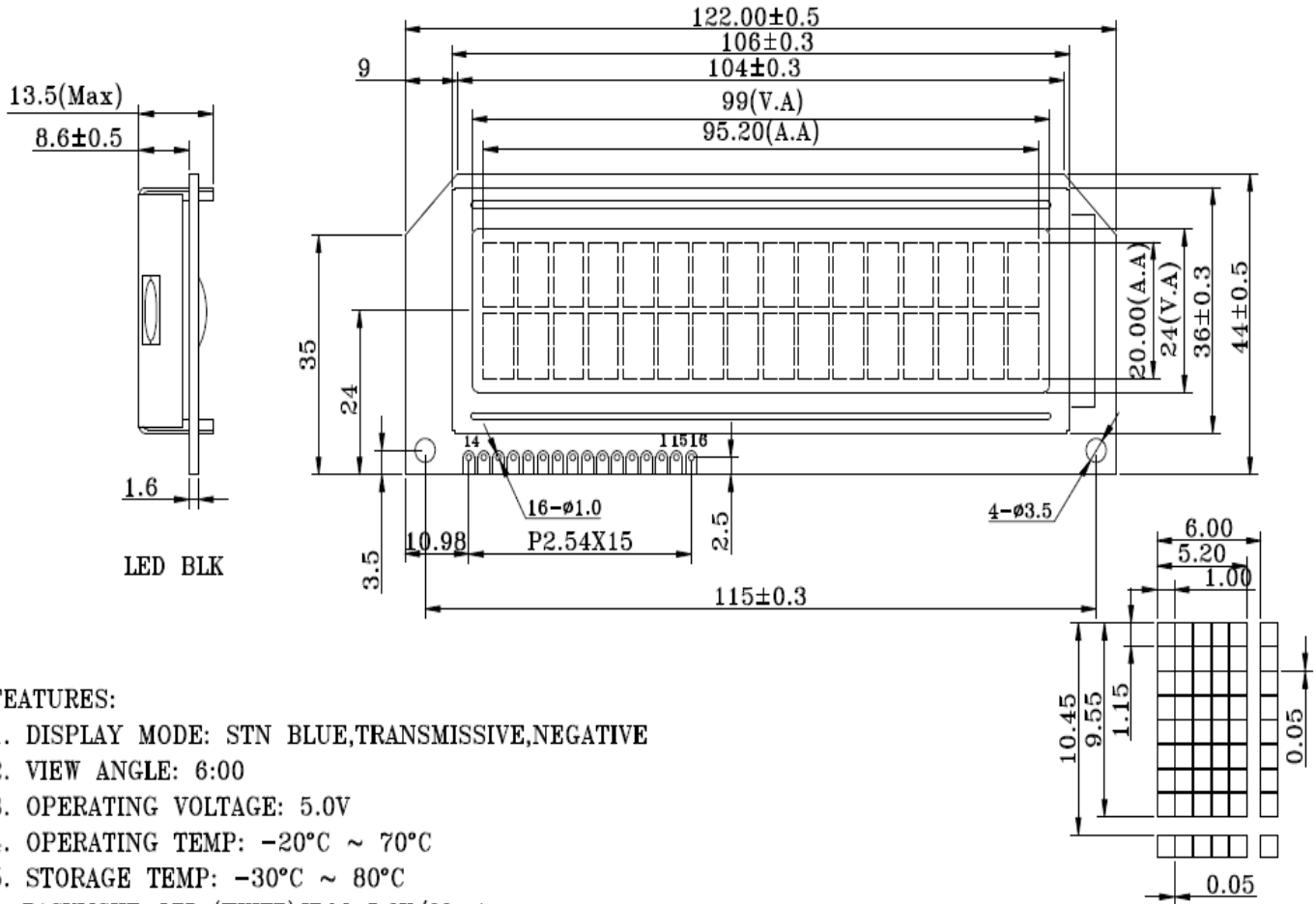

Fig. b Interface timing (data read)

9.0 MECHANICAL DIAGRAM



- FEATURES:**
1. DISPLAY MODE: STN BLUE, TRANSMISSIVE, NEGATIVE
 2. VIEW ANGLE: 6:00
 3. OPERATING VOLTAGE: 5.0V
 4. OPERATING TEMP: -20°C ~ 70°C
 5. STORAGE TEMP: -30°C ~ 80°C
 6. BACKLIGHT: LED (WHITE), V_{bkl}=5.0V/60mA
 7. DRIVER: ST7066U-0A OR EQUIVALENT

TOLERANCES UNLESS OTHERWISE SPECIFIED ±0.2

PIN	1	2	3	4	5	6	7	8
SIGNAL	VSS	VDD	V0	RS	R/W	E	DB0	DB1
PIN	9	10	11	12	13	14	15	16
SIGNAL	DB2	DB3	DB4	DB5	DB6	DB7	A	K

厦门精显电子有限公司
XIAMEN PRECISE DISPLAY CO., LTD.

确认:	绘图: GAO	绘图编号: PCM1602S-NS(W)-BBW-UN	单位: mm
	审核: ZHUNAG	客户编号:	日期: 2021.05.28
	批准: ZHUNAG	图纸版号: V1.0	页数: 1/1

10.0 RELIABILITY TEST

Storage Condition	Content	Evaluations and Assessment*			
		Current Consumption	Oozing	Contrast	Other Appearances
Operation at high temperature and humidity	70°C,90% RH,240hrs	Twice initial value or less	none	More than 80% of initial value	No abnormality
High temperature storage	80°C, 240hrs	Twice initial value or less	none	More than 80% of initial value	No abnormality
Low temperature storage	-30°C, 240hrs	Twice initial value or less		More than 80% of initial value	No abnormality

*Evaluations and assessment to be made two hours after returning to room temperature (25°C±5°C).

*The LCDs subjected to the test must not have dew condensation.

11.0 DISPLAY CHARACTER ADDRESS

16*2 Module DDRAM Address:

1	2	3	4	5	6	7	8	9	10	11	12	13	14	15	16
00	01	02	03	04	05	06	07	08	09	0A	0B	0C	0D	0E	0F
40	41	42	43	44	45	46	47	48	49	4A	4B	4C	4D	4E	4F

12.0 DISPLAY INSTRUCTION TABLE

COMMAND	R S	R/ W	DB 7	DB 6	DB 5	DB 4	DB 3	DB 2	DB 1	DB 0	DESCRIPTION	Executing time fosc=250khz
Clear Display	0	0	0	0	0	0	0	0	0	1	Clears Display & Returns to Address 0.	1.64ms
Cursor at Home	0	0	0	0	0	0	0	0	1	x	Returns Cursor to Address 0. Also returns the display being shifted to the original position. DDRAM contents remain unchanged.	1.64ms
Entry Mode Set	0	0	0	0	0	0	0	1	I/D	S	I/D: Set Cursor Moving Direction I/D=1: Increment I/D=0: Decrement S: Specify Shift of Display S=1: The display is shifted S=0: The display is not shifted	40µs
Display ON/OFF Control	0	0	0	0	0	0	1	D	C	B	Display D=1: Display on D=0: Display off Cursor C=1: Cursor on C=0: Cursor off Brink B=1: Brink on B=0: Brink off	40µs
Cursor / Display Shift	0	0	0	0	0	1	S/C	R/L	x	x	Moves cursor or shifts the display w/o changing DD RAM contents S/C=0: Cursor Shift (RAM unchanged) S/C=1: Display Shift (RAM unchanged) R/L=1: Shift to the Right R/L=0: Shift to the Left	40µs
Function Set	0	0	0	0	1	DL	N	F	x	x	Sets data bus length (DL), # of display lines (N), and character fonts (F). DL=1: 8 bits F=0: 5x7 dots DL=0: 4 bits F=1: 5x10 dots N=0: 1 line display N=1: 2 lines display	40µs
Set CG RAM Address	0	0	0	1	Character Generator (CG) RAM Address					Sets CG RAM address. CG RAM data is sent and received after this instruction.		40µs
Set DD RAM Address	0	0	1	Display Data (DD) RAM Address / Cursor Address					Sets DD RAM address. DD Ram data is sent and received after this instruction.		40µs	
Busy Flag / Address Read	0	1	B F	Address counter used for both DD & CG RAM address					Reads Busy Flag (BF) and address counter contents.		40µs	
Write Data	1	0	Write Data								Writes data into DDRAM or CGRAM.	46µs
Read Data	1	1	Read Data								Reads data from DDRAM or CGRAM.	46µs

x: Don't Care

13.0 STANDARD CHARACTER PATTERNS

Lower 4 Bits \ Upper 4 Bits	0000	0001	0010	0011	0100	0101	0110	0111	1000	1001	1010	1011	1100	1101	1110	1111
xxxx0000	CG RAM (1)			0	a	P	`	P				-	9	3	α	ρ
xxxx0001	(2)		!	1	A	Q	a	q			。	ア	チ	△	△	q
xxxx0010	(3)		"	2	B	R	b	r			「	イ	ツ	×	β	θ
xxxx0011	(4)		#	3	C	S	c	s			」	ウ	テ	モ	ε	∞
xxxx0100	(5)		\$	4	D	T	d	t			、	イ	ト	ト	μ	Ω
xxxx0101	(6)		%	5	E	U	e	u			・	オ	ナ	1	ε	ü
xxxx0110	(7)		&	6	F	V	f	v			ヲ	カ	ニ	ヨ	ρ	Σ
xxxx0111	(8)		'	7	G	W	g	w			ア	キ	ヌ	ウ	g	π
xxxx1000	(1)		(8	H	X	h	x			イ	ク	ネ	リ	γ	∞
xxxx1001	(2))	9	I	Y	i	y			ウ	ケ	ル	ル	'	γ
xxxx1010	(3)		*	:	J	Z	j	z			エ	コ	ハ	レ	j	κ
xxxx1011	(4)		+	;	K	[k	[オ	サ	ヒ	ロ	°	κ
xxxx1100	(5)		,	<	L	¥	l	l			カ	シ	フ	ク	φ	κ
xxxx1101	(6)		-	=	M]	m]			ユ	ズ	ハ	ン	も	÷
xxxx1110	(7)		.	>	N	^	n	^			ヨ	セ	ホ	ウ	ñ	
xxxx1111	(8)		/	?	O	_	o	_			ッ	ソ	マ	マ	ö	■

Note: The character generator RAM is the RAM with which the user can rewrite character patterns by program.