

DEVICE SPECIFICATION FOR PYROELECTRIC IR-DETECTOR

CUSTOMER :
TYPE : LHI 968
PART-NO. : 3866
No. of samples :

Dual element detector, serial opposed format, two elements based on pyroceramic, FET in source follower configuration.
For EMI protection a capacitor is internally connected between Source and Ground and a resistor between FET and Drain pin.

This specification is provided by

Perkin Elmer Optoelectronics GmbH & Co. KG,- Wiesbaden.

It covers the complete technical data of a pyroelectric IR detector. In case of samples attached to this paper, these have been taken randomly from normal production output. All detectors have met the requirements of Perkin Elmer test-specifications and passed outgoing inspection.

We kindly ask for approval with the return of a signed copy.

Checked:

Date: 10.09.03

Customer approval:

Date:

Electrical Configuration:

The sensing elements are connected to built-in FET in source follower circuit, connections "Drain-Source-Ground". It is recommended to use a load resistor of 47 kΩ.

Electrical data:

Unless specified differently, all data refer to 25°C:

Responsivity: **min.: 3.3 kV/W** **typ.: 4.0 kV/W**

Responsivity is measured within spectral range 7 - 14 μm as per fig. 3 at 1Hz.

Match: **max.: 10 %**

Electrical balance (match) is measured with same test set up as responsivity, both elements exposed to radiation. A percent value is calculated as

$$\frac{100 \times s_m}{s} \quad s_m : \text{signal (match)}$$
$$s : \text{signal of left or right element.}$$

Noise: **max.: 50 μV_{pp}** **typ.: 20 μV_{pp}**

After a 10 minute settling time, noise is monitored for the duration of 1500 sec. at a temperature of 25°C, shut from infrared energy, electrical bandwidth of 0.4 to 10Hz.

Operating voltage: $V_{DD} = 2-12 \text{ V}$

Source voltage: $V_S = 0.2-1.5 \text{ V}$

Drain-source voltage: $V_{DS} = \text{min } 0.5 \text{ V}$

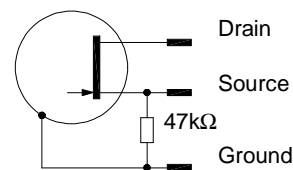

Fig.1: Test circuit

Typical Responsivity vs. Frequency

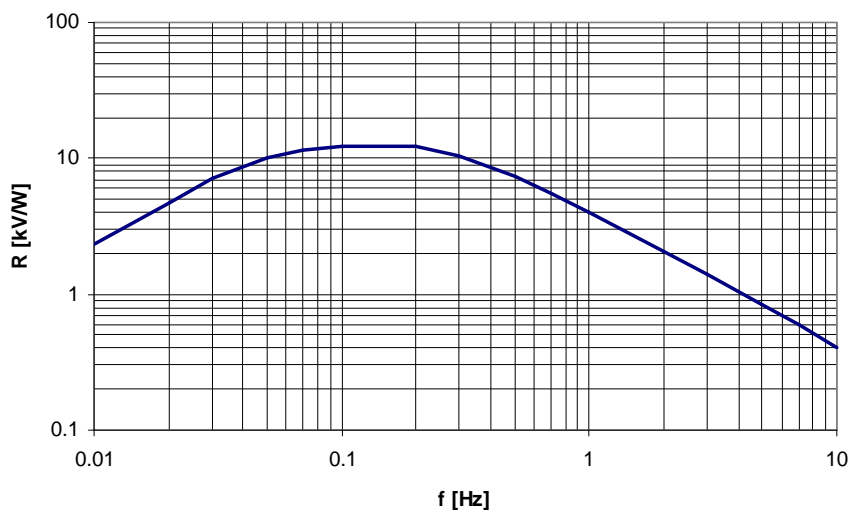

Fig.2: Frequency response

Sample data

The samples attached to this specification have been randomly selected. Test equipment as per fig. 3 and fig.4.

Tab.1: Sample data

Sample no.	R _A [kV/W]	R _B [kV/W]	Match [kV/W]	Offset [V]
1				
2				
3				
4				
5				
6				
7				
8				
9				
10				

Test Set up

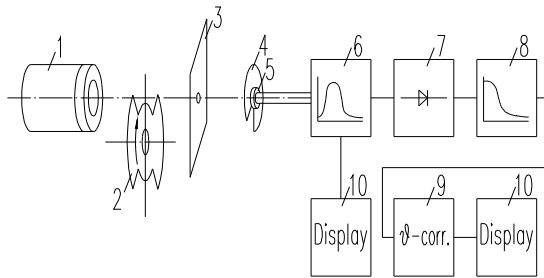

- 1: Black Body Radiator 373K = 100°C
- 2: 1 Hz Chopper
- 3: Aperture
- 4: Cover plate
- 5: Detector
- 6: Bandpass filter 1 Hz
- 7: Rectifier
- 8: Lowpass filter
- 9: Temperature compensation
- 10: Display

Fig.3: Test Set – up

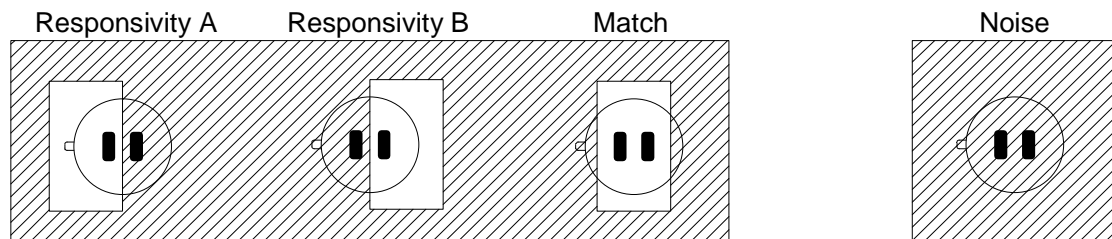

Fig.4.: Responsivity measurement

Spectral range:

The spectral range of the detector is determined by filter built in (window).

Substrate: Silicon, multilayer coated

Cut – on: 5.5 ± 0.3 μm

Transmission: T > 77% average between 7 μm and 14 μm

Blocking: T < 0.1% for λ < 5 μm

Configuration:

Housing: TO- 5 metal housing with infrared transparent window

Element size: 2 x 1 mm², spacing 1 mm, see also drawing: 2/70981

Connections: Refer to drawing: 2/70981

Field of View

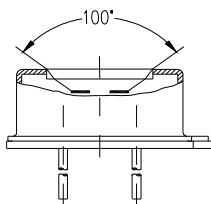

Fig.5: Field of View

Operating temperature: -40°C to +85°C

The electrical parameters may vary from specified values accordance with their temperature dependence.

Storage temperature: -40°C to +85°C

Avoid storage under high humid environment.

Microphonic noise: max: 30 μV_{rms} /g

Perkin Elmer IR-detectors covered herein have passed qualification test for microphonic noise in x-y-z axis, exciting frequencies from 5Hz to 2kHz.

Humidity:

The IR-detector shall not increase noise or decrease responsivity when exposed to 95% r.H. at 30°C. Operation below dew point might effect performance.

Hermetic seal:

This IR-detector is sealed to pass a He-leakage test with maximum leak rate of 10^{-8} mbar·l·s⁻¹.

Quality:

Perkin Elmer is a ISO 9001 certified manufacturer with established SPC and TQM. Detector out-going inspections include the parameters Responsivity, Match, Offset, Noise, Gross leak (Mil Std 883 method 1014C1) on 100%. Individual data are not stored, statistical details can be disclosed on request.

Handling:

Electrostatic charges may destroy the detector. We recommend to apply precautions necessary for ESD devices to avoid damages. Do not apply physical force to detector leads. Do not expose detector to aggressive detergents such as freon, trichlorethylene, etc.

Solder conditions:

Hand soldering and standard wave soldering process may be applied. Avoid heat exposure to the top and the window of the detector. Reflow soldering is not recommended.

The reproduction, transmission or use of this document or its contents is not permitted without express written authority. Offenders will be liable for damages. All rights, including rights created by patent grant or registration of a utility model or design are reserved.

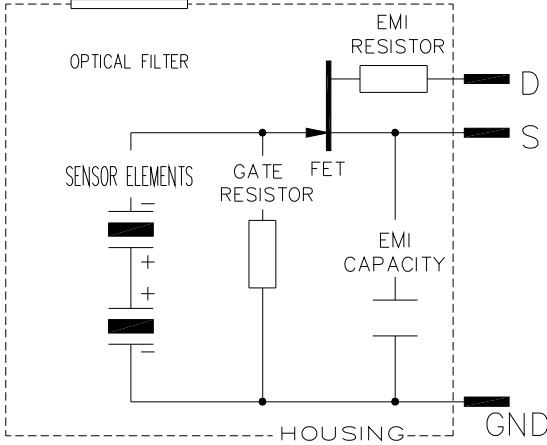
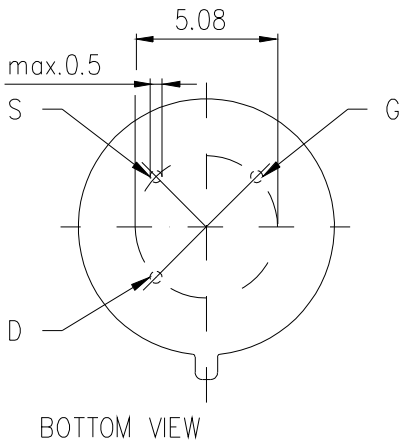
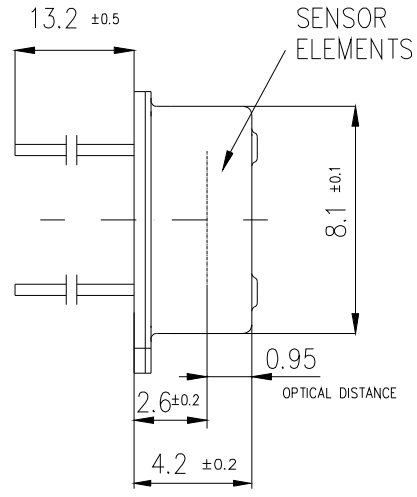
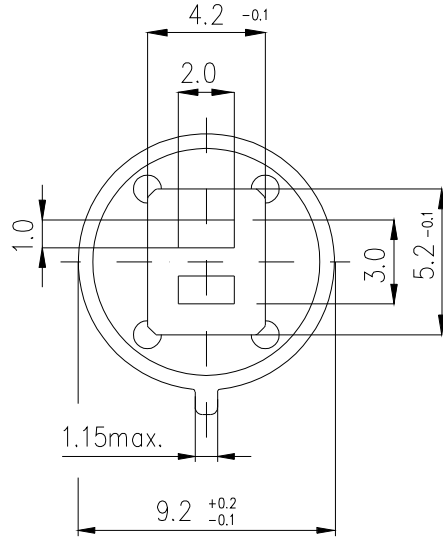

Weitergabe sowie Vervielfältigung dieser Unterlage, Verwertung und Mitteilung ihres Inhalts ist nicht gestattet, soweit nicht ausdrücklich zugestanden. Zuwiderhandlungen verpflichten zu Schadenersatz. Alle Rechte vorbehalten, insbesondere für den Fall der Patenterteilung oder GM-Eintragung.

Allgemeintoleranzen GENERAL TOLERANCES				Werkstückkanten/EDGES OF WORKING-PARTS ACC. DIN 6784		Form- u. Lagetoleranzen GEOMETRICAL TOLERANCES	
		Datum DATE	Name NAME	Werkstoff MATERIAL		 PerkinElmer® optoelectronics.	
		Gez. DRAWN BY	20.1.98	Tkocz			
		Gepr. CHECKED BY					
		Maßstab SCALE	Benennung/TITLE				
		5:1	ELEMENTORIENTATION AND CONNECTIONS LHI 968			Zeichnung Nr./DRAWING NO. 2/70981	
						Liefervorschrift/SPECIFICATION	
						Ersatz für/REPLACEMENT FOR	
						Ersetzt durch/REPLACED BY	
1	2/3758	21.05.99	Tkocz				
Index NO.	Änderung REVISION	Datum DATE	Name NAME				

A4.dwg