

# **L506 Hardware Design**

---

**LTE Module Series**

**Version:** V2.7

**Date:** 2020-02-29

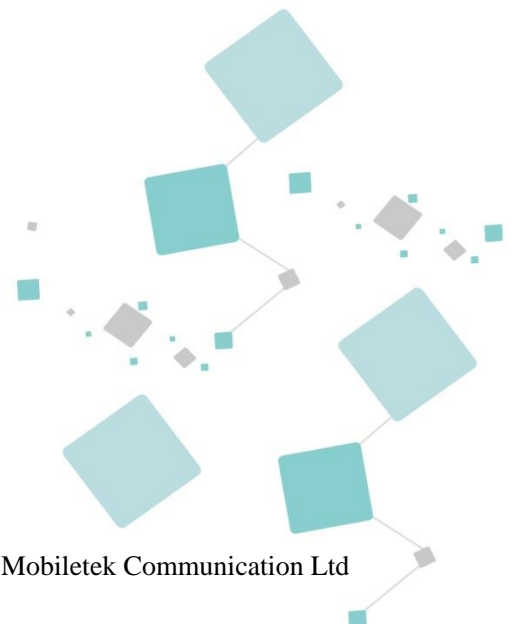

#### Notice

Some features of the product and its accessories described herein rely on the software installed, capacities and settings of local network, and therefore may not be activated or may be limited by local network operators or network service providers.

Thus, the descriptions herein may not exactly match the product or its accessories which you purchase. Shanghai Mobiletek Communication Ltd reserves the right to change or modify any information or specifications contained in this manual without prior notice and without any liability.

#### Copyright

This document contains proprietary technical information which is the property of Shanghai Mobiletek Communication Ltd. copying of this document and giving it to others and the using or communication of the contents thereof, are forbidden without express authority. Offenders are liable to the payment of damages. All rights reserved in the event of grant of patent or the registration of a utility model or design. All specification supplied herein are subject to change without notice at any time.

#### DISCLAIMER

ALL CONTENTS OF THIS MANUAL ARE PROVIDED "AS IS". EXCEPT AS REQUIRED BY APPLICABLE LAWS, NO WARRANTIES OF ANY KIND, EITHER EXPRESS OR IMPLIED, INCLUDING BUT NOT LIMITED TO, THE IMPLIED WARRANTIES OF MERCHANTABILITY AND FITNESS FOR A PARTICULAR PURPOSE, ARE MADE IN RELATION TO THE ACCURACY, RELIABILITY OR CONTENTS OF THIS MANUAL.

TO THE MAXIMUM EXTENT PERMITTED BY APPLICABLE LAW, IN NO EVENT SHALL SHANGHAI MOBILETEK COMMUNICATION LTD BE LIABLE FOR ANY SPECIAL, INCIDENTAL, INDIRECT, OR CONSEQUENTIAL DAMAGES, OR LOSS OF PROFITS, BUSINESS, REVENUE, DATA, GOODWILL SAVINGS OR ANTICIPATED SAVINGS REGARDLESS OF WHETHER SUCH LOSSES ARE FORSEEABLE OR NOT.

## Version History

Date	Version	Description of change	Author
2016-03-09	V1.0	Initial	
2016-06-02	V1.1	Add UART design description	
2016-06-25	V1.2	Update Stencil file	
2016-06-28	V1.3	Update Figure information	
2016-06-29	V1.4	Update RF parameter	
2016-08-15	V1.5	1. Add WIFI version information 2. Add storage and package part	
2016-09-15	V1.6	Add CDMA parameter	
2017-04-06	V1.6.1	Added LD Series	
2017-10-26	V1.6.2	Added L506A Series	
2017-11-10	V1.6.3	Update Band information	
2018-04-29	V1.9	Update Product Model	
2018-11-10	V2.0	Update product baking instructions	
2018-11-15	V2.1	Added L506X series	
2018-11-21	V2.2	Update product model information	
2018-12-26	V2.3	Update product Pin information	
2019-07-26	V2.4	Added L506X(G) series	
2019-09-29	V2.5	Update PCM description	
2019-11-13	V2.6	Added L506SC series	
2020-02-29	V2.7	Update edge and gprs spec	

## Contents

<b>1 ABOUT THIS DOCUMENT</b> .....	<b>7</b>
<b>1.1 Applicable scope</b> .....	<b>7</b>
<b>1.2 Writing purpose</b> .....	<b>7</b>
<b>1.3 Support and reference documents list</b> .....	<b>7</b>
<b>1.4 Terms and Abbreviations</b> .....	<b>8</b>
<b>2 PRODUCT OVERVIEW</b> .....	<b>9</b>
<b>2.1 Package Dimensions</b> .....	<b>11</b>
<b>2.2 Product Function Outline</b> .....	<b>15</b>
2.2.1 Hardware Diagram.....	15
2.2.2 Radio frequency function.....	16
<b>3 INTERFACE DESCRIPTION</b> .....	<b>20</b>
<b>3.1 PIN Definition</b> .....	<b>20</b>
3.1.1 Pin I/O parameter definition.....	20
3.1.2 Pin Map.....	20
3.1.3 PIN Definition and function description.....	21
<b>3.2 Operating condition</b> .....	<b>27</b>
<b>3.3 Digital I/O characteristics</b> .....	<b>28</b>
<b>3.4 Power Interface</b> .....	<b>28</b>
3.4.1 Power supply pin description.....	28
3.4.2 Power supply requirements.....	29
3.4.3 Power Supply Design Guide.....	30
3.4.4 Recommended Power supply circuit.....	31
3.4.5 Power Supply Layout guide.....	32
<b>3.5 USIM interface</b> .....	<b>32</b>
3.5.1 Pin definition.....	32
3.5.2 Design Guide.....	33
3.5.3 USIM interface reference circuit.....	33
<b>3.6 PCM interface</b> .....	<b>33</b>
3.6.1 PCM interface definition.....	33
3.6.2 PCM interface application.....	35
<b>3.7 USB2.0 interface</b> .....	<b>36</b>
3.7.1 USB interface pin definition.....	36
3.7.2 USB Interface application.....	36
<b>3.8 UART Interface</b> .....	<b>37</b>
3.8.1 Pin description.....	37
3.8.2 UART interface application.....	38
<b>3.9 Power on/off and reset interface</b> .....	<b>41</b>

3.9.1 Pin definition.....	41
3.9.2 Power on sequence.....	41
3.9.3 Power off sequence.....	42
3.9.4 Reset sequence.....	43
3.9.5 Power on/off and reset interface application.....	43
<b>3.10 Interactive interface.....</b>	<b>45</b>
3.10.1 Pin definition.....	45
3.10.2 interactive interface application.....	45
<b>3.11 Net Light interface.....</b>	<b>46</b>
3.11.1 Pin define.....	46
3.11.2 Net light application.....	46
<b>3.12 SD card interface.....</b>	<b>47</b>
3.12.1 Pin descriptions.....	47
3.12.2 SD card interface design guideline.....	48
3.12.3 SD card signal PCB line rules.....	49
<b>3.13 System boot configuration and download.....</b>	<b>49</b>
3.13.1 Pin definition.....	49
3.13.2 Boot configuration and force USB interface application.....	49
<b>3.14 WIFI interface (WIFI edition).....</b>	<b>50</b>
3.14.1 WIFI interface definition.....	50
3.14.2 WIFI interface application.....	51
<b>3.15 Analog and Digital conversion (ADC) interface.....</b>	<b>52</b>
<b>3.16 I2C interface.....</b>	<b>52</b>
3.16.1 I2C pin definition.....	52
<b>3.17 Antenna interface.....</b>	<b>53</b>
3.17.1 RF signal PCB layout guide.....	53
3.17.2 applications.....	54
<b>4 PRODUCT CHARACTERISTICS.....</b>	<b>57</b>
<b>4.1 Absolute parameters.....</b>	<b>57</b>
<b>4.2 Operation condition.....</b>	<b>57</b>
4.2.1 Operation voltage.....	57
4.2.2 Work mode.....	57
4.2.3 current consumption.....	59
<b>4.3 Working and storage temperature.....</b>	<b>61</b>
<b>4.4 ESD performance.....</b>	<b>62</b>
<b>5 DESIGN GUIDELINE.....</b>	<b>63</b>
<b>5.1 General design rules and requirements.....</b>	<b>63</b>
<b>5.2 Reference circuit.....</b>	<b>63</b>
<b>5.3 RF part design guideline.....</b>	<b>63</b>
<b>5.3.1 Early antenna design considerations.....</b>	<b>63</b>
<b>5.4 EMC and ESD design advice.....</b>	<b>64</b>

**5.5 PCB Recommended land pattern.....64**

**5.6 Products recommended upgrade.....66**

**6 MANUFACTURERS ..... 67**

**6.1 Steel mesh design .....67**

**6.2 Temperature curve.....68**

**6.3 The Moisture Sensitivity Level (MSL).....69**

**6.4 Baking Requirements .....70**

**7 PACKAGE STORAGE INFORMATION ..... 71**

**7.1 Package information.....71**

    7.1.1 Tape and reel information ..... 71

    7.1.1 Package information..... 71

**7.2 Bagged storage conditions.....72**

**8 SAFETY INFORMATION ..... 73**

LYNQ  
CONFIDENTIAL

# 1 About this document

## 1.1 Applicable scope

This document describes the L506 series 4G LTE LCC Module (hereinafter referred to as L506), the basic specifications, product electrical characteristics, design guidance and hardware interface development guidance. Users need to follow this documentation requirements and guidance for design. This document applies only to L506 products in the application development.

## 1.2 Writing purpose

This document provides the design and development basis for the product users. By reading this document, users can have a whole understanding of the product, the technical parameters of the product have a clear understanding, and can be used in this document to complete the development of wireless 4G Internet access functions.

This hardware development document not only provides the product functional features and technical parameters, but also provides product reliability testing and related testing standards, business functions to achieve process, RF performance indicators and user circuit design guidance.

## 1.3 Support and reference documents list

In addition to the hardware development documentation, we also provide a guide to the development board based on this product manual and software development instruction manual, 1-1 is supported as a list.

Table 1-1 support document list

No.	Documents
1	《L506AT Command User Guide》
2	《L506_SPEC.docx》
3	《L506EVBUUserManual》
4	《L506Schematic checklist》
5	《L506Layout checklist》
6	《L506_Reference Design_V3.pdf》
7	《L506_V3_DECAL.sch》
8	《L506_V3_DECAL.PCB》

## 1.4 Terms and Abbreviations

Table 1-2 is the Document relative Terms and Abbreviations.

Table1-2Terms and Abbreviations

Abbreviation	Descriptions
ESD	Electro-Static discharge
USB	Universal Serial Bus
UART	Universal Asynchronous Receiver Transmitter
SDCC	Secure Digital Card Controller
USIM	UniversalSubscriber Identification Module
SPI	Serial Peripheral Interface
I2C	Inter-Integrated Circuit
PCM	Pulse-coded Modulation
I/O	Input/output
LED	Light Emitting Diode
GPIO	General-purpose Input/Output
GSM	Global Standard for Mobile Communications
GPRS	General Packet Radio Service
WCDMA	Wideband Code Division Multi Access
UMTS	Universal Mobile Telecommunication System
HSDPA	High Speed Downlink Packet Access
HSUPA	High Speed Uplink Packet Access
AGPS	Assisted Global Positioning System
BER	Bit Error Rate
DL	Downlink
COEX	WLAM/LTE-ISM coexistence
SMPS	Switched-mode power supplies
LTE	Long Term Evolution
FDD	Frequency Division Duplexing
TDD	Time Division Duplexing
DPCH	Dedicated Physical Channel
DPCH_Ec	Average energy per PN chip for DPCH. DPCH



## 2 Product Overview

L506 is a series module and design for global market, It include standard series and LD series. User can choose the module based on the wireless network configuration. Inthis document, the supported radio band is described in the following items. This product is a LCC interface of 4G wireless internet module, with the high speed, small size, light weight, high reliability can be widely used in various products and devices with wireless internet access:

Table2-1 L506 series module type correspond band

频段支持		L506(B*)C L506LD L506X(G)C	L506(B*)E L506ELD L506X(G)E	L506(B*)CF L506CFLD L506X(G)CF	L506A L506ALD	L506SC
GSM	GSM900	●	●	●		●
	GSM1800	●	●	●		●
CDMA2000/ EVDO	BC0			●		
WCDMA	UMTS850				●	
	UMTS900	●	●	●		●
	UMTS1900				●	
	UMTS2100	●	●	●		●
TD-SCDMA	TD-SCDMA B34	●	●	●		
	TD-SCDMA B39	●	●	●		
LTE-TDD	TDD_LTE B38	●	●	●		●
	TDD_LTE B39	●	●	●		●
	TDD_LTE B40	●	●	●		●
	TDD_LTE B41	●	●	●		●
LTE-FDD	FDD_LTE B1	●	●	●		●
	FDD_LTE B2				●	
	FDD_LTE B3	●	●	●		●
	FDD_LTE B4				●	
	FDD_LTE B5	● <sup>(1)</sup>		● <sup>(1)</sup>	●	●
	FDD_LTE B7		●			
	FDD_LTE B8	●	●	●		●
	FDD_LTE B13				●	
	FDD_LTE B17				●	

	FDD_LTE B20		●			
GNSS <sup>(2)</sup>	GPS L1 BAND	●	●	●	●	
	GLONASS	●	●	●	●	
	BEIDOU	●	●	●	●	

\* B series products can support EXT BT interface

<sup>(1)</sup> It is necessary to confirm whether the order contains BAND5

<sup>(2)</sup> LD series and X(C/E/CF) series not support GNSS, XG(C/E/CF) support GNSS

Table2-2 Differences list between L506standard series ,L506LD series ,L506X series and L506SC series.

Feature	L506 Standard series	L506LD series	L506X(C/E/CF)	L506XG(C/E/CF)	L506SC
PCM	YES	NO	YES*	YES*	NO
GNSS	YES	NO	NO	YES	NO
WIFI Interface	YES	NO	NO	NO	NO
Diversity reception	YES	NO	NO	NO	NO

\*L506X(G)CF-2 not support PCM

#### Data transmission specifications

- LTE-FDD
  - Uplink up to 50Mbps,
  - Downlink up to 150Mbps
- LTE-TDD
  - Uplink up to 35Mbps,
  - Downlink up to 130Mbps
- TD-HSDPA/HSUPA
  - Uplink up to 2.2 Mbps,
  - Downlink up to 4.2Mbps
- TD-SCDMA
  - Uplink up to 128Kbps,
  - Downlink up to 384Kbps
- HSPA+
  - Uplink up to 5.76 Mbps,
  - Downlink up to 42 Mbps
- UMTS
  - Uplink/Downlink up to 384Kbps
- 1xEV-DO
  - Uplink up to 1.8Mbps,
  - Downlink up to 3.1Mbps
- EDGE Class 33:

- Max. 296Kbps (DL), Max. 236.8Kbps (UL)
- GPRS Class 33:
- Max. 107Kbps (DL), Max. 85.6Kbps (UL)

#### Interface

- SUB2.0
- UART
- USIM (3V/1.8V)
- GPIO
- ADC
- SDIO
- PCM
- SPI
- I2C
- NETLIGHT
- POWER KEY
- RESET

Dimensions (L×W×H) : 30mm×30mm×2.8mm



TOP VIEW

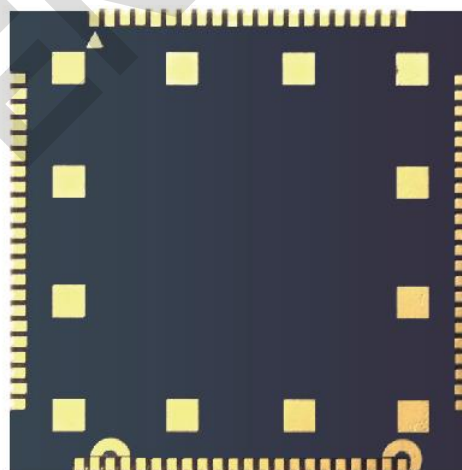

BOTTOM VIEW

Figure 2-1 Product Physical Map

## 2.1 Package Dimensions

The product module is 87-PIN LCC package module, in addition to signal pin, also contains many special heat welding disc to improve joint performance, mechanical strength and heat dissipation performance, the heat release welding disc 12 and uniform distribution in the bottom of the PCB. Package size is 30 x 30 mm, the height is 2.8 mm. Pin 1 position from the bottom of the belt angle welding plate to identify, the missing corner where the direction of the corresponding module angle pad, figure 2-2 is the product dimension type map:

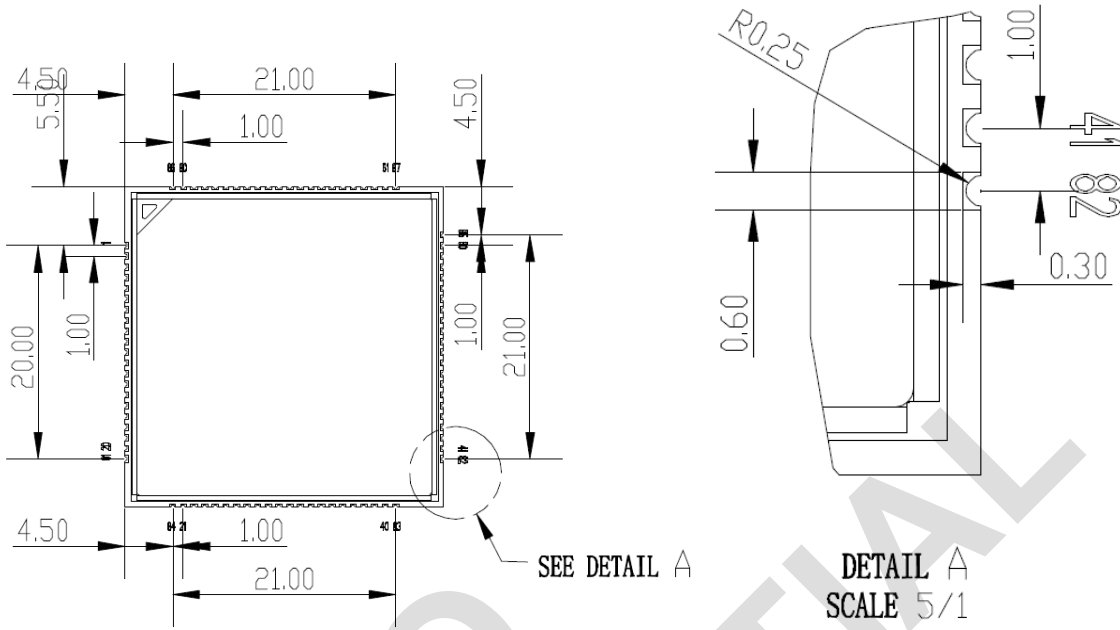

(a)Top Dimensions(Unit mm) (b)Top Detail(Unit mm)A

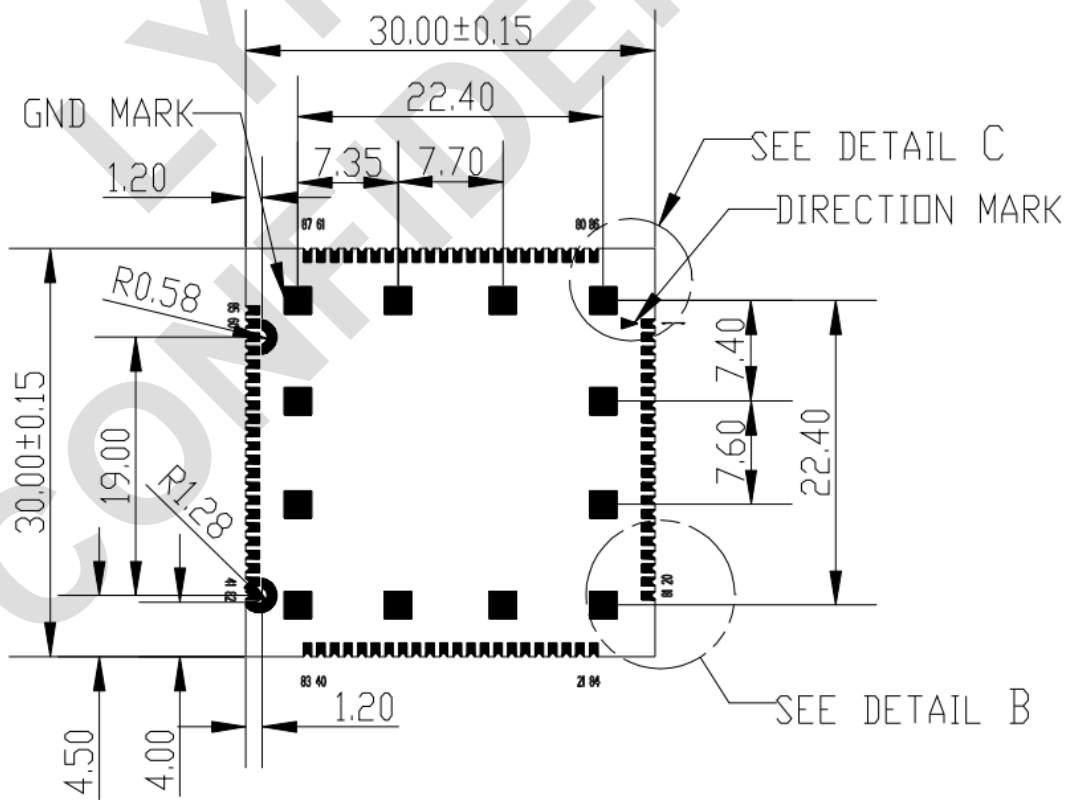

(c)Bottom Dimensions (Unit mm)

Note: antenna feed point in actual use of the customers don't need (PCB assembly, the stencil file).

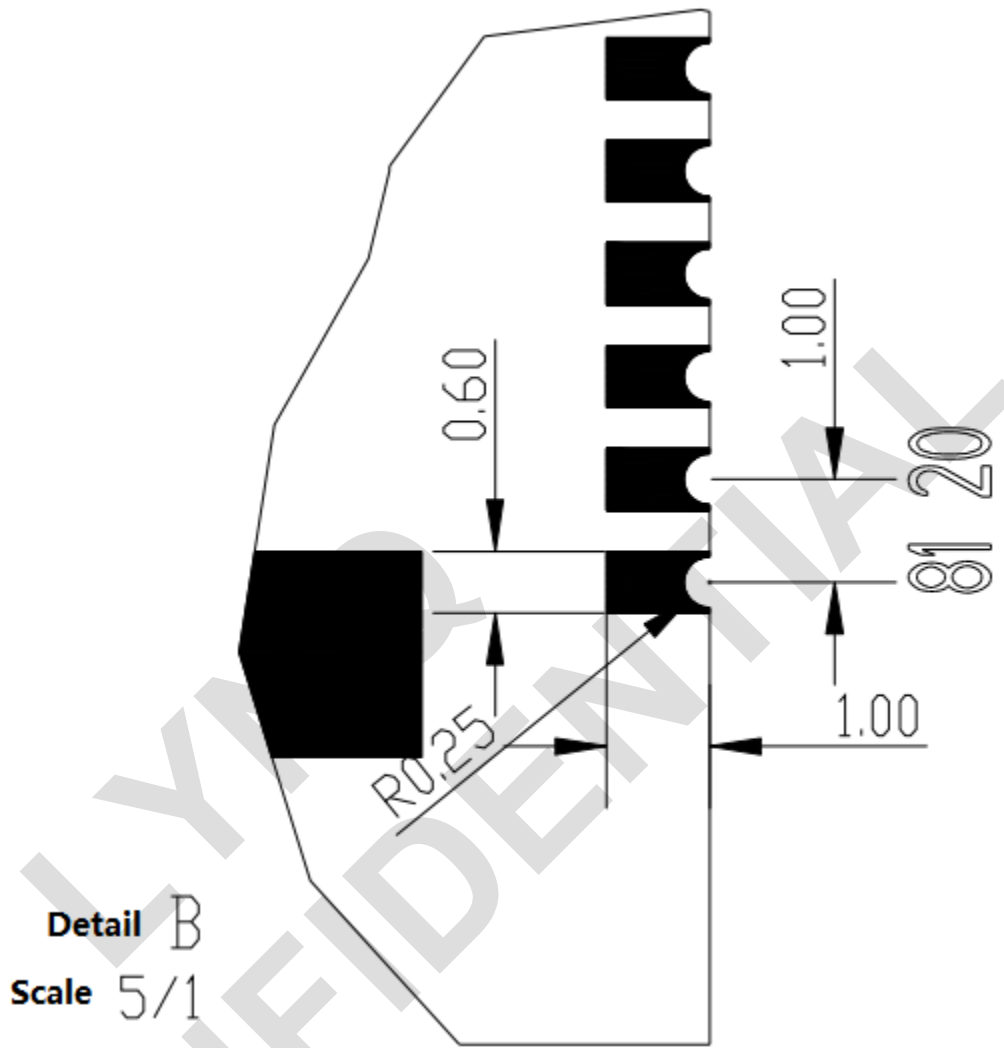

(d) Bottom Detail B (Unit mm)

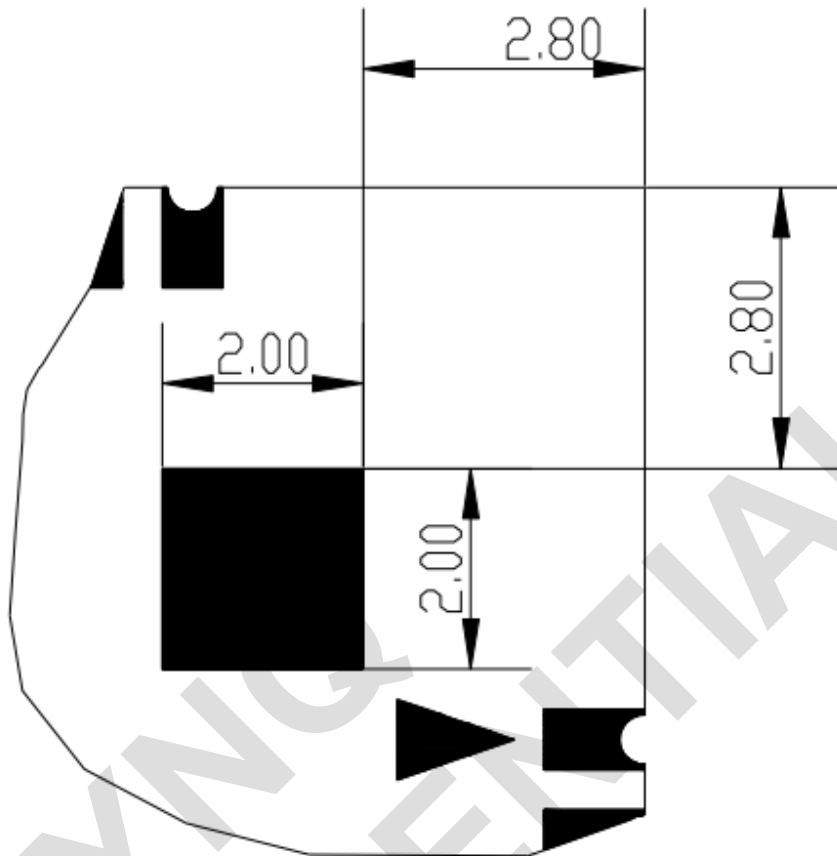

Detail C  
Scale 5/1

(e)Bottom Detail C(Unit mm)

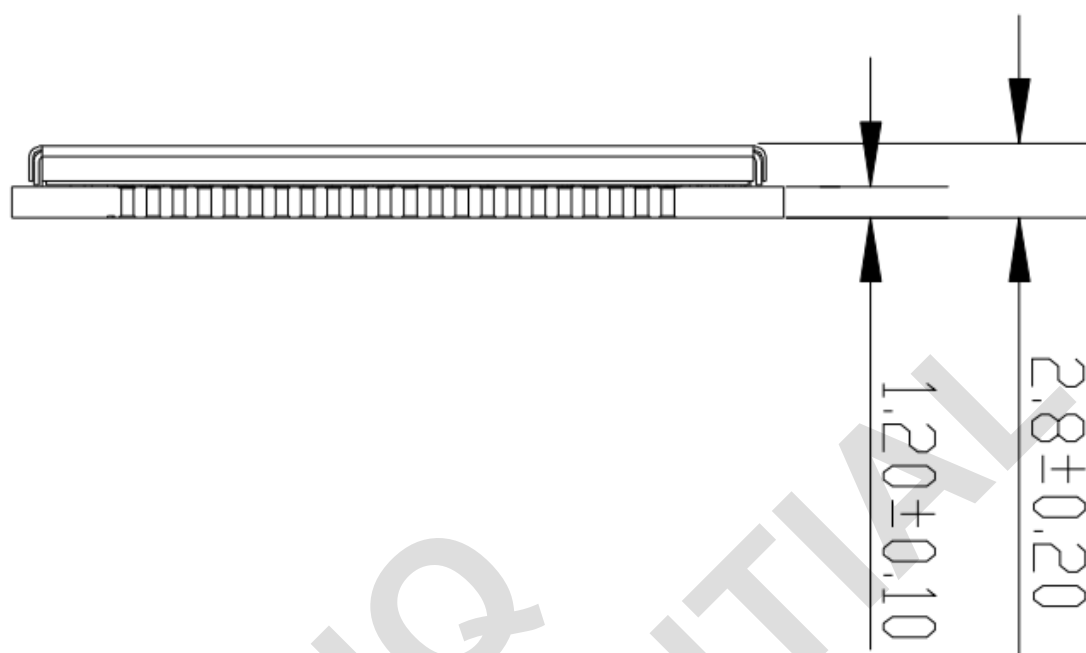

(e)Side view Dimensions(Unit mm)  
Figure 2-2Module Dimensions

## 2.2 Product Function Outline

### 2.2.1 Hardware Diagram

This product mainly includes the following signal group: USB Interface signal、USIM card Interface signal、I2C Interface signal、UART Interface signal、PCM Interface signal、UART Interface signal、WIFI Interface signal(WIFI Version)、SPI interface、Module startup、Module control signal、Power supply and ground. The global architecture of the L506 module is described in the figure below.

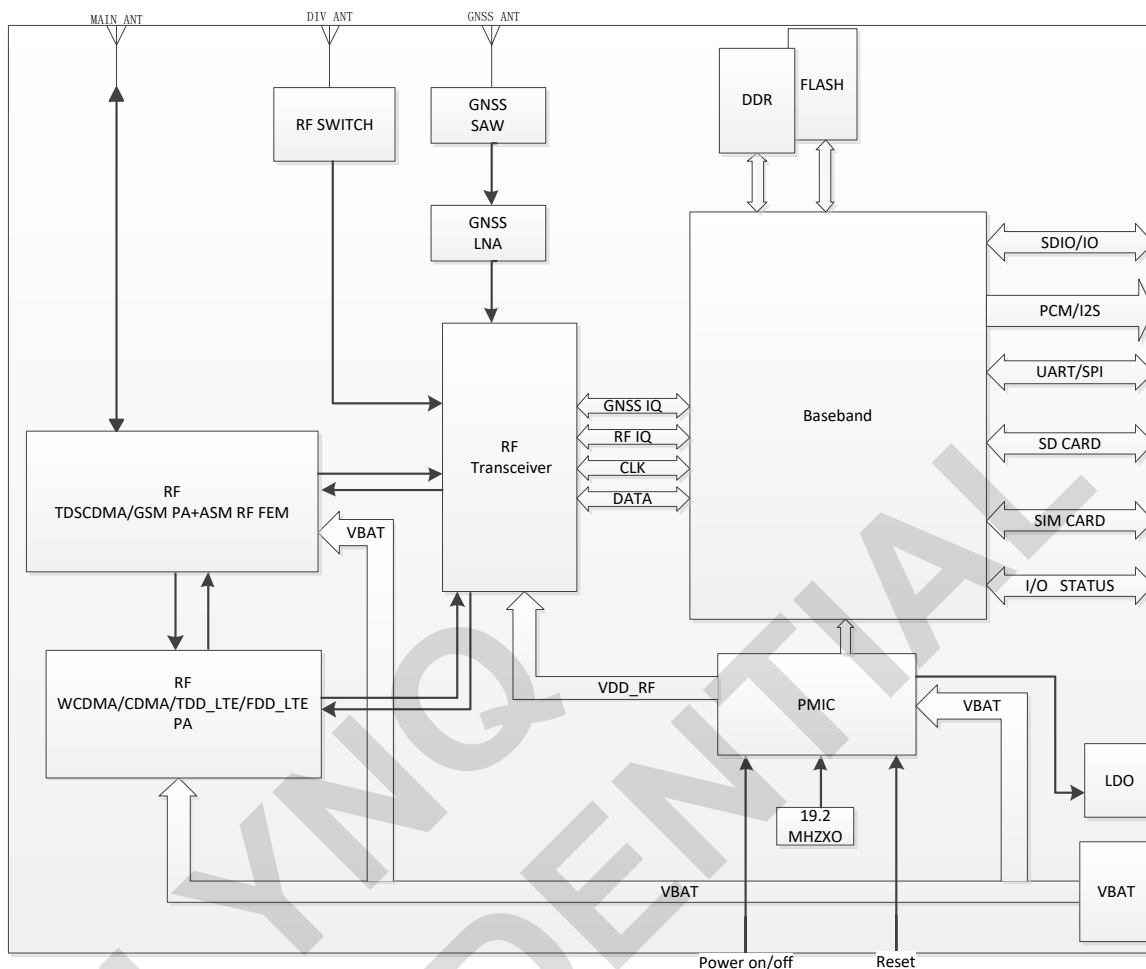

Figure 2-3 L506 System Functional Architecture

## 2.2.2 Radio frequency function

RF Function Overview:

- TDD-LTE B38/B39/B40/B41
- FDD-LTE B1/B2/B3/B4/B5/B7/B8/B12/B13/B17/B20
- TD-SCDMA B34/B39
- UMTS/HSDPA/HSPA+ B1/B2/B5/B8
- GSM/GPRS/EDGE 900/1800 MHz
- GPS/BEIDOU/GLONASS

The operating frequency range of the transmitter is shown in table 2-2.

Table 2-3RF frequency band

Working band	Upstream band (Uplink)	Downlink frequency (Downlink)
UMTS850	824 MHz — 849MHz	869 MHz — 894MHz
UMTS900	890 MHz — 915MHz	925 MHz — 960 MHz
UMTS1900	1850 MHz — 1910 MHz	1930 MHz — 1990MHz
UMTS2100	1920 MHz — 1980 MHz	2110 MHz — 2170 MHz
GSM900	890 MHz — 915MHz	925 MHz — 960MHz



GSM1800	1710 MHz — 1785MHz	1805 MHz — 1880MHz
CDMA BC0	869 MHz — 894 MHz	824 MHz — 849 MHz
TD-SCDMA B34	2010~2025 MHz	2010~2025 MHz
TD-SCDMA B39	1880~1920 MHz	1880~1920 MHz
TDD_LTE B38	2570 MHz~2620 MHz	2570 MHz~2620 MHz
TDD_LTE B39	1880 MHz~1920 MHz	1880 MHz~1920 MHz
TDD_LTE B40	2300 MHz~2400 MHz	2300 MHz~2400 MHz
TDD_LTE B41	2555~2655 MHz	2555~2655 MHz
FDD_LTE B1	1920 MHz~1980 MHz	2110 MHz~2170 MHz
FDD_LTE B2	1850 MHz — 1910 MHz	1930 MHz — 1990MHz
FDD_LTE B3	1710 MHz~1785 MHz	1805 MHz~1880 MHz
FDD_LTE B4	1710 MHz~1755 MHz	2110 MHz~2155 MHz
FDD_LTE B5	824 MHz — 849MHz	869 MHz — 894MHz
FDD_LTE B7	2500 MHz~2570 MHz	2620 MHz~2690 MHz
FDD_LTE B8	880 MHz~915 MHz	925 MHz~960 MHz
FDD_LTE B12	699 MHz~716 MHz	729 MHz~746 MHz
FDD_LTE B13	777 MHz~787 MHz	746 MHz~756 MHz
FDD_LTE B17	704 MHz~716 MHz	734 MHz~746 MHz
FDD_LTE B20	832 MHz~862 MHz	791 MHz~821 MHz
GPS L1 BAND		1574.4 ~ 1576.44 MHz
GLONASS		1598 ~ 1606 MHz
BEIDOU B1		1559.05~1563.14 MHz

Table 2-4Conducted transmission power

Working Band	Max Power	Min Power
UMTS850	24dBm +1/-3dB	<-50dBm
UMTS900	24dBm +1/-3dB	<-50dBm
UMTS1900	24dBm +1/-3dB	<-50dBm
UMTS2100	24dBm +1/-3dB	<-50dBm
GSM900	33dBm ± 2dB	5dBm ± 5dB
DCS1800	30dBm ± 2dB	0dBm ± 5dB
GSM900(8-PSK)	27dBm ± 3dB	5dBm ± 5dB
DCS1800(8-PSK)	26dBm +3/-4dB	0dBm ± 5dB
CDMA BC0	24dBm +1/-3dB	<-50dBm
TD-SCDMA B34	24dBm +1/-3dB	<-50dBm
TD-SCDMA B39	24dBm +1/-3dB	<-50dBm
TDD_LTE B38	23dBm +/-2.7dB	<-40dBm
TDD_LTE B39	23dBm +/-2.7dB	<-40dBm
TDD_LTE B40	23dBm +/-2.7dB	<-40dBm

TDD_LTE B41	23dBm +/-2.7dB	<-40dBm
FDD_LTE B1	23dBm +/-2.7dB	<-40dBm
FDD_LTE B2	23dBm +/-2.7dB	<-40dBm
FDD_LTE B3	23dBm +/-2.7dB	<-40dBm
FDD_LTE B4	23dBm +/-2.7dB	<-40dBm
FDD_LTE B5	23dBm +/-2.7dB	<-40dBm
FDD_LTE B7	23dBm +/-2.7dB	<-40dBm
FDD_LTE B8	23dBm +/-2.7dB	<-40dBm
FDD_LTE B12	23dBm +/-2.7dB	<-40dBm
FDD_LTE B13	23dBm +/-2.7dB	<-40dBm
FDD_LTE B17	23dBm +/-2.7dB	<-40dBm
FDD_LTE B20	23dBm +/-2.7dB	<-40dBm

Table 2-5 Conducted receive sensitivity

Working Band	Receive sensitivity(Typical)	Receive sensitivity(MAX)
WCDMA B1	< -109dBm	3GPP
WCDMA B2	< -108dBm	3GPP
WCDMA B5	< -109dBm	3GPP
WCDMA B8	< -109dBm	3GPP
CDMA BC0	< -109dBm	3GPP
GSM900	< -109dBm	3GPP
DCS1800	< -108dBm	3GPP
TD-SCDMA B34	< -110dBm	3GPP
TD-SCDMA B39	< -110dBm	3GPP

Table 2-6 Reference sensitivity (QPSK)

Channel bandwidth							
E-UTRA Band	1.4 MHz	3 MHz	5 MHz	10 MHz	15 MHz	20 MHz	DuplexMode
1	--	--	-100	-97.2	-96.2	-95	FDD
2	-102.2	-99.7	-98	-95	-94.2	-93	FDD
3	-102.2	-99.7	-98	-95	-94.2	-93	FDD
4	-105.2	-101.7	-99	-96	-95.2	-96	FDD
5	-103.2	-101.7	-100.2	-97.2	--	--	FDD
7	--	--	-98	-95	-93.2	-92	FDD
8	-103.2	-101.7	-100.2	-97.2	--	--	FDD
12	-103.2	-101.7	-100.2	-97.2	--	--	FDD
13	--	--	-100.2	-97.2	--	--	FDD
17	--	--	-100.2	-97.2	--	--	FDD

20	--	--	-97	-94	-91.2	-90	FDD
38	--	--	-100	-97	-95.2	-94	TDD
39	--	--	-100	-97	-95.2	-94	TDD
40	--	--	-100	-97	-95.2	-94	TDD
41	--	--	-100	-97	-95.2	-94	TDD

LYNQ  
CONFIDENTIAL

## 3 Interface Description

### 3.1 PIN Definition

#### 3.1.1 Pin I/O parameter definition

The I/O parameter definition of the product is shown in table 3-1.

Table 3-1 I/O parameter definitions

Pin attribute symbol	Description
PI	Power input PIN
PO	Power output PIN
AI	Analog input
AIO	Analog signal input/output PIN
I/O	Digital signal input/output PIN
DI	Digital signal input
DO	Digital signal output
DOH	Digital output with high level
DOL	Digital output with low level
PD	Pull down
PU	Pull up
AO	Analog output

#### 3.1.2 Pin Map

L506 have different version, and the correspond pin definition show as special mark(\* mark or #mark) in the pin map. In the different hardware version the corresponding pin have differential using, detail description show as below chart. All hardware interfaces which connect L506 to customers' application platform are through 87 pinspads (Metal half hole). Figure 3-1 is L506 outline diagram.

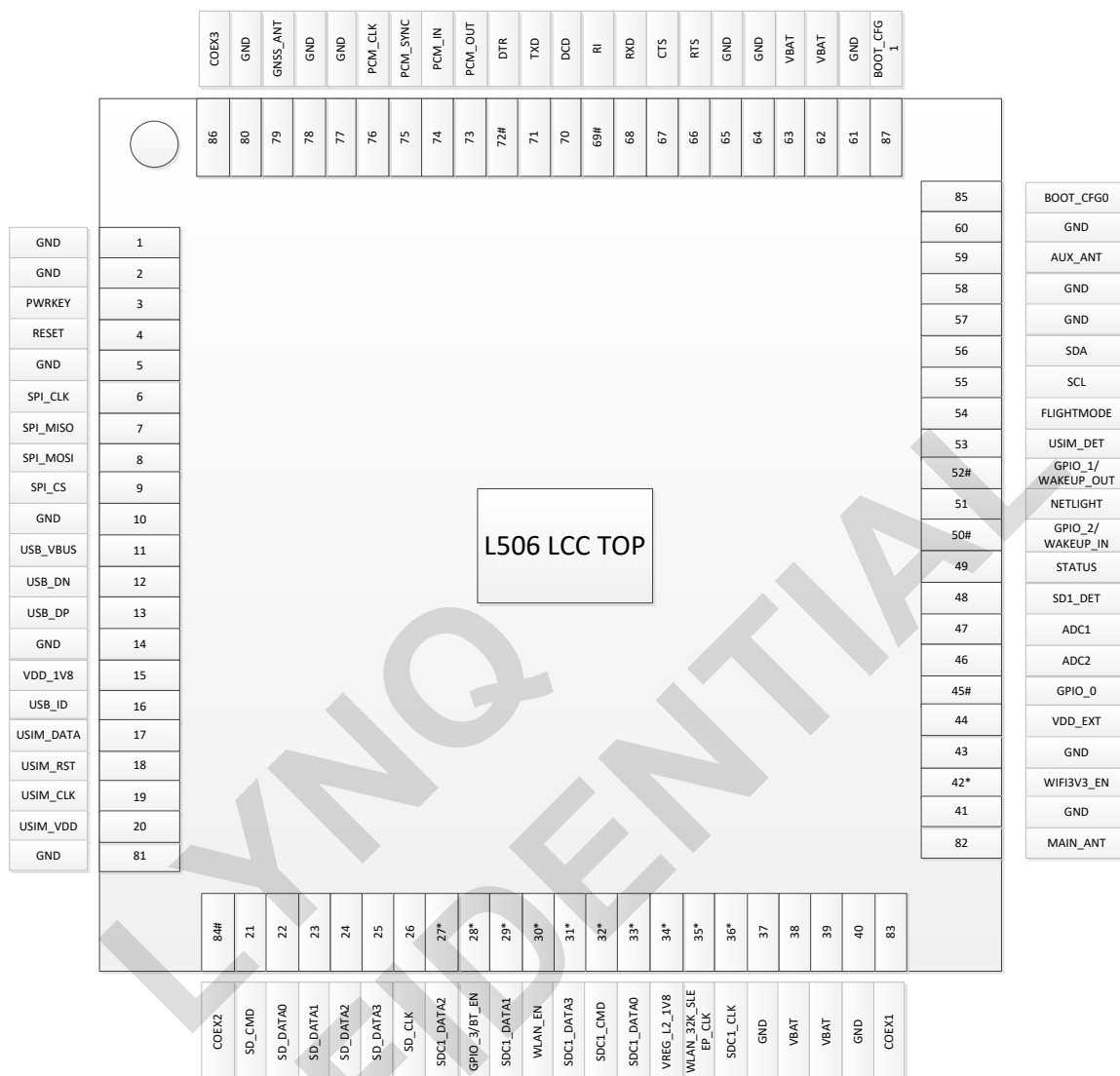

Figure 3-1 Pin Map View(Top View)

**Note:** 1.\* flag pin in Figure 3-1 stand for WIFI/BT interface in the WIFI edition module. In without WIFI interface edition, it's reserved pin,suggest in your design let the pin open.

2. #flag pin in Figure 3-1 stand for multi-function pin. Detail description show as in corresponding function description.

### 3.1.3 PIN Definition and function description

Table 3-2 Pin definition

Pin No.	Pin description	Pin No.	Pin description
1	GND	2	GND
3	PWRKEY	4	RESET
5	GND	6	SPI_CLK

7	SPI_MISO	8	SPI_MOSI
9	SPI_CS	10	GND
11	USB_VBUS	12	USB_DN
13	USB_DP	14	GND
15	VDD_1V8	16	USB_ID
17	USIM_DATA	18	USIM_RST
19	USIM_CLK	20	USIM_VDD
21	SD_CMD	22	SD_DATA0
23	SD_DATA1	24	SD_DATA2
25	SD_DATA3	26	SD_CLK
27*	SDC1_DATA2	28#	GPIO_3
29*	SDC1_DATA1	30*	WLAN_EN
31*	SDC1_DATA3	32*	SDC1_CMD
33*	SDC1_DATA0	34*	VREG_L2_1V8
35*	WLAN_32K_SLEEP_CLK	36*	SDC1_CLK
37	GND	38	VBAT
39	VBAT	40	GND
41	GND	42*	WIFI3V3_EN
43	GND	44	VDD_EXT
45#	GPIO_0	46	ADC2
47	ADC1	48	SD1_DET
49	STATUS	50#	GPIO_2/WAKEUP_IN
51	NETLIGHT	52#	GPIO_1/WAKEUP_OUT
53	USIM_DET	54	FLIGHTMODE
55	SCL	56	SDA
57	GND	58	GND
59	AUX_ANT	60	GND
61	GND	62	VBAT
63	VBAT	64	GND
65	GND	66	RTS
67	CTS	68	RXD
69#	RI	70	DCD

71	TXD	72#	DTR
73	PCM_OUT	74	PCM_IN
75	PCM_SYNC	76	PCM_CLK
77	GND	78	GND
79	GNSS_ANT	80	GND
81	GND	82	MAIN_ANT
83	COEX1	84	COEX2#
85	BOOT_CFG0	86	COEX3
87	BOOT_CFG1		

Table 3-3 Pin Function Description

Power interface				
Pin Name	Pin No.	I/O	Description	Content
VBAT	38, 39, 62, 63	PI	Power supply voltage, VBAT=3.4V~4.2V.	The power supply for system Maximum load current must above 2A.
VDD_1V8	15	PO	Module LDO output power, 1.8V output, Max current 150mA, For I/O, MCP, WLAN/BT, SLIC, sensors.	If not use keep it open.
VDD_EXT	44	PO	Module LDO output power, 2.85V output, Max current 300mA.	Only use for external SD Card VDD. If not use keep it open.
GND	1, 2, 5, 10, 14, 37, 40, 41, 43, 57, 58, 60, 61, 64, 65, 77, 78, 80, 81		Ground.	
System Control				
Pin Name	Pin No.	I/O	Description	Content
PWRKEY	3	DI	System power on/off input, active low.	
RESET	4	DI	System reset input, active low.	
FLIGHTMODE	54	DI, PU	The input signal, used to control the system into flight mode, H:	Pull UP to VDD_1V8 (PIN 15) with 10K resistor

			flight mode; L: normal mode	
Module status (GPIO)				
Pin Name	Pin No.	I/O	Description	Content
NETLIGHT	51	DO	Identify the system network status.	
STATUS	40	DO	Module status identify: High level power on, low level power off.	
WIFI/BT interface (WIFI Version)				
Pin name	Pin No.	I/O	Description	content
SD1_CMD	32	DO	SDIO command	WIFI SDIO, only WIFI version use, if not use keep it open.
SD1_DATA0	33	I/O	SDIO data	
SD1_DATA1	29	I/O	SDIO data	
SD1_DATA2	27	I/O	SDIO data	
SD1_DATA3	31	I/O	SDIO data	
SD1_CLK	36	DO	SDIO clock	
WLAN_EN	30	DO	WIFI module enable pin	
WIFI3V3_EN	42	DO	WIFI module power supply enable pin	If not use keep it open.
WLAN_32K_SLEEP_CLK	35	DO	WIFI module clock	If not use keep it open.
VREG_L2_1V8	34	PO	WIFI module 1.8V power supply	Only for WIFI use, if not use keep it open.
SD interface				
Pin Name	Pin No.	I/O	Description	Content
SD_CMD	21	DO	SDIO command	Advice add the ESD on you SD card Slot. If not use keep it open
SD_DATA0	22	I/O	SDIO data	
SD_DATA1	23	I/O	SDIO data	
SD_DATA2	24	I/O	SDIO data	
SD_DATA3	25	I/O	SDIO data	
SD_CLK	26	DO	SDIO clock	
SD_CARD_DET_N	48	DI, PU	Input pin as SD card detecting. H: SD card is removed L: SD card is inserted	L506 have internal pull up, so SD card slot should choose insert detect PIN connect the ground. If not use



				keep it open
GPIO_3/BT_EN	28	I/O	Default: GPIO Optional: BT_EN pin for ext bt module enable	If not use keep it open
<b>SIMinterface</b>				
Pin Name	Pin No.	I/O	Description	Content
USIM_DETECT	53	DI, PU	Input pin as USIM carddetect pin. H: USIM is removed L: USIM is inserted	L506 have internal pull up. If not use keep it open.
USIM_DATA	17	I/O	USIM Card data I/O, which has been pulled up with a 10KR resistor to USIM_VDD in module. Do not pull up or pull down in users' application circuit.	All signals of USIM interface should beprotected with ESD/EMC.
USIM_RESET	18	DO	USIM Reset	
USIM_CLK	19	DO	USIM Clock	
USIM_VDD	20	PO	USIM Card Power output, output Voltage depends on USIM mode automatically, and one is 3.0V±10%, another is 1.8V±10%. Current is less than 50mA.	
<b>PCM interface</b>				
Pin Name	Pin No.	I/O	Description	Content
PCM_CLK	76	DO	PCM data bit clock.	If not use keep it open.
PCM_SYNC	75	DO	PCM data frame sync signal.	
PCM_IN	74	DI	PCM data input.	
PCM_OUT	73	DO	PCM data output.	
<b>FULL UART/DEBUG PORT</b>				
Pin Name	Pin No.	I/O	Description	Content
RTS	66	DI	DET Request to send.	If not use keep it

				open.
CTS	67	DO	Clear to Send.	If not use keep it open.
RX	68	DI	Receive Data.	If not use keep it open.
RI	69#	DO	Ring Indicator.	Multiplexed as MDM_DBG_UART_TX. If not use keep it open. Recommend reserved the test point for debug
DCD	70	DO	Carrier detects.	If not use keep it open
TXD	71	DO	Transmit Data.	If not use keep it open.
DTR	72#	DI	DTE get ready.	Multiplexed as MDM_DBG_UART_RX. If not use keep it open. Recommend reserved the test point for debug
<b>I2C interface</b>				
Pin Name	Pin No.	I/O	Description	Content
I2C_SCL	55	DO	I2C clock output.	L506 internal have pulled up to 1.8V
I2C_SDA	56	I/O	I2C data input/output.	
<b>GPIO</b>				
Pin Name	Pin No.	I/O	Description	Content
GPIO_2/WAKEUP_IN	50	I/O	Default: GPIO Optional: Input pin as wake/interrupt signal to module from host.	If not use keep it open.
GPIO_1/WAKEUP_OUT	52	DO	Default: GPIO Optional: Output pin as wake/interrupt signal to host from module.	
GPIO_0	45	DO	Default: GPIO Optional: output control pin.	
RF port				

Pin Name	Pin No.	I/O	Description	Content
MAIN_ANT	82	AIO	Main Antenna	
AUX_ANT	59	AI	diversity antenna	
GNSS_ANT	79	AI	GPS antenna	
<b>Others</b>				
Pin Name	Pin No.	I/O	Description	Content
ADC1	47	AI	Analog conversion digital input interface1	If not use keep it open.
ADC2	46	AI	Analog conversion digital input interface2	
COEX1	83	I/O	RF synchronizing between wifi and	If not use keep it open. Normal use can't Pullup.
COEX3	86	I/O	LTE.	
COEX2	84#	I/O	Default: RF synchronizing between wifi and LTE. Optional: Pull up to 1.8V(L506 PIN 15 VDD_1V8)with 10K resistor force module in USB download mode	Recommend placing test points for debug. Normally can't Pullup.
BOOT_CFG0	85	DI, PD	Pull up to 1.8V(L506 PIN 15 VDD_1V8)with 10K resistor force module in fastboot mode	
BOOT_CFG1	87	DI, PD	Pull up to 1.8V(L506 PIN 15 VDD_1V8)with 10K resistor force module in fastboot mode	

## 3.2 Operating condition

Table 3-4 module recommended operating condition

Parameter	Description	Min.	Typ.	Max.	Unit
VBAT	Main power supply for	3.4	3.8	4.2	V

	the module				
--	------------	--	--	--	--

### 3.3 Digital I/O characteristics

Table 3-5 1.8V Digital I/O characteristics

Parameter	Description	Min.	Typ.	Max.	Unit
V <sub>IH</sub>	High level input voltage	0.7*VDD_PX	VDD_PX	VDD_PX+0.3	V
V <sub>IL</sub>	Low level input voltage	-0.3	0	0.2* VDD_PX	V
V <sub>OH</sub>	High level output voltage	VDD_PX-0.45	-	VDD_PX	V
V <sub>OL</sub>	Low level output voltage	0	0	0.45	V
I <sub>OH</sub>	High-level output current (nopull down resistor)	-	2	-	mA
I <sub>OL</sub>	Low-level output current (no pullup resistor)	-	-2	-	mA
I <sub>IH</sub>	Input high leakage current (no pull down resistor)	-	-	1	uA
I <sub>IL</sub>	Input low leakage current (nopull up resistor)	-1	-	-	uA

**\*Note: 1. These parameters are for digital interface pins, such as SPI, WIFI SDIO, GPIOs (NETLIGHT,**

**FLIGHTMODE, STATUS, USIM\_DET, SD1\_DET), I2C, UART, PCM, COEX<sub>n</sub>, BOOT\_CFG<sub>n</sub>.**

**2. L506 TF-card signal(SD\_DATA0~SD\_DATA3,SD\_CLK,SD\_CMD),USIM card**

**signal(USIM\_CLK,USIM\_DATA,USIM\_RST) support dual-voltage(1.8V and 3.0V)mode, and the DC character show in corresponding function block.**

### 3.4 Power Interface

#### 3.4.1 Power supply pin description

Table 3-6 DC Power Characteristics

Pin No.	Net Name	Description	DC Characteristic (V)		
			Min.	Typ.	Max.
38, 39, 62, 63	VBAT	Power supply for the module	3.4	3.8	4.2

1, 2, 5, 10, 14, 37, 40, 41, 43, 57, 58, 60, 61, 64, 65, 77, 78, 80, 81	GND	GND	-	-	-
44	VCC_EXT	Power supply for external SD card	-	2.85	-
20	USIM_VDD	Power supply for VDD SIM	-	1.8/3.0	-
15	VDD_1V8	LDO 1.8V output	-	1.8	-
88-99*	GND	Thermal and welding fixed plate	-	-	-

*Note: Pin88~Pin99 (total12pin) is design for the thermal welding fixed plate.*

### 3.4.2 Power supply requirements

There are four VBAT PIN power for the module, VBAT directly power supply for the module baseband and PA, and operating rating is 3.4V~4.2V; In the weak network environment, the antenna will be maximum power emission. The peak current of the module under the 2G mode may reach the peak current of 1.8A. power supply to reach 2A, the average current to reach 0.9A above. Due to the launch of GSM/GPRS time slot pulse can cause VBAT power source instantaneous voltage drop, maximum peak current can reach 2A, So the max power supply current must more than 2 A. Figure 3-2 sign for GSM/GPRS instantaneous pulse diagram.

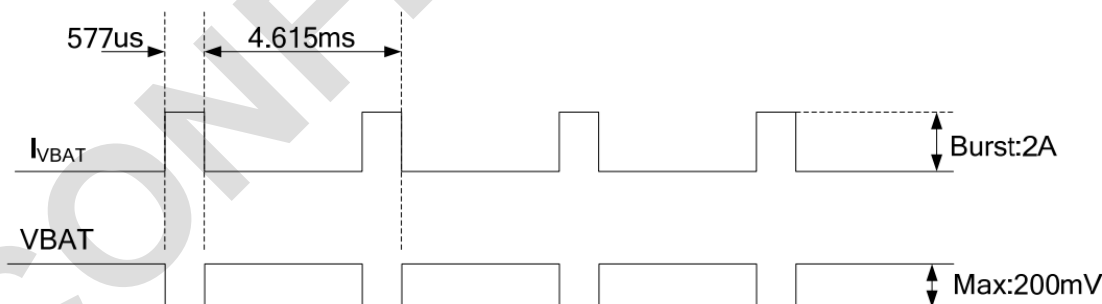

Figure 3-2 GSM/GPRS instantaneous pulse

Table 3-7 VBAT power supply interface characteristics

Symbol	Description	Min	Typ	Max	Unit
VBAT	Power supply voltage	3.4	3.8	4.2	V
I <sub>VBAT</sub> (peak)	Power supply p	-	2*	-	A

	current				
IVBAT (average)	Power supply average current	1	1.5	-	A
IVBAT (power-off)	Power supply current in power off mode	-	-	20	uA
IVBAT (power-save)	Power supply current in power save mode (sleep mode)	-	-	3	mA

### 3.4.3 Power Supply Design Guide

Make sure that the input voltage at the VBAT pin will never drop below 3.4V even during a transmit burst when the current consumption rises up to more than 2A. If the power voltage drops below 3.4V, the RF performance of module may be affected. Using large tantalum capacitors (above 300uF) will be the best way to reduce the voltage drops. If the power current cannot support up to 2A, users must introduce larger capacitor (typical 1000uF) to storage electric power. For the consideration of RF performance and system stability, some multi-layer ceramic chip (MLCC) capacitors (0.1/1uF) need to be used for EMC because of their low ESR in high frequencies. Note that capacitors should be put beside VBAT pins as close as possible. Also User should keep VBAT net wider than 2 mm to minimize PCB trace impedance on circuit board. The following figure is the recommended circuit.

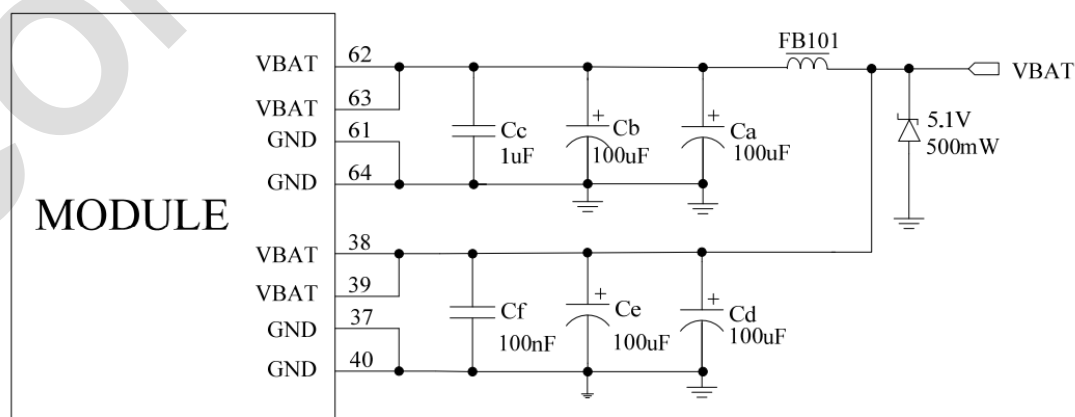

Figure 3-3 VBAT input application circuit

**Note:** The Cd, Ce, Cb, Cc and Cf are recommended being mounted for L506, but the Ca, Cb, Ce, Cc and Cf for tune.

In addition, in order to get a stable power source, it is suggested to use a Zener diode of which reverse Zener voltage is 5.1V and dissipation power is more than 500mW.

Table 3-8: Recommended Zener diode models

NO.	Manufacturer	Part Number	Power	Package
1	On semi	MMSZ5231BT1G	500mW	SOD123
2	Prisemi	PZ3D4V2H	500mW	SOD123
3	Vishay	MMSZ4689-V	500mW	SOD123
4	Crownpo	CDZ55C5V1SM	500mW	0805

### 3.4.4 Recommended Power supply circuit

If the voltage difference is not big, We recommend DCDC or LDO is used for the power supply of the module, make sure that the peak current of power components can rise up to more than 2A. The following figure is the reference design of +5V input linear regulator power supply. The designed output for the power supply is 3.8V.

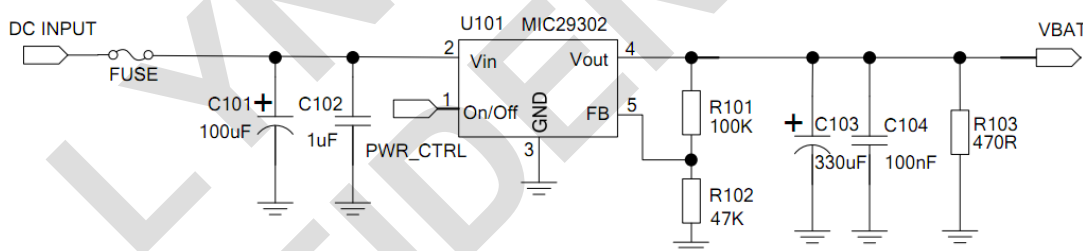

Figure 3-4 Reference circuit of the LDO power supply

If there is a big difference between the input voltage and the desired output (VBAT) or better efficiency is more important, a switching converter power supply will be preferable. The following figure is the reference circuit.

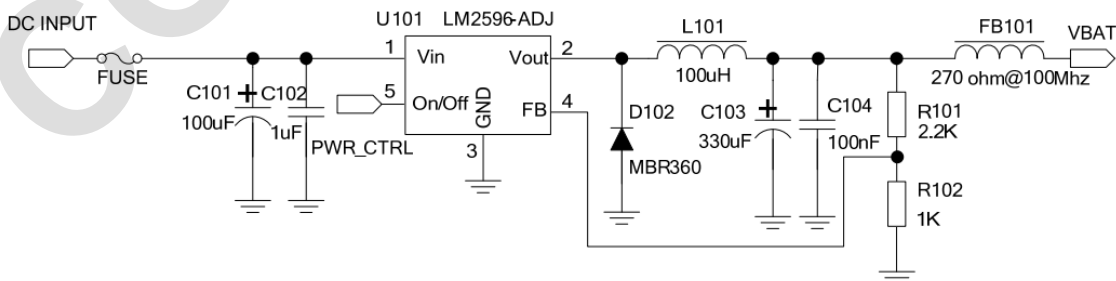

Figure 3-5 Reference circuit of the DCDC power supply

Note: DCDC may deprave RF performance because of ripple current intrinsically.

### 3.4.5 Power Supply Layout guide

The layout of the power supply section and the related components is of vital importance in the power module design. If processes this part layout is not good, will lead to various effects, such as bad EMC, effective the emission spectrum and receiving sensitivity, etc. So the power supply part design is very important, when you design this part you should notes below contents: 1. DC DC switch power should place away from the antenna and other sensitivity circuit; 2. Consider the voltage drop and the module current requirement, the layout line should better above 100mil. If conditions allow should add a power shape plane.

## 3.5 USIM interface

### 3.5.1 Pin definition

The L506 integrated a ISO 7816-2 standard USIM port, and the module can automatic identify the voltage demo according the USIM to allow the mobile equipment toattach to the network. Both 1.8V and 3.0V SIM Cards are supported.

Table 3-9USIM Electronic characteristic in 1.8V mode (USIM\_VDD =1.8V)

Symbol	Parameter	Min.	Typ.	Max.	Unit
USIM_VDD	LDO power output	1.75	1.8	1.95	V
V <sub>IH</sub>	High-level input voltage	0.65·USI M_VDD	–	USIM_V DD +0.3	V
V <sub>IL</sub>	Low-level input voltage	-0.3	0	0.35·USI M_VDD	V
V <sub>OH</sub>	High-level output voltage	USIM_V DD -0.45	–	USIM_V DD	V
V <sub>OL</sub>	Low-level output voltage	0	0	0.45	V

Table 3-10: USIM Electronic characteristic 3.0V mode (USIM\_VDD =3.0V)

Symbol	Parameter	Min.	Typ.	Max.	Unit
USIM_VDD	LDO power output	2.75	3.0	3.05	V
V <sub>IH</sub>	High-level input voltage	0.65*USI M_VDD	–	USIM_V DD +0.3	V
V <sub>IL</sub>	Low-level input voltage	-0.3	0	0.25·USI M_VDD	V
V <sub>OH</sub>	High-level output voltage	USIM_V DD -0.45	–	USIM_V DD	V
V <sub>OL</sub>	Low-level output voltage	0	0	0.45	V



### 3.5.2 Design Guide

USIM electronic characteristics as the table 3-8,3-9 show.

In order to meet the 3 GPP TS 51.010 1 protocol and EMC certification requirements. Suggest USIM slot near the location of the module USIM card interface, to avoid running for too long, lead to serious deformation of waveform and effect signal integrity, USIM\_CLK and USIM\_DATA signal lines suggest ground protect. Between the USIM VCC & GND add a 1uF and a 33 pF capacitor in parallel, Between the USIM\_CLK& GND, USIM\_RST& GND, USIM DATA& GND add a 33 pF capacitor in parallel, for filter the RF signal interference.

### 3.5.3 USIM interface reference circuit

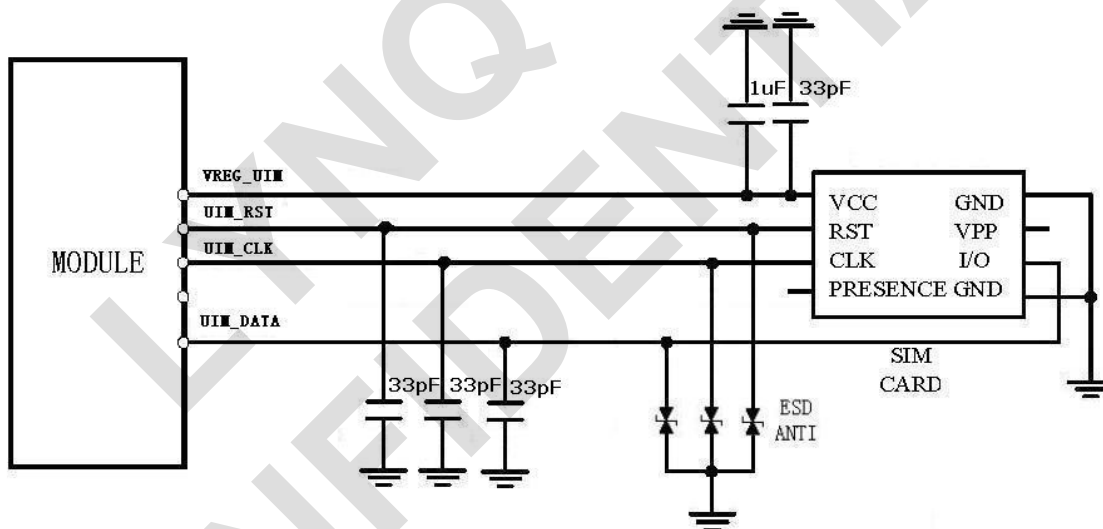

Figure 3-6 USIM Reference circuit

Note:1.USIM\_DATA have added the pull-up resistance in the module design.

2. L506 support hot-plug detect, if need the function, please add this pin.

## 3.6 PCM interface

### 3.6.1 PCM interface definition

L506 provides hardware PCM interface for external codec. L506 PCM interface can be used in short sync master mode only, and only supports 16 bits linear format:

Table 3-11 PCM interface definition

Pin No.	Signal name	I/O Type	DC Characteristics (V)		
			Min.	Typ.	Max.
75	PCM_SYNC	PCM synchronizing signal	-0.3	1.8	1.9
74	PCM_DIN	PCM data input	-0.3	1.8	1.9
73	PCM_DOUT	PCM Data output	-0.3	1.8	1.9
76	PCM_CLK	PCM Data clock	-0.3	1.8	1.9

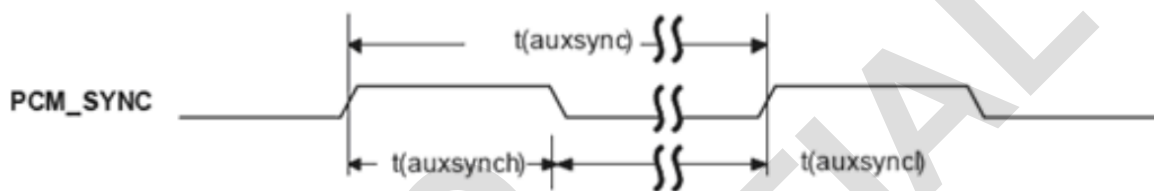

Figure 3-7 PCM\_SYNC timing

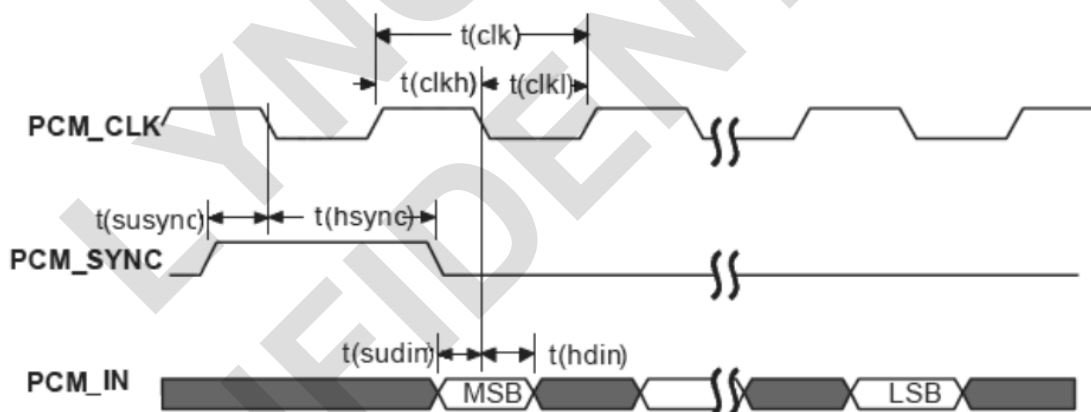

Figure 3-8 Codec to L506 module timing

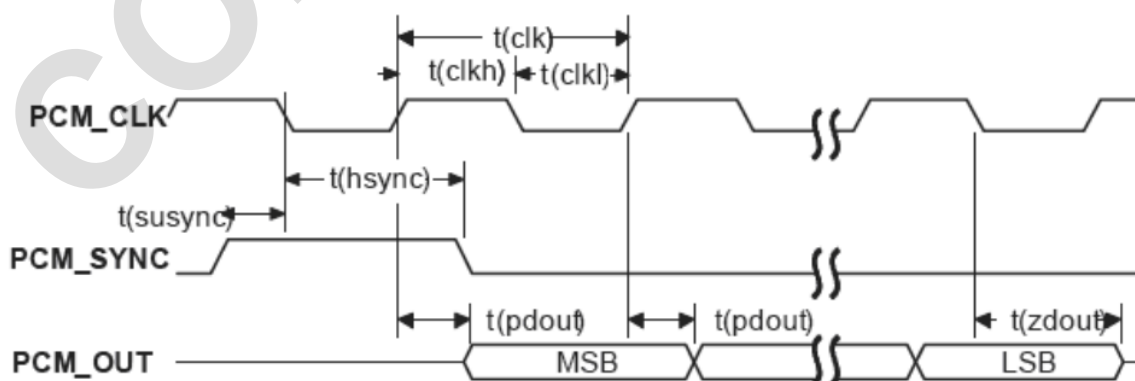

Figure 3-9 L506 to codec module timing

Table 3-12 PCM interface Timing

Parameter	Descriptions	DC characters			
		Min.	Typ.	Max.	Unit
T(sync)	PCM_SYNC cycle	-	125	-	us
T(synch)	PCM_SYNC high level hold time	-	488	-	ns
T(sync1)	PCM_SYNC low level hold time	-	124.5	-	us
T(clk)	PCM_CLK cycle	-	488	-	ns
T(clkh)	PCM_CLK high level hold time	-	244	-	ns
T(clkl)	PCM_CLK low level hold time	-	244	-	ns
T(susync)	PCM_SYNC establish time	-	122	-	ns
T(hsync)	PCM_SYNC hold time	-	366	-	ns
T(sudin)	PCM_IN establish time	60	-	-	ns
T(hdin)	PCM_IN hold time	60	-	-	ns
T(pdout)	From PCM_CLK rising edge to PCM_OUTvalid time	-	-	60	ns
T(zdout)	From PCM_CLK falling edge to PCM_OUT high impendence delay time	-	-	60	ns

### 3.6.2 PCM interface application

L506 only support the host mode, PCM\_SYNC, PCM\_CLK is the output pin, PCM\_SYN as the synchronizing output 8kHz sync signal. PCM Data support 8bit or 16bit data.

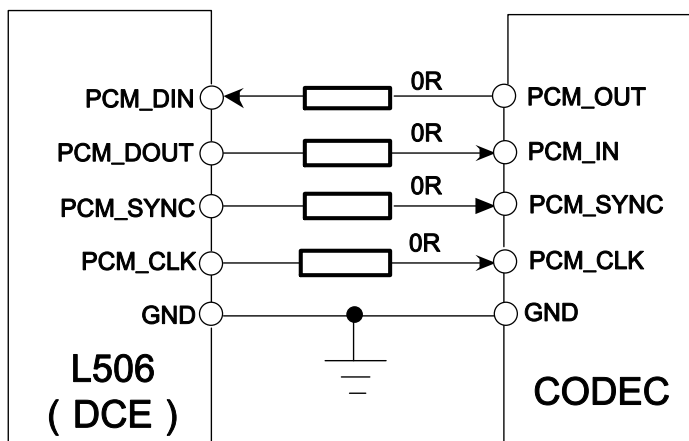

Figure 3-10 PCM application circuit (L506 in host mode)

**Note:1.L506 PCM port DC character is base on 1.8 voltage, please pay attention the voltage matching.**

**2. If your design need this function, you should add the crystal for PCM clock. About the crystal type please contact our market.**

**3. L506 default design base on NAU8814 as the codec chip, the detail design please refer to 《L506 reference design》.**

## 3.7 USB2.0 interface

### 3.7.1 USB interface pin definition

L506 integrated a USB 2.0 port and low speed mode full speed mode and high speed mode transmission speed between the AP and the host. Below table is the module USB pin definition

Table 3-13 USB interface pin definition

Pin No.	Signal name	I/O type	DC characteristic (V)		
			Min.	Typ.	Max.
12	USB_DM	USB2.0 dataD-	-	-	-
13	USB_DP	USB2.0 data D+	-	-	-

### 3.7.2 USB Interface application

USB bus is mainly used for data transmission, software upgrading, module testing. Work in the high-speed mode of the USB line, if you need ESD design, ESD protection device must meet the junction capacitance value  $<5\text{pf}$ , otherwise the larger junction capacitance will cause waveform

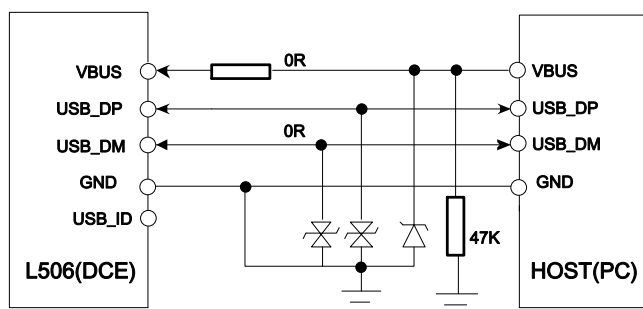

distortion, the impact of bus communication. Differential impedance of differential data line in  $90\text{ohm} + 10\%$ . In your application must add a  $47\text{Kohm}$  resistor between USB\_VBUS to ground.

Figure 3-11 USB application

## 3.8 UART Interface

### 3.8.1 Pin description

L506 module provides a flexible 7-wire UART (universal asynchronous serial transmission) interface. UART as a full asynchronous communication interface, Support the standard modem handshake signal control, Comply with the RS - 232 interface protocols. And also support four wire serial bus interface or the 2-wire serial bus interface mode, and the module can be through the UART interface for serial communication with the outside (DET) and the AT command input, etc. L506 module is a DCE (Data Communication Equipment) and client PC is a DTE (Data Terminal Equipment). AT commands are entered and serial communication is performed through UART interface. The pin signal is defined as shown in below table.

Table 3-14 UART pin definition

Pin No.	Pin	I/O type	Descriptions
71	UART_TX	DO	UART data transmission
68	UART_RX	DI	UART data receive
69	UART_RI	DO	Ring Indicator.
66	UART_RTS	DO	UARTDET request to send
72	UART_DTR	DI	DTE get ready.

67	UART_CTS	DI	UART Clear to Send.
70	UART_DCD	DO	UART Carrier detects.

**Note :** *UART\_RI, UART\_DTR can be used as two line UART interface for system debugging, See table 3-3 Pin functional description.*

### 3.8.2 UART interface application

UART\_RI, UART\_DTR default status is the system log port, so we recommend that users keep reserved the interface and test points in design. The L506 UART is 1.8V interface. A level shifter should be used if user's application is equipped with a 3.3V UART interface. The level shifter TXB0108RGYR provided by Texas Instruments is recommended. The reference design of the TXB0108RGYR is in the following figures. About the application as below:

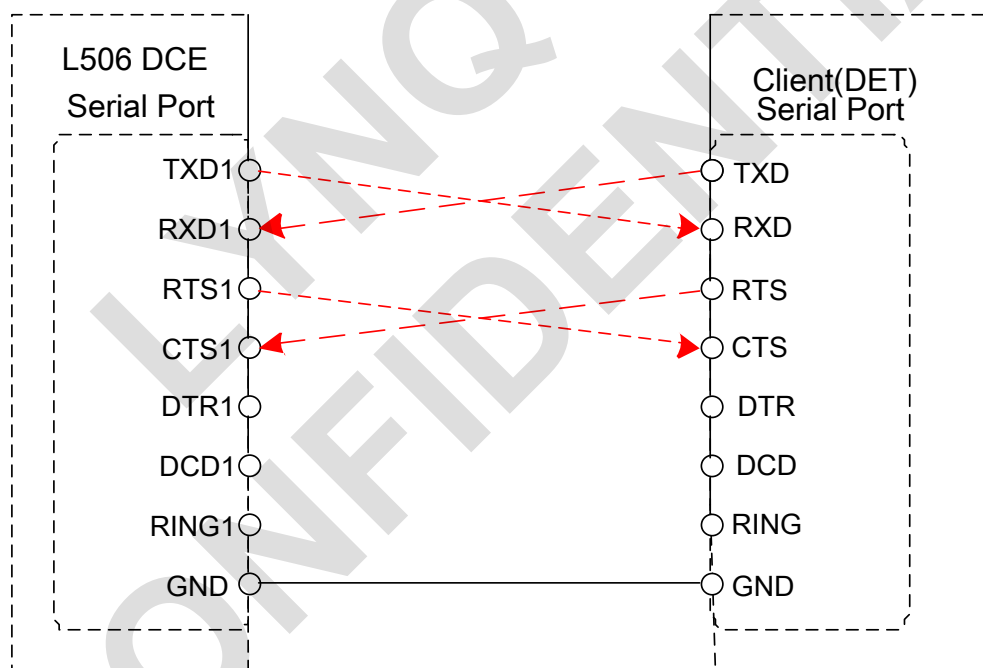

Figure 3-12 UART 4 Line connection mode

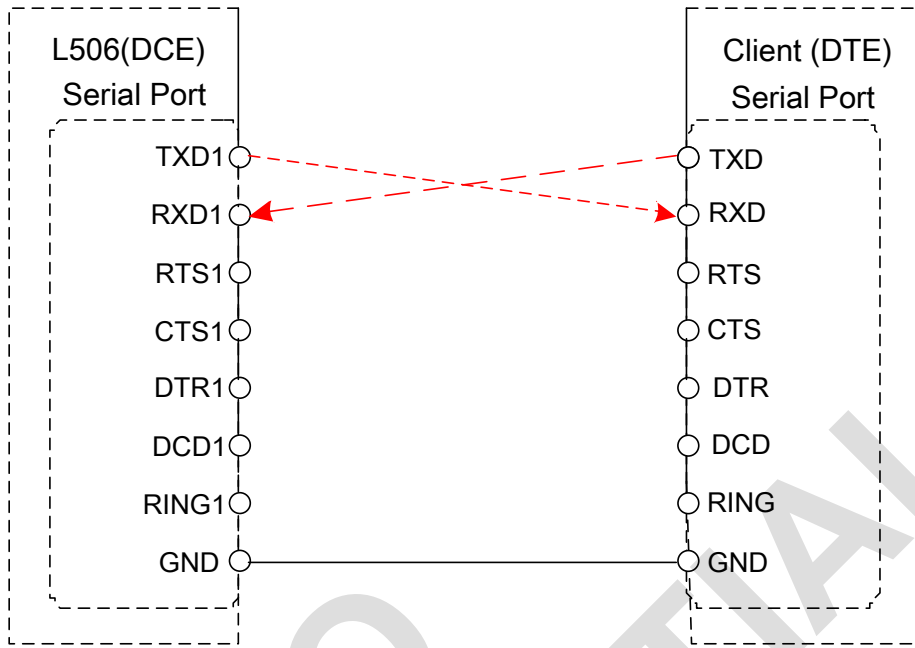

Figure 3-13UART 2 Line connection mode

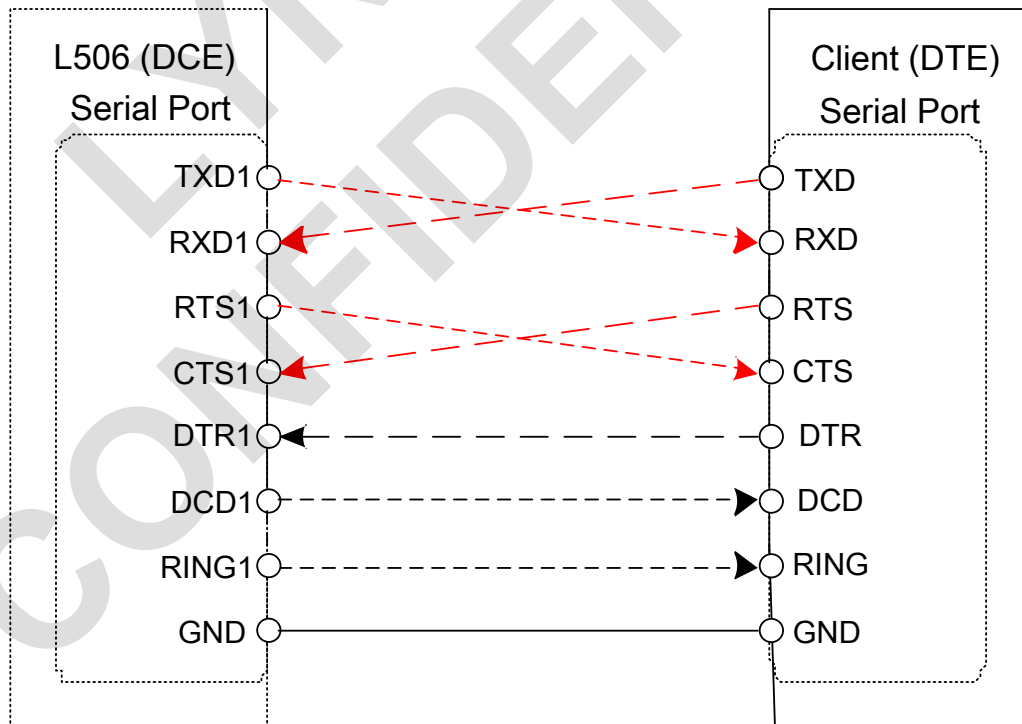

Figure 3-14UART Full mode

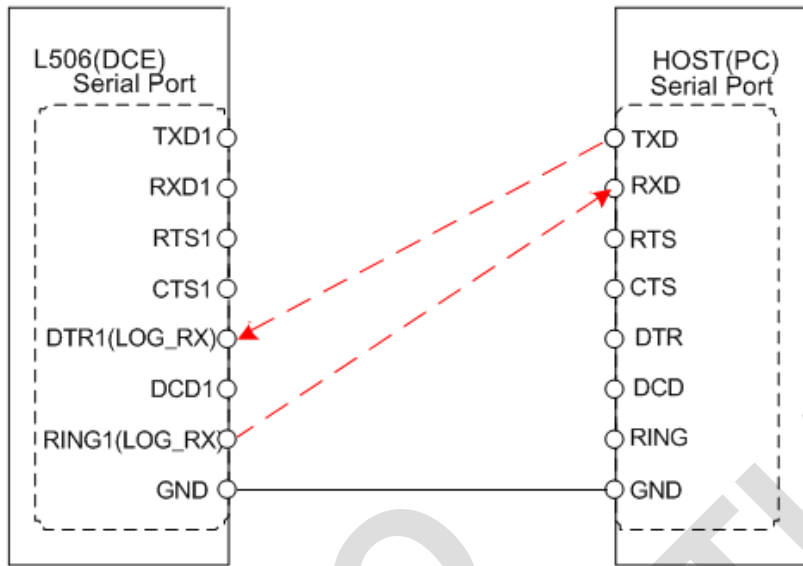
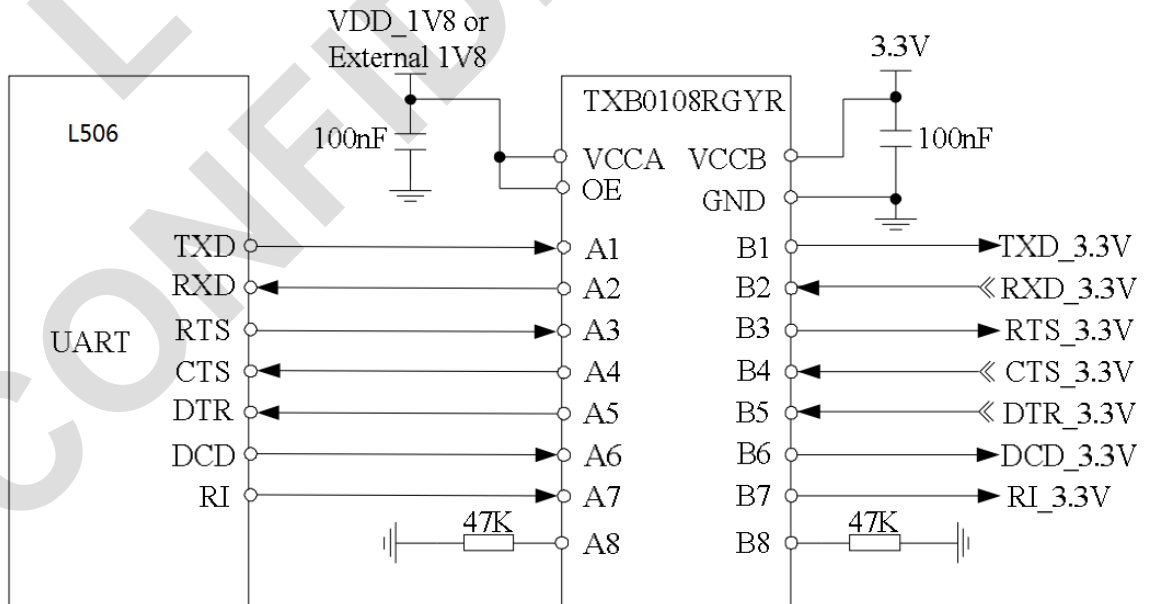

Figure 3-15 UART in debug mode

L506 UART is COMS 1.8V level, if the AP voltage level is not the 1.8V should add a voltage transfer module in your application. Below is SP3238E application diagram.



Figures 3-16 Voltage transfer Reference Circuit



## 3.9 Power on/off and reset interface

### 3.9.1 Pin definition

L506 can be powered on by pulling PWRKEY pin down to ground. This pin is already internal pulled up to 1.8V in module, so external pull-up resistor is not necessary. Placing a 100nF capacitor and an ESD protection diode close to the PWRKEY pin is strongly recommended. Please refer to the following figure for recommended reference circuit. L506 also has a RESET pin to reset module. This function is used as an emergency reset only when AT command “AT+CPOF” and the PWRKEY pin has no effect. User can pull RESET pin to ground, then module will reset. This pin is already pulled up with a 40K $\Omega$  resistor to 1.8V in module, so external pull-up resistor is not necessary. Placing a 100nF capacitor and an ESD protection diode close to the RESET pin is strongly recommended. Please refer to the following figure for recommended reference circuit, you can pull-down this pin to ground and hold about 200 MS and then release will force the module enter reset state.

Table 3-15 power on/off and reset key define

Pin No.	Net name	I/O Typ.	descriptions
3	PWRKEY	DI	L506 power on/off pin (internal pull-up to 1.8V)
4	RESET	DI	L506 RESET pin (internal pull-up to 1.8V)

### 3.9.2 Power on sequence

Table 3-16 power on timing chart.

Ton	Power on low level pulse	100	500	--	ms
Ton(status)	Power on time (According to the STATUS pin judgment)	15	--	25	s
Ton(uart)	Power on time (according the UART pin judgement)	10	--	20	s
V <sub>IH</sub>	Input high level voltage of PWRKEY pin	1.17	1.8	2.1	V
V <sub>IL</sub>	Input low level voltage of PWRKEY pin	-0.3	0	0.3	V

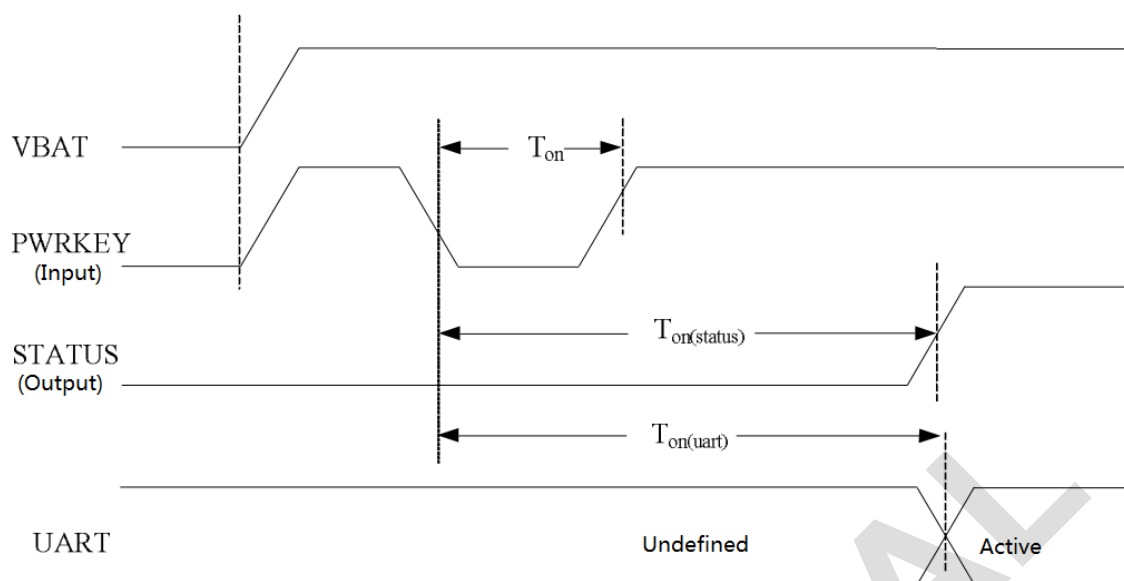

Figures 3-17 Power on Timing sequence

**Note:** the STATUS pin can be used to identify whether has been power on, when the module has access to electricity and initialization is completed, the STATUS output high level, or has maintained low level.

### 3.9.3 Power off sequence

The following methods can be used to power down. These procedures will make module disconnect from the network and allow the software to enter a safe state, and then save data before completely powering the module off.

- Method 1: Power off L506 by pulling the PWRKEY pin down
- Method 2: Power off L506 by AT command “AT+CPOF”
- Method 3: over-voltage or under-voltage automatic power down.
- Method 4: over-temperature or under-temperature automatic power down.

Note: 1. About the AT command “AT+CPOF” detail please refer document [1].

**2. Over-voltage or under-voltage may cause automatic power down.**

**3. Over-temperature or under-temperature may cause automatic power down.**

Table 3-17 Power off timing chart.

$T_{off}$	The time of active low level pulse on PWRKEY pin to power off module	2.5	--	--	s
$T_{off(status)}$	The time from power-off issue to STATUS pin output low level (indicating power off)	6	--	--	s
$T_{off(uart)}$	The time from power-off issue to UART port off	6	--	--	s
$T_{off-on}$	The buffer time from power-off issue to power-on issue	0	--	--	V

V <sub>IH</sub>	Input high level voltage of PWRKEY pin	1.17	1.8	2.1	V
V <sub>IL</sub>	Input low level voltage of PWRKEY pin	-0.3	0	0.3	V

User can power off the L506 by pulling PWRKEY down to ground for a specific time. The power off scenario is illustrated in the following figure.

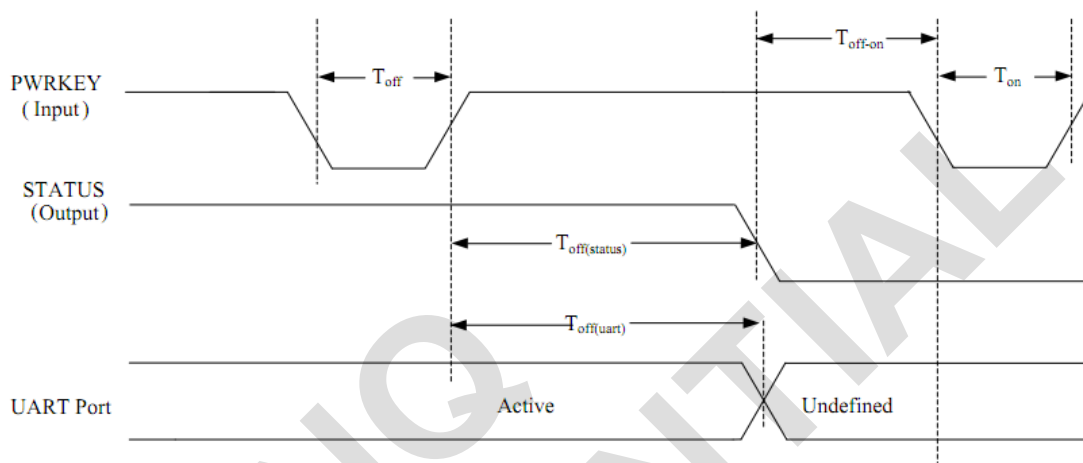

Figures 3-18 Power off Timing sequence

**Note:** the STATUS pin can be used to identify whether has been power on, when the module has access to electricity and initialization is completed, the STATUS output high level, or has maintained low level.

### 3.9.4 Reset sequence

L506 can lower module RESET pin to restart the module.

Table 3-18 Reset pin electrical properties

Symbol	Net name	Min.	Typ.	Max.	Unit
Treset	Reset pin low level hold time	50	100	500	ms
V <sub>IH</sub>	Reset pin input high level	1.17	1.8	2.1	V
V <sub>IL</sub>	Reset pin input low level	-0.3	0	0.3	V

**Note:** it is recommended that only in an emergency, such as module without response, use the RESET pin. In addition, under the module power off status the RESET pin is invalid.

### 3.9.5 Power on/off and reset interface application

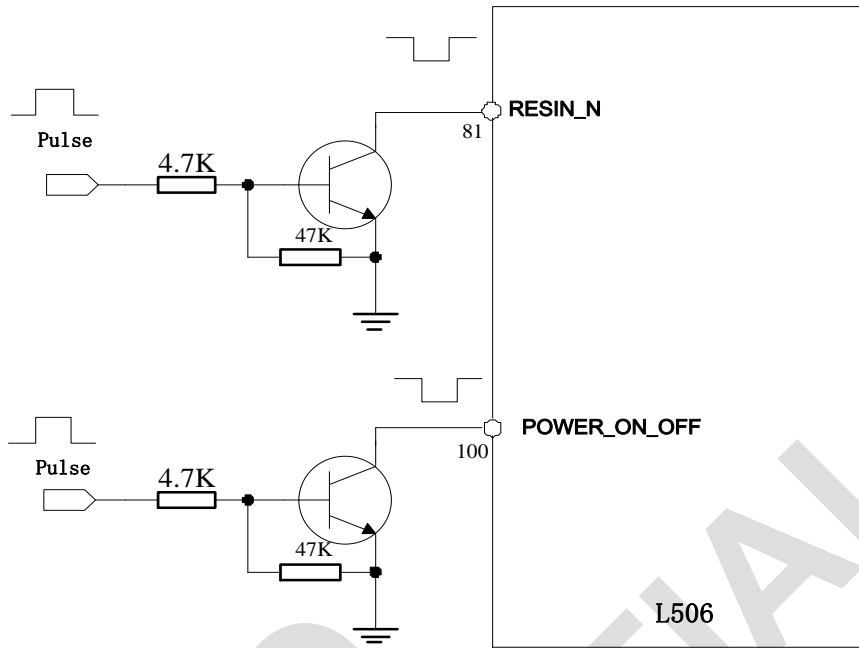

Figure 3-19: Reference power on/off reset circuit

Another way to control the PWRKEY pin is directly using a push button switch. Need to set a button near the TVS to ESD protection. The image below for reference circuit:

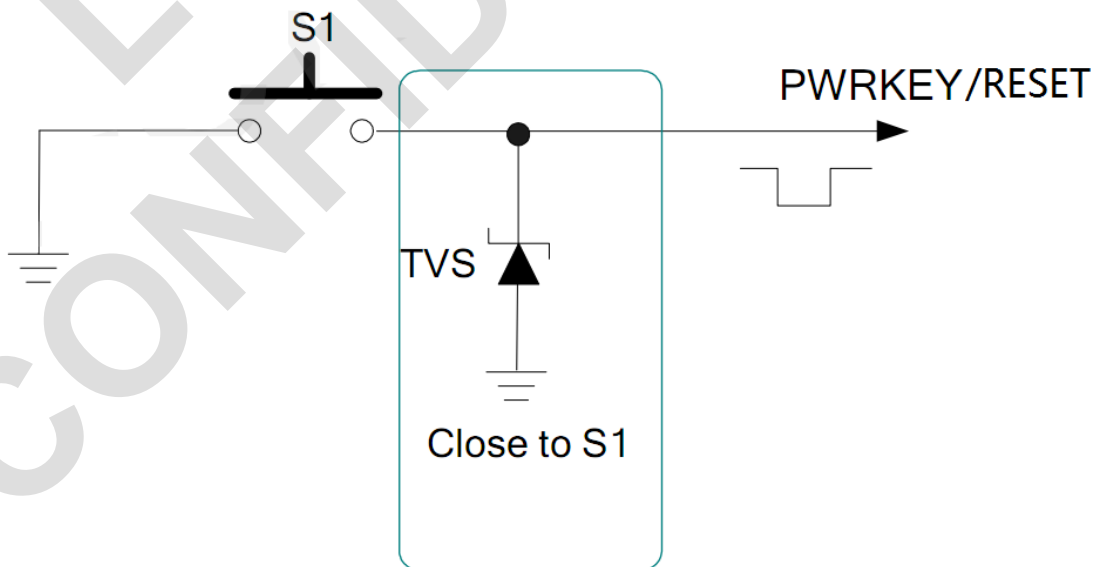

Figure 3-20: power on/off and reset recommended circuit (physical buttons)

## 3.10 Interactive interface

### 3.10.1 Pin definition

Table 3-19 list the interface is mainly with the application processor interactive interface, including query, wake up four types, status indication, flight mode interface.

Table3-19Interactive interface

Pin No.	Signal	I/O type	Descriptions
50	GPIO_2/WAKEUP_IN	DI	Default: GPIO Optional: Input pin as wake up interrupt signal to module from host.
52	GPIO_1/WAKEUP_OUT		Default:GPIO Optional: Output pin as the module wake up the AP
49	STATUS	DO	APinquire the module status
54	FLGHTMODE	DI	Pull up to 1.8V made the system enter in flight mode, at this mode will tune off all the wireless function
45	GPIO_0	DO	General GPIO module output (used for keyboard backlighting, etc.)
28	GPIO_3	I/O	GPIO

### 3.10.2 interactive interface application

L506 provides three shook hands with application processor communication signals. Application processor can query whether the module boot normal work through STATUS. Through the WAKEUP\_OUT query module is in sleep mode, and sleep in the module, through WAKEUP\_IN wake module. Similarly, when application processor in the sleep state, the L506 modules can through WAKEUP\_OUT wake application processor.

- STATUS: Module sleep instructions, high level indicator to sleep, low level instructions for the awakened state;
- WAKEUP\_IN: The host can lower the signal awakens the module, If, low level has maintained, module can't sleep.
- WAKEUP\_OUT: when L506 need to communicate with the AP, module can be set this pin for low level to awaken application processor.
- FLGHTMODE: Through the external output high level module into flight mode;

FLIGHTMODE pin can be used to control module to enter or exit the flight mode. In flight mode, L506 internal radio frequency circuit is closed. FLIGHTMODE reference circuit as shown in the figure below:

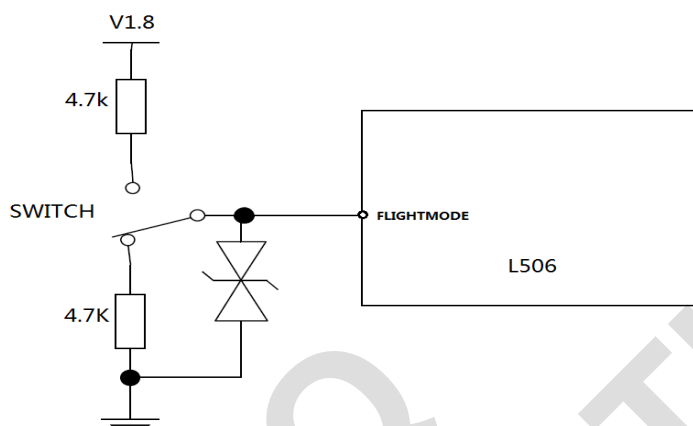

Figure 3-21:Flight mode recommended circuit (physical buttons)

## 3.11 Net Light interface

### 3.11.1 Pin define

Table 3-20 LED pin definitions

Pin No.	Net name	I/Otype	description
51	NETLIGHT	DO	Module net state identify control LED port

### 3.11.2 Net light application

The L506 module has 1 pins for controlling the LED display, which can be used as an indicator of network connection status. Different network states are represented by the mode of the flashing light. This pin is an GPIO, with An external NPN Transistor, External connect VBAT can directly drive LED. Drive current capacity varies according to external NPN model , recommend use DTC143ZEBTL, Drive current biggest can reach 100 mA, below is the reference circuit.

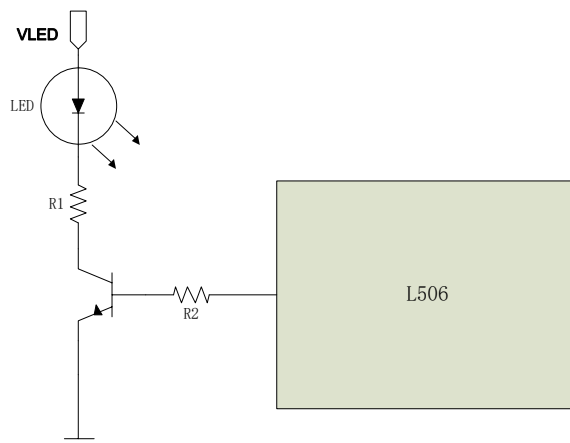

Figure 3-22 Status indicator reference circuit

Note: R1, R2 value according to the voltage VLED and LED working current.

Table 3-21 NETLIGHT status

Net Status	Module working status
Always on	Searching Network/Call Connect
200ms ON, 200ms OFF	Data Transmit
800ms ON, 800ms OFF	Registered network
OFF	Power off / Sleep

Note: NETLIGHT output low level as “ON”, and high level as “OFF”.

## 3.12 SD card interface

### 3.12.1 Pin descriptions

L506 provides a 4-bit SD/MMC interface with clock rate up to 52MHz. The operation voltage of MMC/SD interface is 2.85V with SD/MMC memory cards up to 128G(FAT4), which is compatible with SDIO Card Specification (version 3.0), Secure Digital (Physical Layer Specification, version 3.0) and Multimedia Card Host Specification MMC (version 4.4)

Table 3-22 SD characteristics

Symbol	Parameter	Min.	Typ.	Max.	Unit
VDD_EXT**	LDO output	-	2.85	-	V
VIH	High-level input voltage	0.625*VDD_EXT	-	VDD_EXT+0.3	V
VIL	Low-level input voltage	-0.3	0	0.25*VDD_EXT	V

VOH	High-level output voltage	$2.75 * V_{DD\_E\_XT}$	2.85	V
VOL	Low-level output voltage	0	0	V

SD card I/O load capacity for linear output displacement, concrete can be calculated according to the following chart;

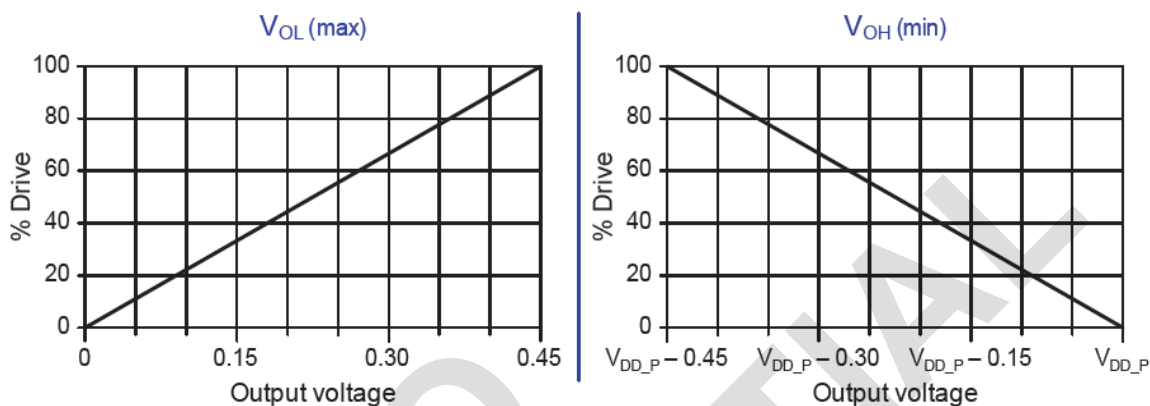

Figure 3-23 VOL/VOH IV curve

### 3.12.2 SD card interface design guideline

L506 VDD\_EXT for external SD card interface of power supply, in the card slot position should add the ESD protection circuit; If you need to support SD hot plug design need to add SD\_DET signals. Due to the default hot plug pin of L506 check for low level to identify the card insert status, so you need to choose the detect PIN connected to the ground when SD card is inserted into the SD slot, below is the reference circuit.

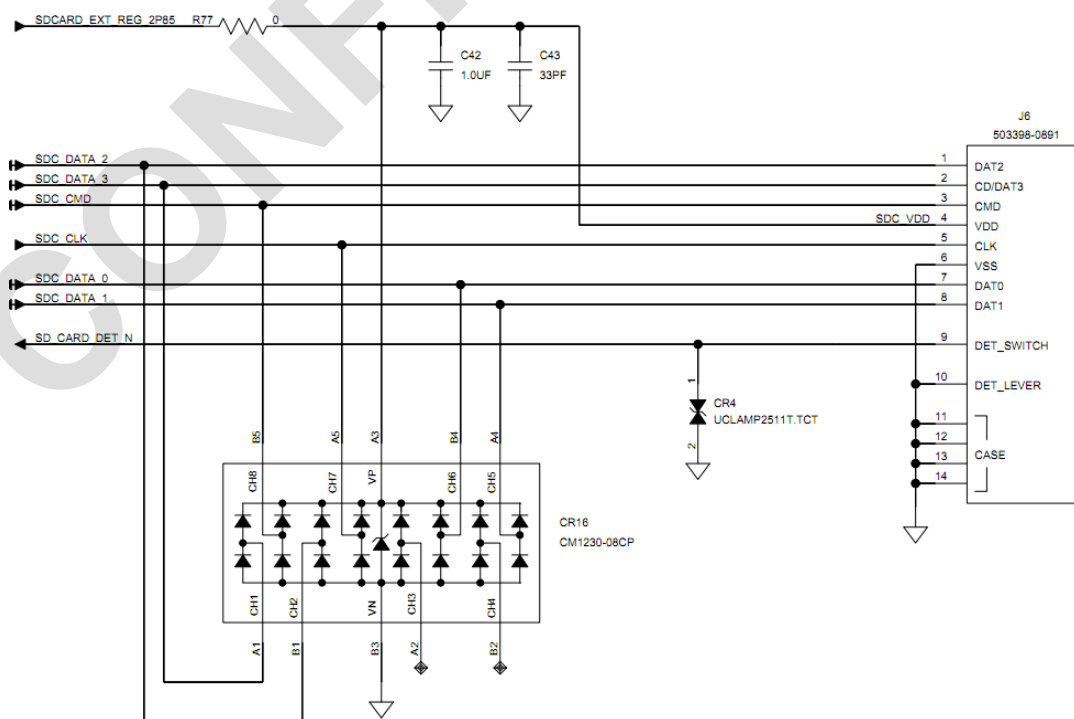

Figure 3-24SD card recommended circuit



### 3.12.3 SD card signal PCB line rules

Due to the SD signal is the high-speed digital interface, so it's layout rules should be in accordance with the high speed digital rules.

1. Protect other sensitive signals/circuits from SDC corruption.
2. Protect SDC signals from noisy signals (clocks, SMPS, etc.).
3. 50  $\Omega$  nominal,  $\pm 10\%$  trace impedance.
4. CLK to DATA/CMD length matching < 1 mm.
5. Total routing length < 50 mm recommended.
6. Spacing to all other signals = 2x line width. 6 Bus capacitance < 15 pF.

## 3.13 System boot configuration and download

### 3.13.1 Pin definition

L506 can configure BOOT\_CONFIG (Boot Configuration) pin to Configuration module power-on mode and the forced entry USB download mode.

**BOOT CONFIGURATION TABLE**

BOOT_CONFIG[3:1]	BOOT OPTIONS
0b000	NAND → USB
0b001	Only USB

Table 3-23 Boot configuration and force USB download

Pin No.	Net name	Function description	note
85	BOOT_CFG0	Pull up this pin change boot configuration register value	
87	BOOT_CFG1	Pull up this pin change boot configuration register value	
84	COEX2 (System on)	FOCE_USB_BOOT (before system on)	Multiplex pin

### 3.13.2 Boot configuration and force USB interface application

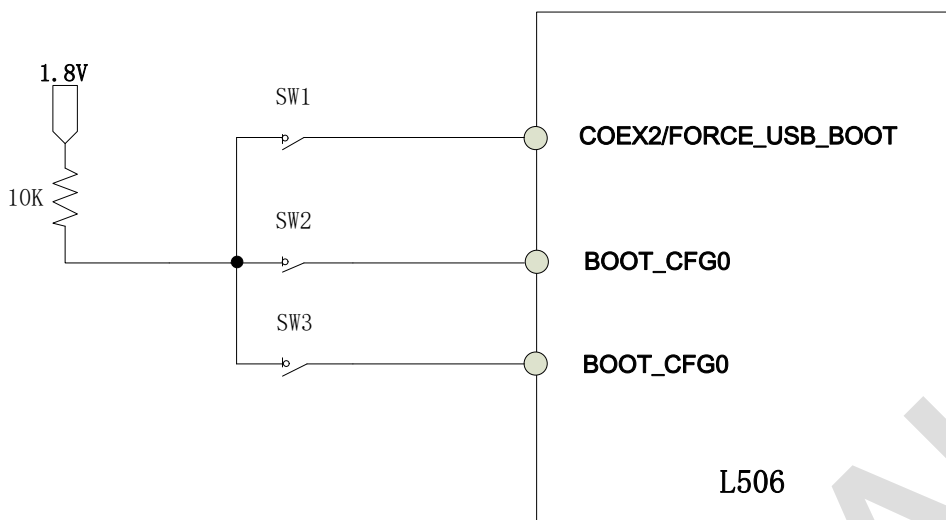

Figure 3-25 boot configuration and force USB download recommended circuit

### 3.14 WIFI interface (WIFI edition)

#### 3.14.1 WIFI interface definition

L506 WIFI edition definition as below

Table 3-24 WIFI interface definition

PIN	Net name	Description	Region
33	SDC1_DATA0	SDIO	CPU
29	SDC1_DATA1		
27	SDC1_DATA2		
31	SDC1_DATA3		
32	SDC1_CMD		
36	SDC1_CLK		
30	WLAN_EN	WIFI module enable control	CPU
83	COEX1	COEX_UART_TX, LTE and WIFI coexistence synchronization	CPU
84	COEX2	COEX_UART_RX, LTE and WIFI coexistence synchronization	CPU
35	WLAN_32K_SLEEP_CLK	WLAN Clock	PMIC
15	VDD_1.8V	PMIC ( VREG_L11_IP8 ) LDO 1.8V output, power supply to WLAN	PMIC

		SDIO 1.8V	
34	VREG_L2_1V8	PMIC LDO 1.8V output power supply to WLAN VDDIO_XTAL	PMIC

### 3.14.2 WIFI interface application

L506 default support QCA9377, application diagram is as follows:

- This reference based on QCA9377 do external WLAN.
- Because of WLAN chip on electric timing and power supply capacity, L506 pin 34, pin 15 both are 1.8 V LDO output, but they cannot mix use.
- Figure 3-27(a) TPS22921YFPR and ISL91127 WLAN3.3 V power solutions, customers can also choose other DCDC power supply, ensure WLAN3.3 V power supply capacity is greater than 600 mA
- Figure 3-?(b) is the MOBILETEK WIFI module WM1601 application, detail please refer 《L506 reference design》 .

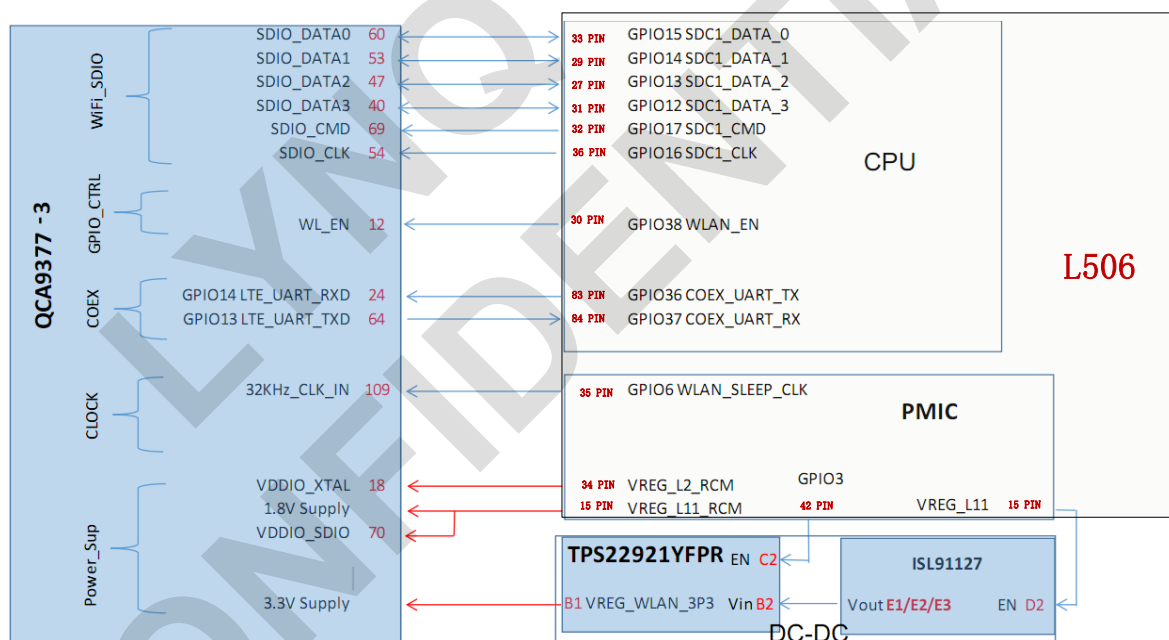

Figure 3-26WIFI interface application circuit (Base on QCA9377)

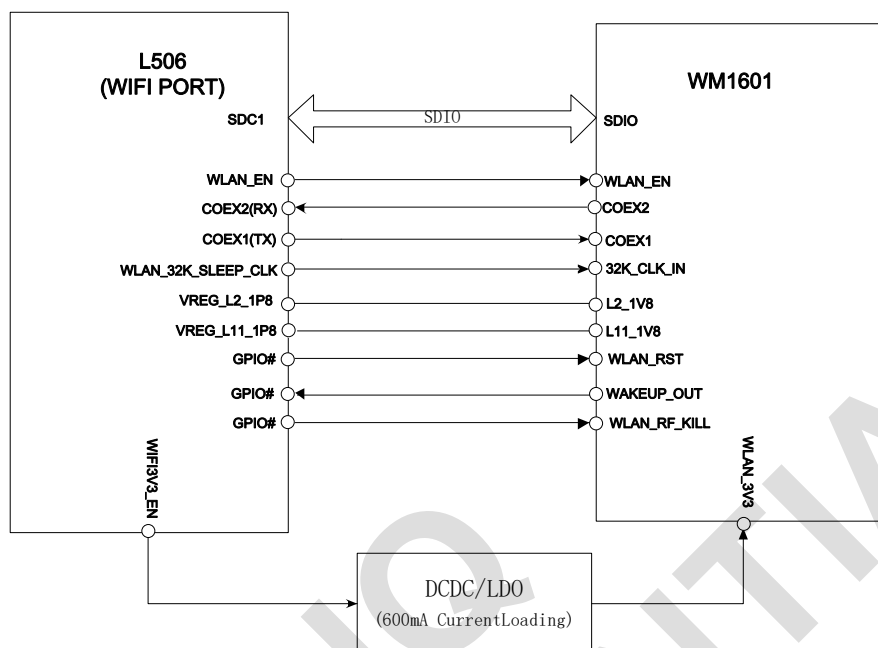

Figure 3-27 WIFI interface application circuit (MOBILTEK WM1601)

## 3.15 Analog and Digital conversion (ADC) interface

L506 integrated two analog-to-digital conversion interface, specific parameters are as follows:

Table 3-25 ADC1, ADC2 characters

characters	Min.	Typ.	Max.	Unit
ADCresolution	--	15	--	Bits
Transfer time	--	442	--	ms
Input voltage range	0.3	--	VBAT	V
Input resistance	1	--	--	MΩ

**Note:** 1. use "AT + CADC" and "AT + CADC2" can read ADC1 and ADC2 voltage on the pin.  
 More information please refer to the document [1].

2. The need for special software version to support access to the ADC.

## 3.16 I2C interface

### 3.16.1 I2C pin definition

I2C is used to communicate with peripheral equipment and can be operated as either a transmitter or receiver, depending on the device function. Both SDA and SCL are bidirectional lines connected with

I2C interface. Its operation voltage is 1.8V. High speed mode transmission rate can reach 400 KBPS, Because L506 have internal pulled up to the I2C interface, so in your design needn't pull up. Figure 3-15 is the reference design:

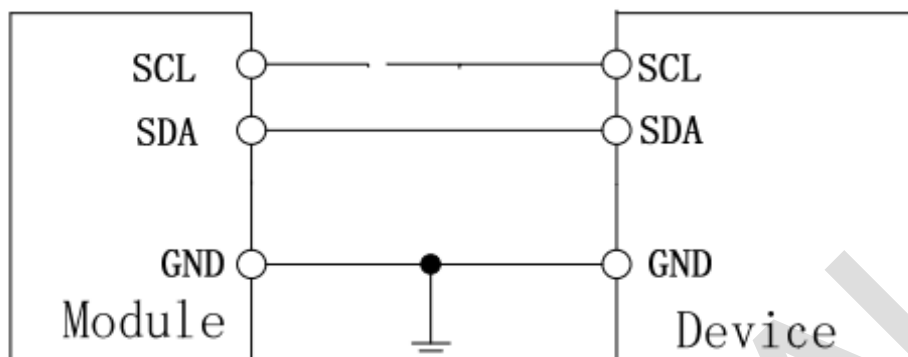

Figure 3-28 I2C reference design

Note: 1. L506 I2C only support host mode.

2. Only special software version support inquire the I2C.

## 3.17 Antenna interface

### 3.17.1 RF signal PCB layout guide

L506 provides RF antenna interface. Customer's antenna should be located in the host board and connected to module's antenna pad through micro-strip line or other types of RF trace and the trace impedance must be controlled in 50Ω. we recommends that the total insertion loss between the antenna pad and antenna should meet the following requirements:

- GSM900/GSM850<0.5dB
- DCS1800/PCS1900 <0.9dB
- WCDMA 2100/1900<0.9dB
- WCDMA 900/850<0.5 dB
- TDSCDMA 900/850<0.5dB
- CDMA BC0<0.5dB
- LTE (F<1GHz) <0.5dB
- LTE (1GHz<F<2GHz) <0.9dB
- LTE (2GHz<F) <1.2dB

To facilitate the antenna tuning and certification test, a RF connector and an antenna matching circuit should be added. The following figure is the recommended circuit.

The antenna feed point is defined as shown in below table:

Table 3-26 antenna pin definition

Pin No.	Signal	I/O Typ.	Description
82	MAIN_ANT	AI/AO	Module main antenna
59	AUX_ANT	AI	LTE diversity antenna feed point
79	GNSS_ANT	AI	GNSS antenna feeder connector

### 3.17.2 applications

For convenience of antenna tuning and certification test, should increase RF connectors and the antenna matching circuit, below is a recommended circuit:

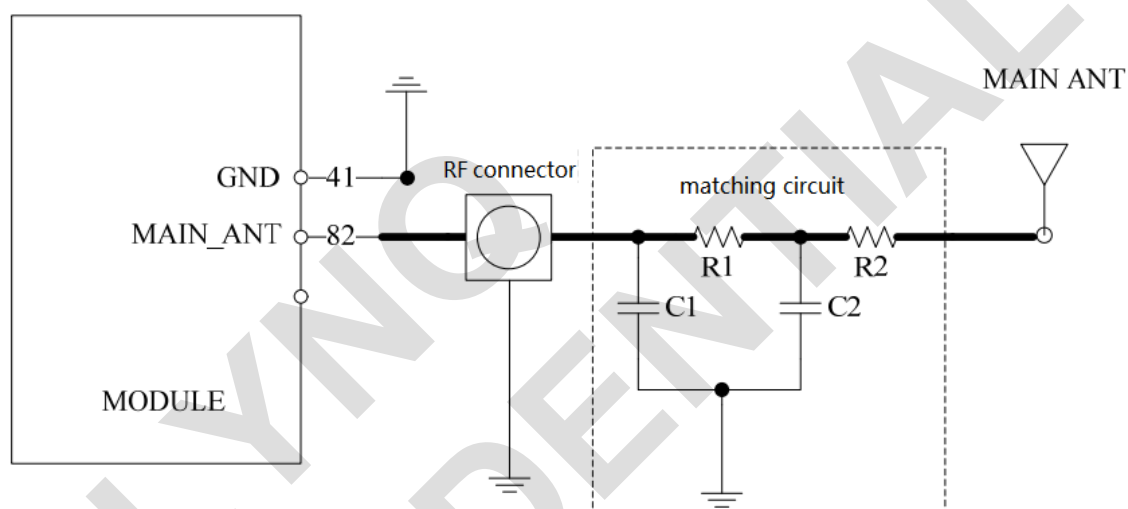

**Figure 3-29**Main antenna matching circuit diagram (MAIN\_ANT)

In this figure, the components R1, C1, C2 and R2 is used for antenna matching, the value of components can only be got after the antenna tuning, usually, they are provided by antenna vendor. By default, the R1, R2 are 0 Ohm resistors, and the C1, C2 are reserved for tuning.

The RF test connector in the figure is used for the conducted RF performance test, and should be placed as close as to the module's antenna pin. The traces impedance between components must be controlled in 50ohm.

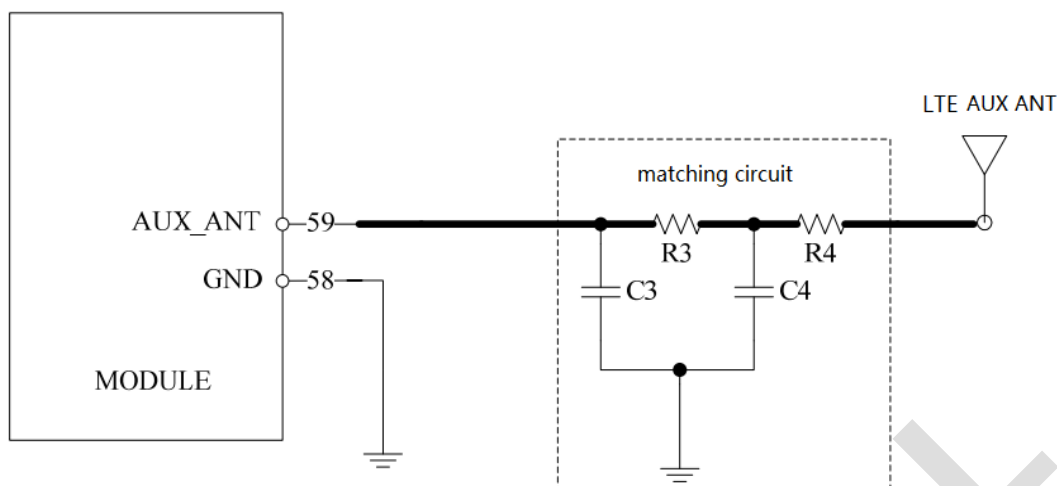

**Figure 3-30** LTE Diversity antenna matching circuit diagram (AUX\_ANT)

Note: LTE diversity antenna recommend leaving. Because there are many high frequencies of TDD LTE design, such as band38 band40 and Band41. Due to the high insertion loss RF line, if there is no diversity antenna, receiving sensitivity of the spectrum in the certification will be a risk.

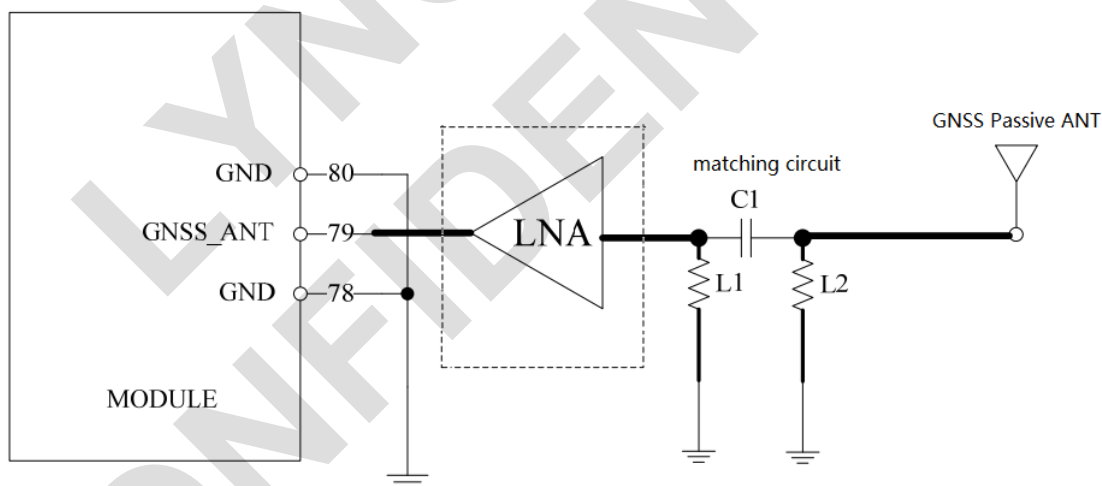

**Figure 3-32**GNSS passive antenna matching circuit diagram (GNSS\_ANT)

In above figures, the components C1 and L1, L2 are used for antenna matching, the values of the components can only be obtained after the antenna tuning usually, and they are provided by antenna vendor. GNSS can be used by NMEA port. User can select NMEA as output through UART or USB. NMEA sentences are automatic and no command is provided. NMEA sentences include GSV, GGA, RMC, GSA, and VTG. Before using GNSS, user should configure L506 in proper operating mode by AT command.

Please refer to related document for details. L506 can also get position location information through AT directly.

In the diagram above, component C1, L1 and L2 for antenna match, the element's value depends on the antenna after debugging. In figure 3-18, C2 for dc isolation. In the active antenna circuit, the user must use an external "/>

figure 3-19, the user can increase a external LNA gain to get better.

L506 merges GNSS (GPS/GLONASS) satellite and network information to provide a high-availability solution that offers industry-leading accuracy and performance. This solution performs well, even in very challenging environmental conditions where conventional GNSS receivers fail, and provides a platform to enable wireless operators to address both location-based services and emergency mandates.

- Tracking sensitivity:-159 dBm (GPS) -158 dBm (GLONASS)
- AcquisitionSensitivity: -148dBm
- Cold-start sensitivity:-142 dBm
- CN:C/N0 = S - (-170)                      S= Input Signal Intensity
- Accuracy (Open Sky): 2.5m (CEP50)
- TTFF (Open Sky:) Hot start <1s Cold start 35s
- Receiver Type:16-channel, C/A Code
- GPS L1 Frequency:1575.42±1.023MHz
- GLONASS: 1597.5~1605.8 MHz
- BEIDOU:                                      1559.05~1563.14 MHz
- Update rate Default:1 Hz
- GNSS data format:NMEA-0183
- GNSS Current consumption (WCDMA/GSM Sleep mode): 100mA (Total supply current)

#### Antenna Layout guideline

In layout design, antenna RF transmission line must ensure the characteristic impedance = 50 ohm. The characteristic impedance depend on substrate board, line width and the distance from the ground plane. As shown in figure 3-20 is the layout of antenna feed point of reference for clearance area.

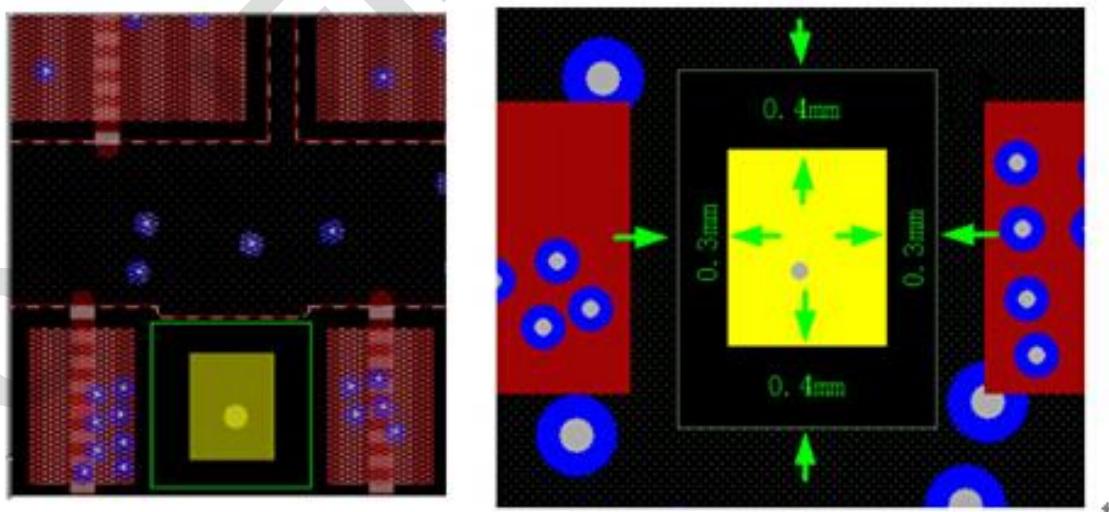

Figure 3-33 antenna feed point



## 4 Product characteristics

### 4.1 Absolute parameters

The following table shows the state of the absolute maximum work in abnormal situation. Exceed the limit value will likely result in permanent damage to the module.

Table 4-1 L506 absolute parameters

Parameter	Min.	Max.	Unit
VBAT absolute voltage parameter	-0.5	6.0	V
USB_VBUS absolute voltage parameter	-0.5	5.25	V
I/O absolute voltage parameter: PWRKEY, RESET, SPI, GPIO, I2C, PCM, UART, SD1_DET, USIM_DET	-0.3	2.1	V
I/O absolute voltage parameter: SD and USIM	-0.3	3.05	V

### 4.2 Operation condition

#### 4.2.1 Operation voltage

This product is a DC input voltage range of 3.4 V to 4.2 V, the typical value of 3.8 V, as shown in below table.

Table 4-2 Input DC voltage

Parameter	Min.	Typ.	Max.	Unit
VBAT Voltage	3.4	3.8	4.2	V
USB_VBUS Voltage	2.0	5.0	5.25	V

About L506 dc electric property, please refer to part 3.3 digital I/O characteristics.

#### 4.2.2 Work mode

Table 4-3 work mode

Mode	Description
Normal operation mode	(GSM/WCDMA /TD-SCDMA/EVDO/LTE)
	Sleep
	In this case, the current consumption of module will be reduced to the minimal level.
	In sleep mode, the module can still receive paging message and SMS.

(GSM/WCDMA /TD-SCDMA/EVDO/LTE) Idle	Software is active. Module is registered to the GSM/WCDMA/TD-SCDMA/EVDO/LTE network, and the module is ready to communicate.
(GSM/WCDMA /TD-SCDMA/EVDO) taking	Connection between two subscribers is in progress. In this case, the power consumption depends on network settings such as DTX off/on, FR/EFR/HR, hopping sequences, antenna.
(GPRS/EDGE/WCDMA/TD-SCDMA/EVDO/LTE) Standby	Module is ready for GPRS/EDGE/WCDMA/TD-SCDMA/EVDO/LTE data transfer, but no data is currently sent or received. In this case, power consumption depends on network settings and EDGE/HSPA+ /LTE configuration.
(GPRS/EDGE/WCDMA/TD-SCDMA/EVDO/LTE) Data transfer	There is GPRS/EDGE/WCDMA/TD-SCDMA/EVDO/LTE data transfer in progress. In this case, power consumption is related to network settings (e.g. power control level); uplink/downlink data rates and GPRS configuration (e.g. used multi-slot settings).
Minimum mode	AT command "AT+CFUN" can be used to set the module to a minimum functionality mode without removing the power supply. In this mode, the RF part of the module will not work or the USIM card will not be accessible, or both RF part and USIM card will be closed, and the serial port is still accessible. The power consumption in this mode is lower than normal mode.
Flight mode	Use the "AT + CFUN = 7" command or lower FLIGHTMODE pins, the module can be configured to flight mode under without removing the power supply condition. In this case, the RF part does not work, but still can use the serial port and USB, the power consumption is lower than normal working mode.
Power off	Through the "AT + CPOF" command or lower PWRKEY pin can power off L506. At this mode, the module of internal power supply will be closed, and the system is stop running also. The UART and USB are unavailable.
Sleep mode	In sleep mode, the module power consumption to a minimum, but the module is still able to receive paging information and SMS.

### 4.2.3 current consumption

The power consumption in suspended mode and without USB connection is listed in the table below.

Table 4-4 working current consumption (VBAT=3.8V)

<b>GNSS (Without USB)</b>	
(AT+CFUN=0)	@ -140dBm, Positioning, Typical: 72mA
<b>Power off</b>	
Power off current	20uA
<b>GSM Sleep/Idle</b>	
GSM/GPRS supply current (GNSS off, without USB)	Sleep mode @ BS_PA_MFRMS=2 Typical: 3mA Idle mode @ BS_PA_MFRMS=2 Typical: 20mA
<b>UMTS sleep/idle</b>	
WCDMA current (GNSS off, without USB)	Sleep mode @DRX=9 typical: 3.6mA Idle mode @DRX=9 typical: 19mA
TD-SCDMA current (GNSS off, without USB)	Sleep mode typical: 4mA Idle mode typical: 20mA
EVDO current (GNSS off, without USB)	Sleep mode typical: 3.8mA Idle mode typical: 20mA
<b>LTE Sleep/Idle</b>	
LTE supply current (GNSS off, without USB)	Sleep mode typical: 3.8mA Idle mode typical: TBD
<b>GSM Talking</b>	
GSM 900	@Power level #5 typical: 254mA
DCS1800	@Power level #0 typical: 182mA
<b>UMTS Talking</b>	
WCDMA B1	@power 24dBm typical: 565mA
WCDMA B2	@power 24dBm typical: 560mA
WCDMA B5	@power 24dBm typical: 535mA
WCDMA B8	@power 24dBm typical: 536mA
TD-SCDMA 1900	@power 24dBm typical: 150mA
TD-SCDMA 2000	@power 24dBm typical: 143mA
CDMA BCO	@power 24dBm typical: TBD
<b>GPRS Data transmission</b>	
GSM 900 ( 1RX, 4 TX)	@power level #5 typical: 460mA
DCS1800 ( 1RX, 4 TX)	@power level #0 typical: 425mA

GSM 900 ( 3RX, 2TX)	@power level #5 typical: 360mA
DCS1800 ( 3RX, 2TX)	@power level #0 typical: 267mA
<b>EDGE Data transmission</b>	
GSM 900 ( 1RX, 4 TX)	@power level #8 typical: 210mA
DCS1800 ( 1RX, 4 TX)	@power level #2 typical: 171mA
GSM 900 ( 3RX, 2TX)	@power level #8 typical: 317mA
DCS1800 ( 3RX, 2TX)	@power level #2 typical: 244mA
<b>HSDPA Data transmission</b>	
WCDMA B1	@power 24dBm typical: 565mA
WCDMA B2	@power 24dBm typical: 560mA
WCDMA B5	@power 24dBm typical: 535mA
WCDMA B8	@power 24dBm typical: 536mA
<b>TD-SCDMA Data transmission</b>	
TDSCDMA 1900	@power 24dBm typical: 141mA
TDSCDMA 2000	@power 24dBm typical: 149mA
<b>EVDO Data transmission</b>	
BC0	@power 24dBm typical: 500mA
<b>LTE Data transmission</b>	
LTE-FDD B1	@5Mbps typical: 716mA @10Mbps typical: 722mA @20Mbps typical: 750mA
LTE-FDD B2	@5Mbps typical: 626mA @10Mbps typical: 637mA @20Mbps typical: 661mA
LTE-FDD B3	@5Mbps typical: 656mA @10Mbps typical: 687mA @20Mbps typical: 721mA
LTE-FDD B4	@5Mbps typical: 656mA @10Mbps typical: 687mA @20Mbps typical: 721mA
LTE-FDD B5	@5Mbps typical: 556mA @10Mbps typical: 587mA

LTE-FDD B7	@5Mbps typical: 733mA @10Mbps typical: 766mA @20Mbps typical: 831mA
LTE-FDD B8	5Mbps typical: 591mA @10Mbps typical: 597mA
LTE-FDD B12	@5Mbps typical: 555mA @10Mbps typical: 584mA
LTE-FDD B13	@5Mbps typical: 546mA @10Mbps typical: 567mA
LTE-FDD B17	@5Mbps typical: 546mA @10Mbps typical: 567mA
LTE-FDD B20	typical: 600mA
LTE-TDD B38	@5Mbps typical: 420mA @10Mbps typical: 430mA @15Mbps typical: 450mA
LTE-TDD B39	@5Mbps typical: 365mA @10Mbps typical: 370mA @15Mbps typical: 392mA
LTE-TDD B40	@5Mbps typical: 401mA @10Mbps typical: 416mA @15Mbps typical: 445mA
LTE-TDD B41	@5Mbps typical: 417mA @10Mbps typical: 428mA @15Mbps typical: 448mA

### 4.3 Working and storage temperature

The operating temperature and storage temperature of L506 is listed in the following table.

Table 4-5 Operating temperature

Parameter	Min.	Typ.	Max.	Unit
Normal operation temperature	-30	25	80	°C
Extended operation temperature*	-40	25	85	°C
Storage temperature	-45	25	90	°C

**\*Note: Module is able to make and receive voice calls, data calls, SMS and make GPRS/WCDMA/HSPA+/LTE traffic in -40°C ~ +85°C. Temperatures outside of the range -30°C ~ +80°C might slightly deviate from ETSI specifications.**

## 4.4 ESD performance

L506 is electrostatic sensitive device, therefore, the user in the production, assembly and operation of the module must pay attention to the electrostatic protection. L506 ESD performance parameters in the following table:

Table 4-6 ESD performance parameters (temperature 25 °C, humidity: 45%)

Net	contact	air
VBAT GND	±5KV	±10KV
Antenna port	±4KV	±8KV
UART	±2KV	±4KV
USB	±3KV	±6KV
Other PADS	±2KV	±4KV

## 5 Design guideline

This chapter provides a general design of the products instruction, the user can refer to design guidance for design, make products to achieve better performance.

### 5.1 General design rules and requirements

Users in the design of this product is peripheral circuit, the first to ensure the external power supply circuit can provide enough power supply capacity, And the requirements for high speed signal lines USB control 90 ohm + / - 10% difference impedance. For general signal interface, require the user to us in strict accordance with the requirements of design, in line with the interface signal level matching, in case the level of damage to the module. This product its own radio frequency index is good, customers need to design in accordance with the requirements the mainboard side antenna circuit and corresponding impedance control, otherwise it will affect the whole RF index.

### 5.2 Reference circuit

Request system board VPH\_PWR side power supply ability of power supply to achieve more than 2 A, meet the demand of modules, peak current, and the system side the power of the average current will reach more than 0.9 A. System board side power supply cord shall ensure enough line width, and wants to form a good return with the ground plane, moreover should increase in the power supply circuit design the method of micro level energy storage capacitor, guarantee the instantaneous power supply capacity, and the power supply ripple control within the 100 mv, the specific function of each functional module can be found in the corresponding description, overall reference circuit design please refer 《L506 reference design》 .

### 5.3 RF part design guideline

#### 5.3.1 Early antenna design considerations

- Pre-project evaluation

The selection of the antenna position must first ensure that the antenna and the base station are kept in the horizontal direction, this produces the highest efficiency; Secondly, try to avoid placing the switch in the power supply or data line, chip and other devices or chips that produce electromagnetic interference. At the same time, the position of the hand can be avoided, so as to prevent the human

body to produce attenuation; But also to reduce the radiation and the structure of the realization of the need to take into account. So, At the beginning of the design need to structure, ID, circuit, antenna engineers together to evaluate the layout.

- **Antenna matching circuit**

If the module's radio frequency port and the antenna interface need to be transferred, the main board circuit design, The design of microstrip line or strip line between the module RF test base and the antenna interface between the microstrip line or the strip line by characteristic impedance 50 ohm, at the same time, reserved double L type matching circuit; If the antenna's RF connector can be directly stuck in the module's RF test base, can save the module of the RF port and the antenna interface between the transfer.

## 5.4 EMC and ESD design advice

Users should take full account of the EMC problem caused by signal integrity and power integrity in the design of the whole machine, In the module of the peripheral circuit layout, for power and signal lines, etc., to maintain the spacing of 2 times line width. Can effectively reduce the coupling between the signal, so that the signal has a clean, the return path. When the peripheral power supply circuit is designed, the decoupling capacitor should be placed close to the module power supply pin, High frequency high speed circuit and sensitive circuit should be far from the edge of PCB, and the layout of the layout as far as possible to reduce the interference between each other, and the sensitive signal is protected. The circuit or device that may interfere with the operation of the system board is designed.

This product is embedded in the system board side, design, need to pay attention to the ESD protection, the key input and output signal interface, such as (U) SIM card interface need to be placed close to the protection of ESD devices. In addition to the motherboard side, the user is required to design the structure and PCB layout, ensure that the metal shield is fully grounded, and set up an unobstructed discharge passage for the electrostatic discharge.

## 5.5 PCB Recommended land pattern

We recommend that users in the design of main board PCB DEF, In the middle of the 12 geothermal solder design according to size in below figure. Recommended at 87 of peripheral signal pads to the module with a length of 1.0 mm. Recommended PCB pads as shown in below.



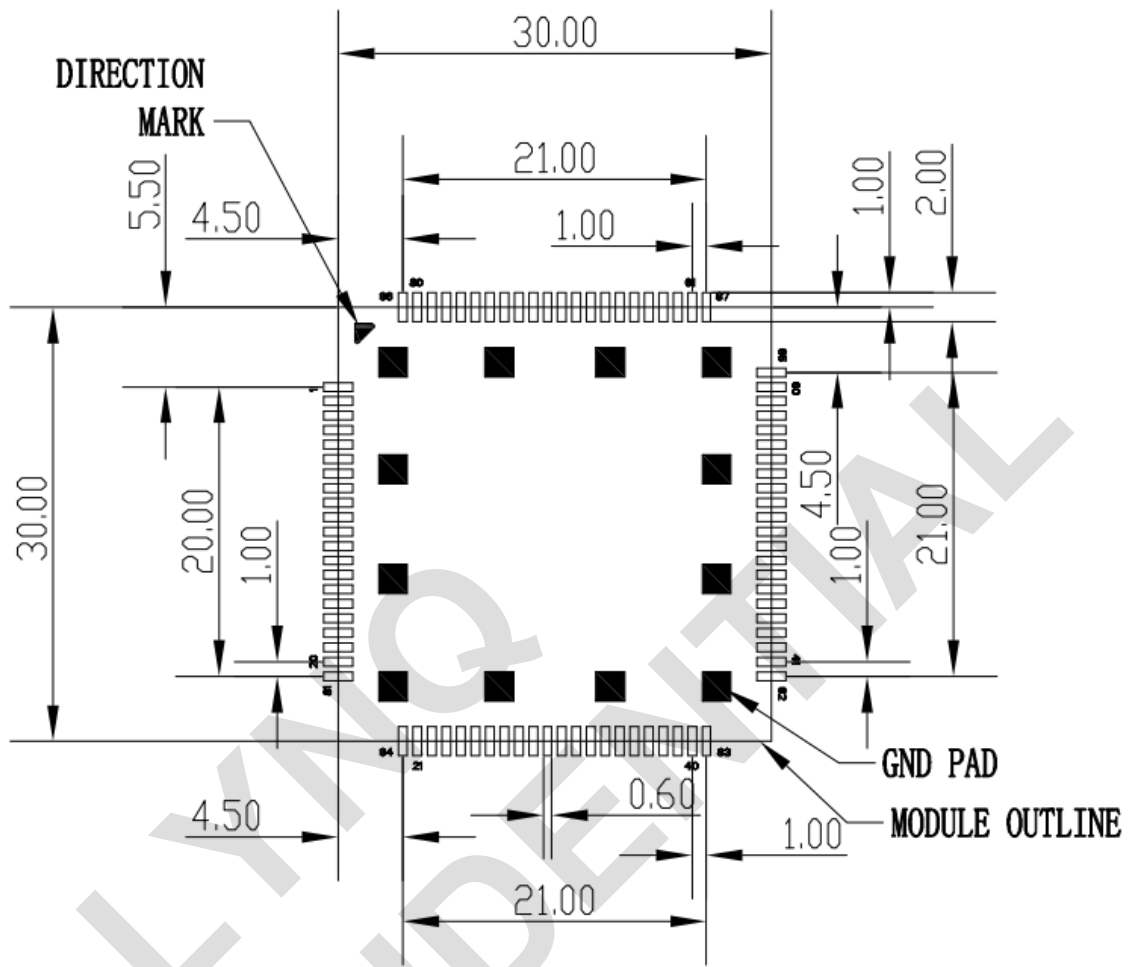

Figure 5-1 RECOMMENDED LAND PATTERN (Unit: mm) (detail A)

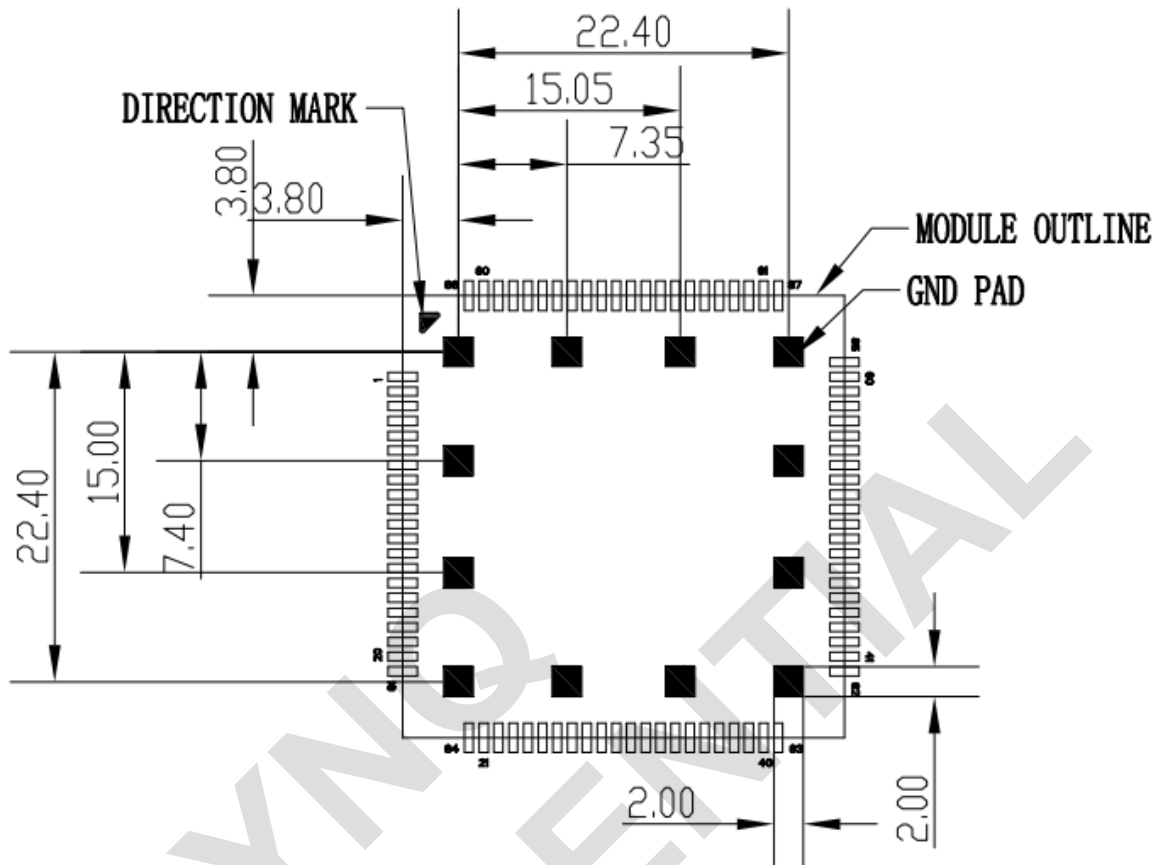

Figure 5-2 RECOMMENDED LAND PATTERN (Unit: mm) (detail B)

## 5.6 Products recommended upgrade

L506 default through the USB firmware updates, so products to facilitate the software update, when the design proposal to set aside the USB test points or interface to facilitate subsequent product of the firmware upgrade.

## 6 Manufacturers

### 6.1 Steel mesh design

- At the bottom of the module pad thermal, can be reduced by way of steel mesh openings, reduce the risk of short circuit between the thermal and the module of the module Pin, have certain effect;
- Module pad thermal welded steel mesh openings are recommended for reference. Figure 6-1 and Figure 6-2 is recommended for steel mesh and size.

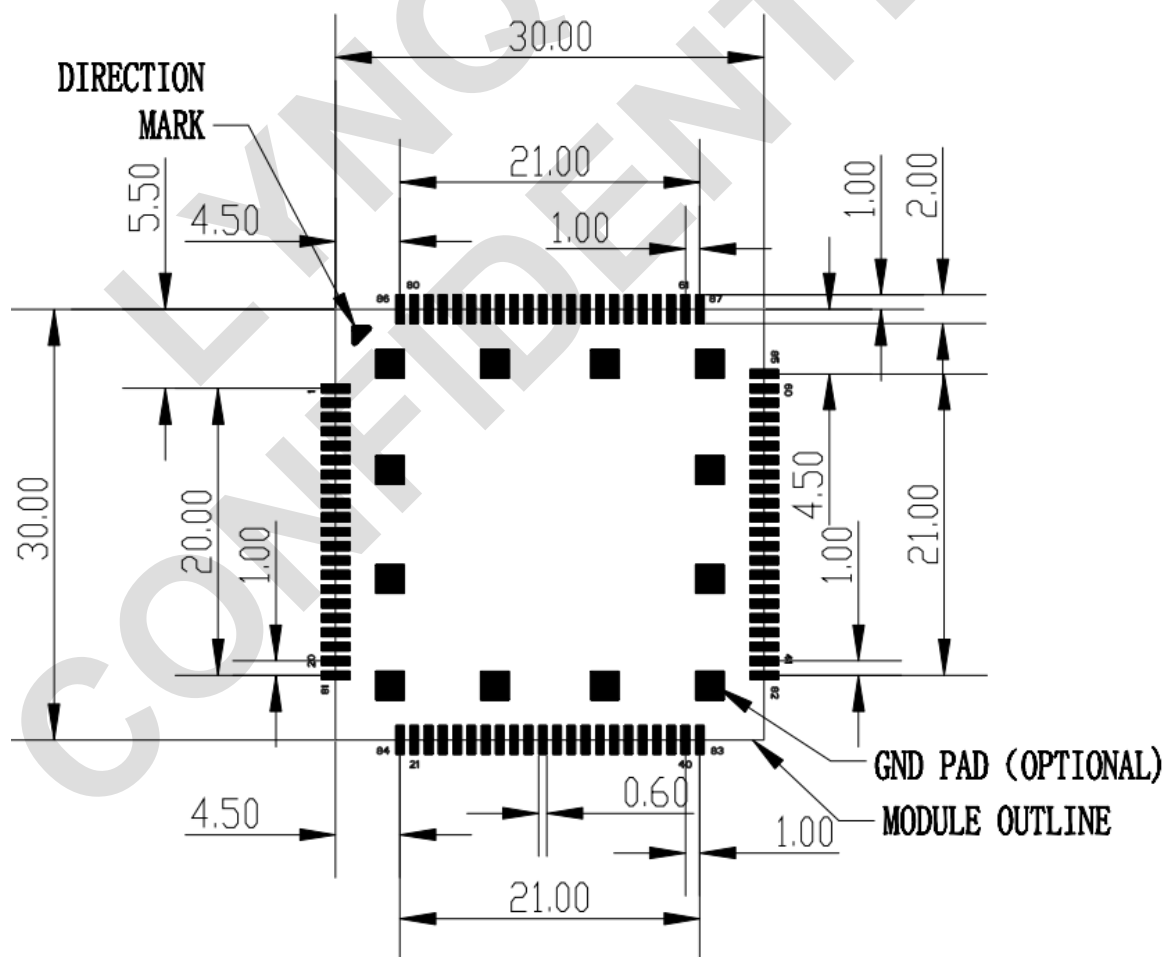

Figure 6-11 Steel mesh (unit mm)(detail A)

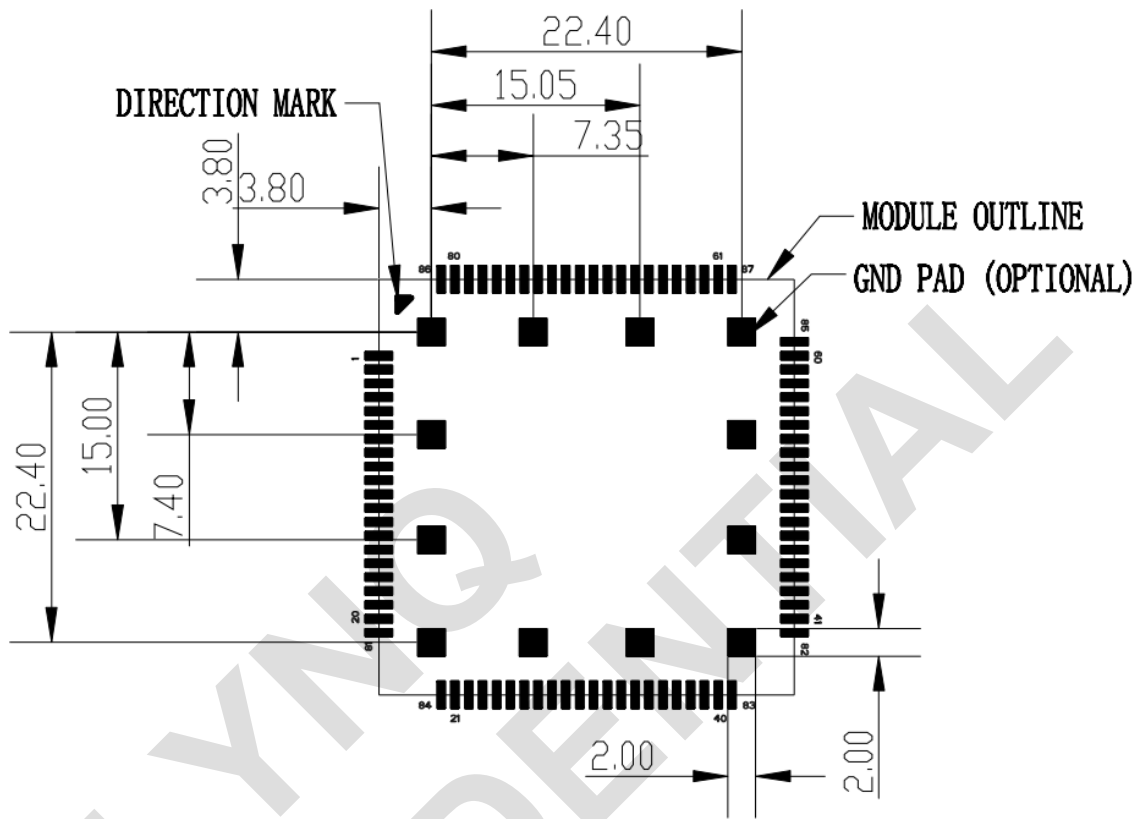

Figure 6-2 Steel mesh (unit mm) (detail B)

**Note:** The direction mark point only for identify the pin 1 position, should not embody in the steel mesh file.

## 6.2 Temperature curve

In order to ensure soldering quality, special attention should be paid to the control of temperature curve pipes. The soldering profile shown below is only a general recommendation and should be adjusted according to the specific application and manufacturing.

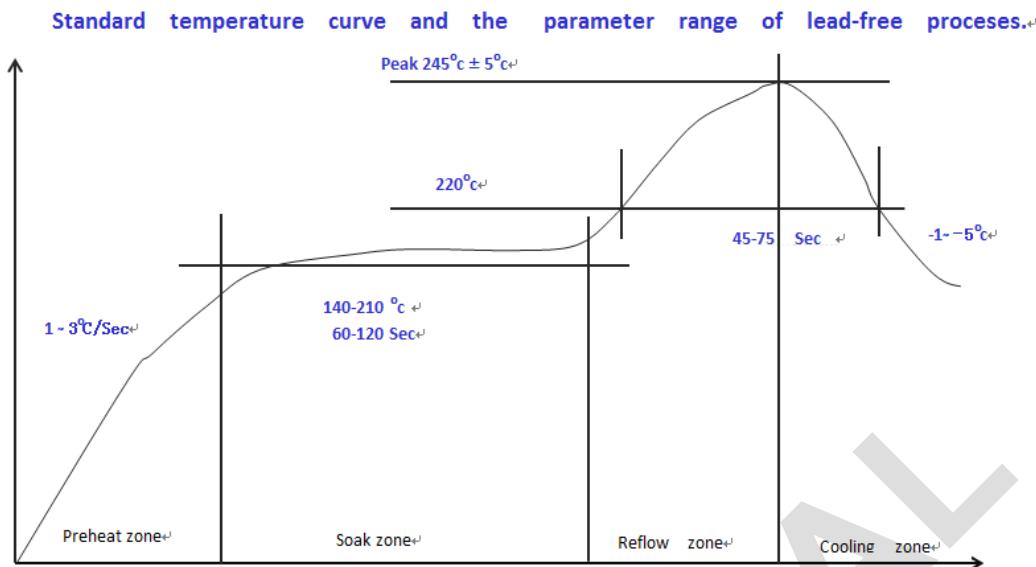

Figure 6-3 The reference temperature curve

### 6.3 The Moisture Sensitivity Level (MSL)

L506 module complies with the humidity level 3. At a temperature of <30 degrees and relative humidity of <60% of the environmental conditions, dry pack to perform J-STD-020C specification according to IPC / JEDEC standard. At a temperature of <40 degrees and a relative humidity of <90% of the environmental conditions, in the case of unopened shelf life of at least six months. After unpacking, Table 6-2 shows the module shelf life at different times corresponding to the level of humidity.

Table6-2: Moisture sensitivity level and floor life

The Moisture Sensitivity Level (MSL)	Floor Life(out of bag) at factory ambient $\cong +30 / 60\%RH$
1	Unlimited at $\cong +30 / 85\%$
2	1 Year
2a	4 weeks
3	168 hours
4	72 hours
5	48 hours
5a	24 hours
6	Mandatory bake before use. After bake, it must be reflowed within the time limit specified on the label.

After unpacking, <30 degrees in temperature and relative humidity <60% environmental conditions, 168 hours in the SMT patch. If not meet the above conditions need to be baked.

**NOTES:** For product handling, storage, processing, IPC / JEDEC J-STD-020C must be followed

## 6.4 Baking Requirements

Due to the humidity sensitive characteristics of the L506 module, the L506 is a vacuum packaging, which can be stored for 6 months without damage to the package, and the ambient temperature is less than 40 C and the relative humidity is less than 90%. To meet one of the following conditions, the process of reflow soldering should be performed before the full bake (if trays are used, please note whether the tray is heat-resistant.), or the module may cause permanent damage to the process.

- 1、 Vacuum packing damage or leakage
- 2、 The module is exposed in the air for 168 hours or more
- 3、 The module is exposed in air for 168 hours, not meet the temperature <30 degrees and relative humidity of the environment conditions <60%

Table6-3:Baking requirements

Baking temperature	Humidity	Baking time
120° C±5° C	<5%	4 Hours

**Note:** The original packaging of the module cannot bear the high temperature of baking. The packaging needs to be removed before baking, otherwise the packaging will be damaged.

# 7 Package Storage information

## 7.1 Package information

### 7.1.1 Tape and reel information

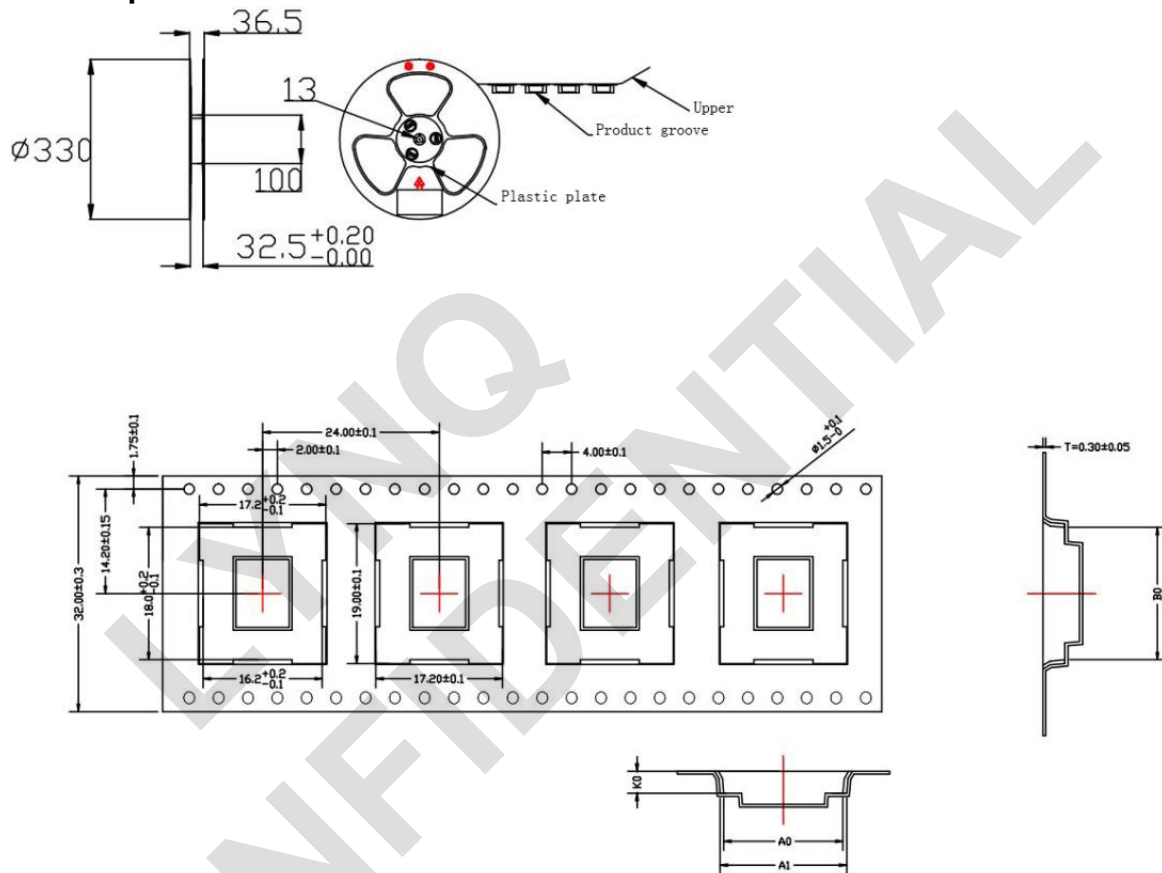

Figure 7-1 Tape and reel information

### 7.1.1 Package information

L506 packing diagram is as follows, every 4 volumes of material packed in a case between each volume of material has a bubble mat do isolation protection. Specific as shown in the figure below:

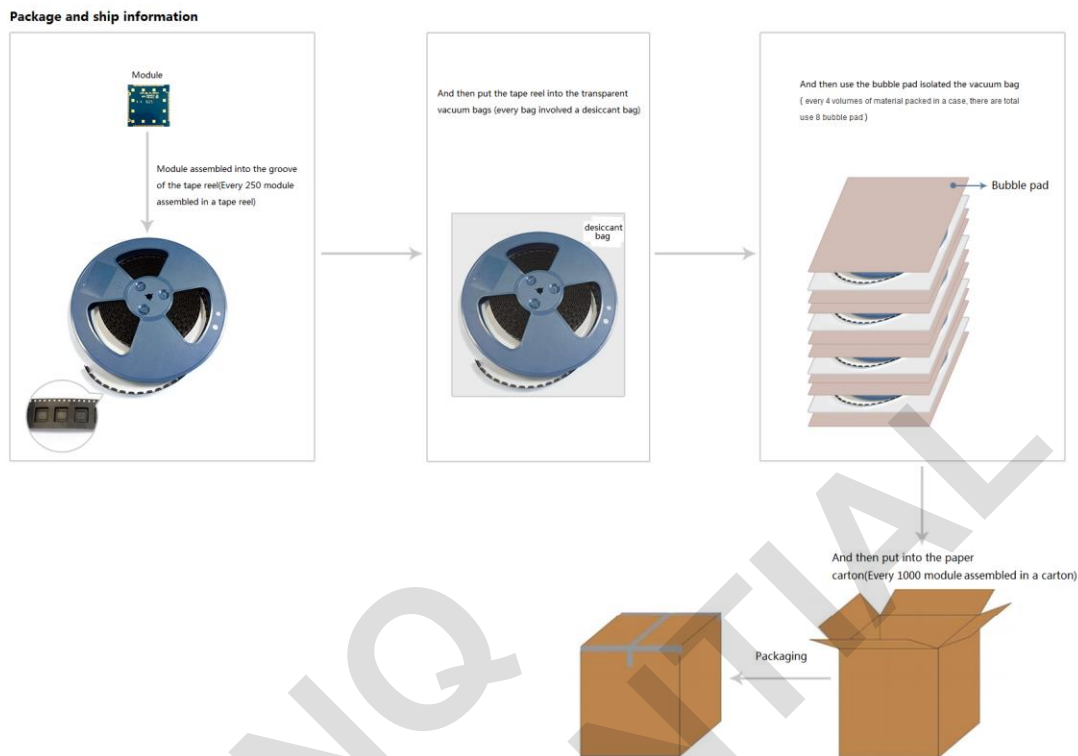

Figure 7-2 Package and ship information

## 7.2 Bagged storage conditions

L506 shipments in the form of vacuum sealing anti-static bag. Module of storage need to follow the following conditions: Environment below 40 Degrees Celsius temperature, air humidity is less than 90% of cases, the module can be in vacuum sealed bags for 12 months. Conditions set the storage environment Suggestions with reference to the following form.

Table 7-1 Storage conditions (less than 90% humidity of the air vacuum sealed packaging)

Parameter	Min.	Typ.	Max.	Unit
Storage temperature	-45	25	90	°C

When on the vacuum bags, if meet the following conditions, the module can be directly for reflow soldering (furnace temperature setting reference 6.2 furnace temperature curve) or other high temperature process:

- Module temperature below 30 degrees c, the air humidity is less than 60%, factory within 72 hours to complete the SMT.
- The humidity is less than 10%.

If the module is in the following conditions, to be baked before SMT:

- When the environment temperature is 23 degrees Celsius (allow upper and lower volatility of 5 degrees Celsius), humidity index greater than 10%.
- When open vacuum bags, module temperature below 30 degrees Celsius, air humidity is less than 60%, but the factory have not finished the SMT within 72 hours.
- When open the vacuum bags, module storage air humidity is more than 10%.



## 8 Safety Information

For the reasonable usage of the module, please comply with all these safety notices of this page. The product manufacturers should send followed safety information to user, operator or product's spec.



The devices using the module may disturb some electronic equipment. Put the module away from the phone, TV, radio and automation equipment to avoid the module and the equipment to interfere with each other.



Shut down the mobile device or change to flying mode before boarding. The Using of wireless appliances in an aircraft is forbidden to avoid the interference, or else cause to unsafe flying, even violate the law.



In hospital or health care center, switch off the mobile devices. RF interference may damage the medical devices, like hearing-aid, cochlear implant and heart pacemaker etc.



Mobile devices can't guarantee to connect in all conditions, like no fee or with an invalid SIM card. When you need emergent help, please remember using emergency calls and make sure your device power on in an area with well signal.



Put the module away from inflammable gases. Switch off the mobile device when close to gas station, oil depot, chemical plant etc.



The module is not water proof. Please don't use the module in the area with high humidity like bathroom, which will decelerate the physical performance, insulation resistance and mechanical strength.



Non-professionals can't teardown the module which will damage it. Refer to the specification or communicate the related staffs to repair and maintain it.



Please switch on the module before cleaning. The staffs should be equipped with anti-ESD clothing and gloves.

The users and product manufacturers should abide by the national law of wireless modules and devices. If not, Mobiletek will not respond the related damages.