

# CB12v100

## NON-SPILLABLE RECHARGEABLE SEALED LEAD ACID BATTERY

### ■ DIMENSION

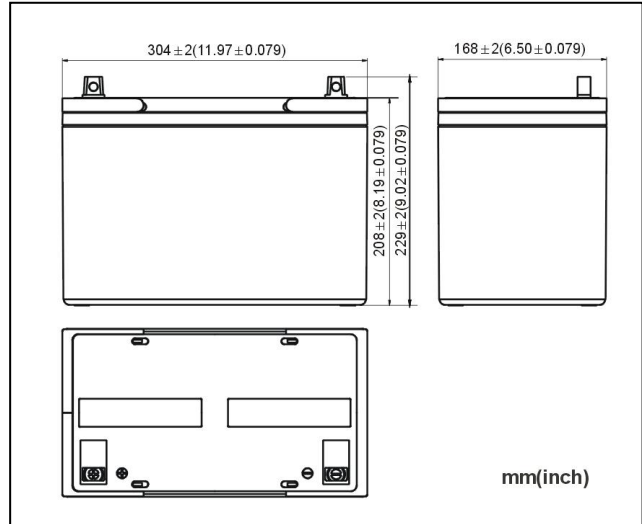

### ■ FEATURES

- Designed life for floating charge is 10 years (20°C);
- AGM valve regulated sealing technology;
- High strength ABS material for container & lid;
- Wide temperature scope of application (-15~45°C);
- Best temperature of application (20±5°C);
- No leaking, safe and reliable;
- Standing or lying down for using, convenient to transport and install;
- High sealed reaction efficiency, little loss of water, no need to add distilled water or electrolyte, simple to use and maintain;
- Low self-discharge rate.

### ■ TERMINAL

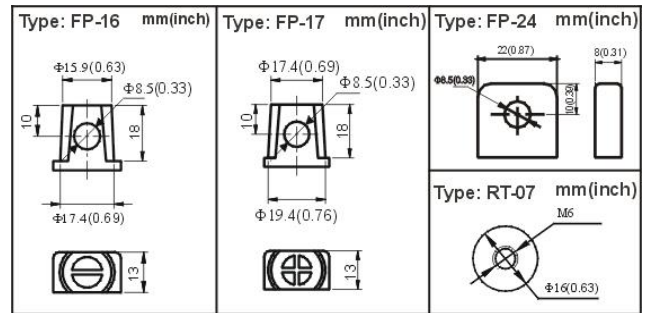

### ■ SPECIFICATIONS

Nominal Voltage	12V	Capacity	C <sub>10</sub>	100Ah (10.5V, at 25°C)
Nominal Capacity (C <sub>10</sub> )	100Ah (10.5V, at 25°C)		C <sub>5</sub>	72Ah (10.5V, at 25°C)
Dimension	Length 304mm		C <sub>3</sub>	67.5Ah (10.5V, at 25°C)
	Width 168mm		C <sub>1</sub>	49.5Ah (10.2V, at 25°C)
	Height 208mm	Internal Resistance		Approx. 6.5 mΩ (25°C)
	Total Height 229mm	Max Short-duration Discharge Current		1800A(25°C)
Weight	Approx. 30.17kg	Terminal	FP-16, FP-17/FP-24/RT-07	

# CB12v100

## NON-SPILLABLE RECHARGEABLE SEALED LEAD ACID BATTERY

### ■ CHARGE

Using Mode	Charging Voltage	Temperature Compensation	Max Charging Current
Standby Use	2.275±0.025V/cell (25°C)	-3.3mV/°C/cell	27A
Cyclic Use	2.45±0.05V/cell (25°C)	-5mV/°C/cell	

### ■ STORAGE

- Batteries should be stored in dry and clean warehouse which has good air exchange system. Batteries should avoid direct sunlight. Batteries should not be near to heat (such as radiator, the distance should more than 1m). Batteries should avoid any toxic gas and organic solvent.
- When the ambient temperature is less than 25°C, the longest storage life is 6 months. If ambient temperature is higher, the longest storage life varies as specified in below chart.

Storage Temperature (°C)	≤25	26~33	34~40
Storage Time (Month)	6	3	1

- Batteries should be recharged within the storage life or before using.

Charging methods: maximum charging current 27A, constant voltage 2.45±0.05V/cell (25°C);

Charging time: 15~20h; Temperature compensation coefficient: -5mV/°C/cell.

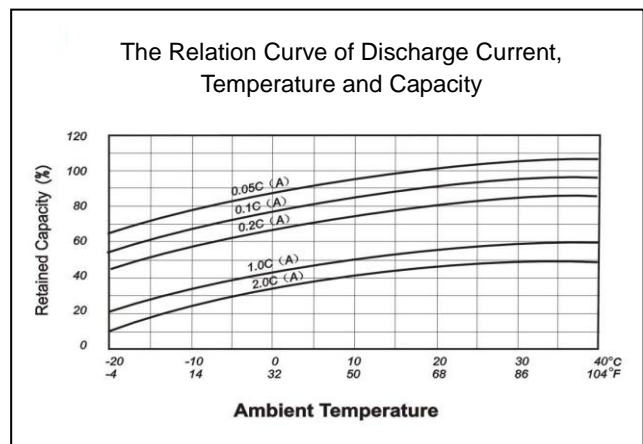
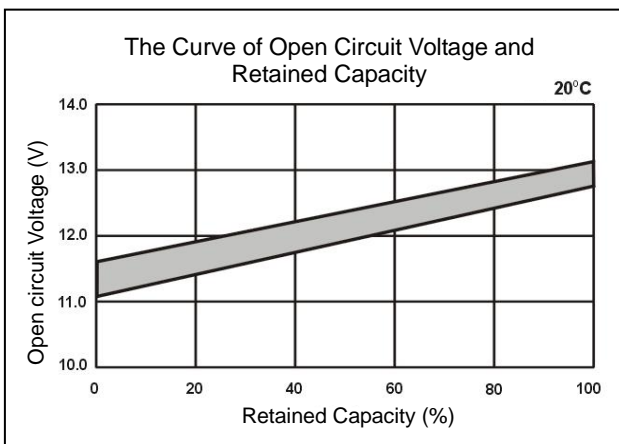
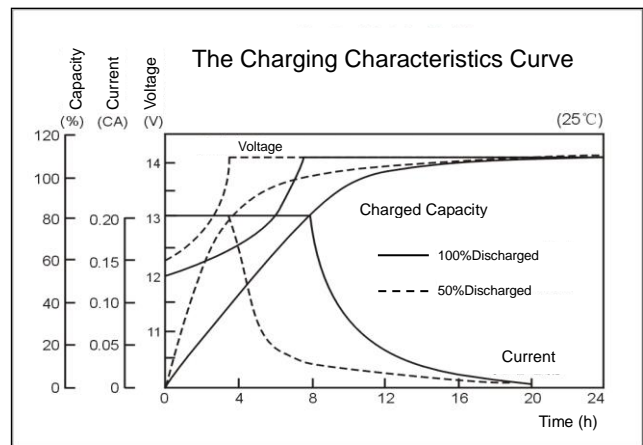
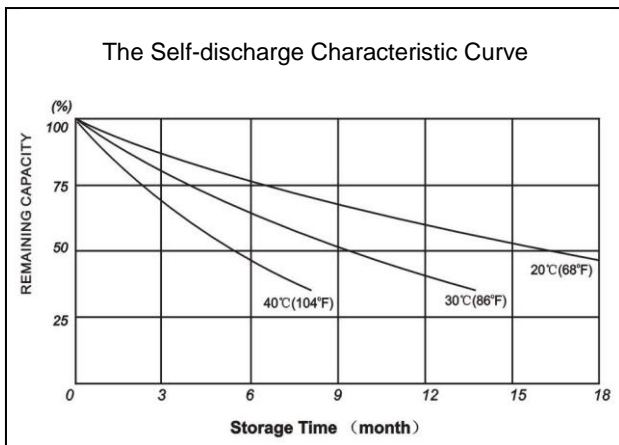

Issue: SC-CB12900-001-CGB-201407. For the improvement of products and technology, and the appearance of the specifications are subject to change without prior notice. The company has the right of final interpretation.