

SW15
width across
flats: 15

SW16
width across
flats: 16

assembly aid enclosed

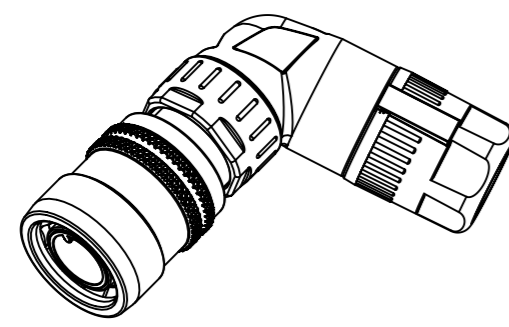
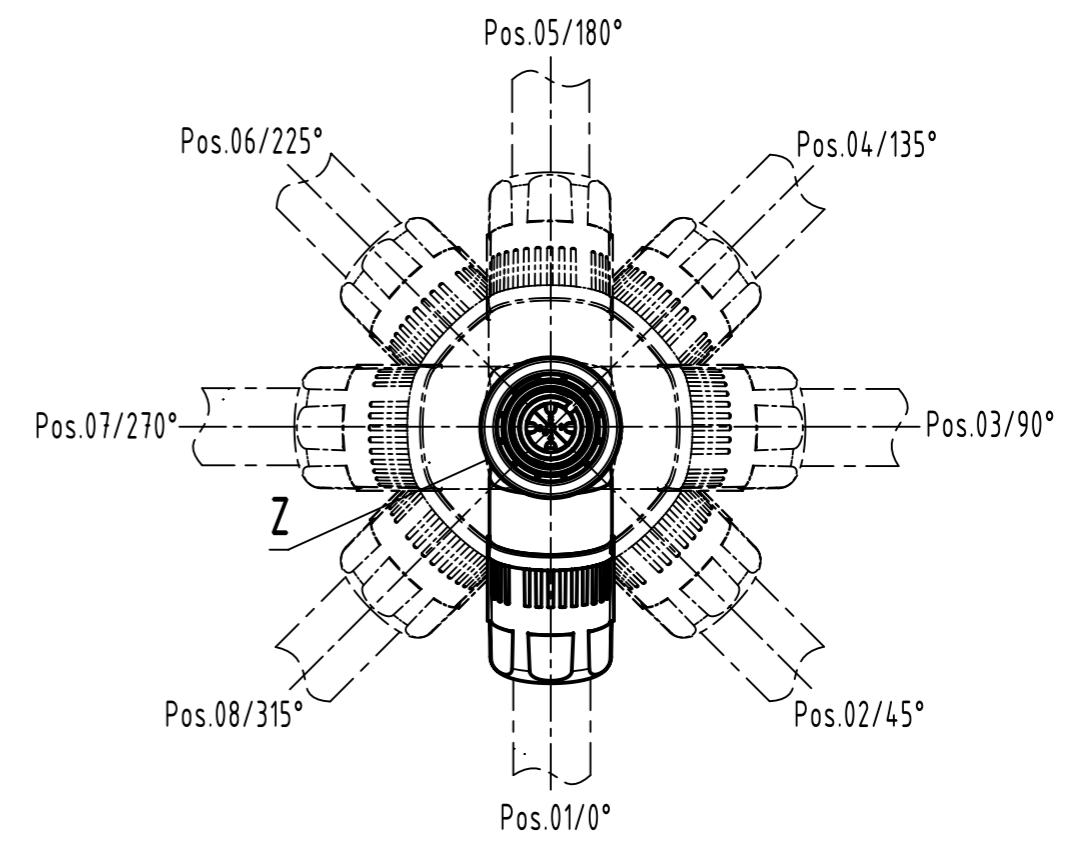
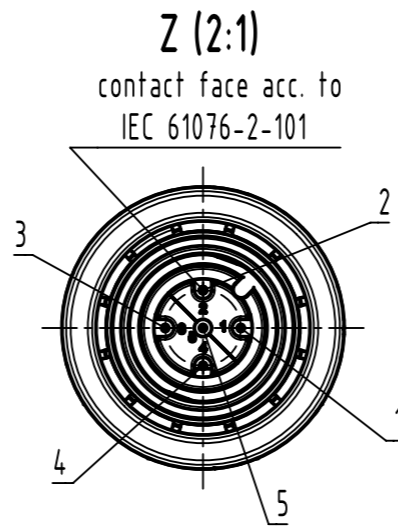

order contacts separately

cable Ø	wire gauge	contact part-no.
5,7-8,8mm	AWG 26-22	09 67 000 5576
	AWG 24-20	09 67 000 8576
	AWG 22-18	09 67 000 3576

	All rights reserved Department EL PD	All Dimensions in mm Original Size DIN A3	Scale 1:1	Free size tol.	Ref. Sub.
		Created by SERBANA	Inspected by FARCASIU	Standardisation ROEBEN	Date 2023-03-21
HARTING D-32339 Espelkamp		Title M12-PP-CC-CRIMP-5P-ACOD-M-ANG-SHLD			Doc-Key / ECM-Nr. 100682330/UGD/003/J 50000239888
		Type TB	Number 21038213530		Rev. J Page 1/1