

A
B
C
D

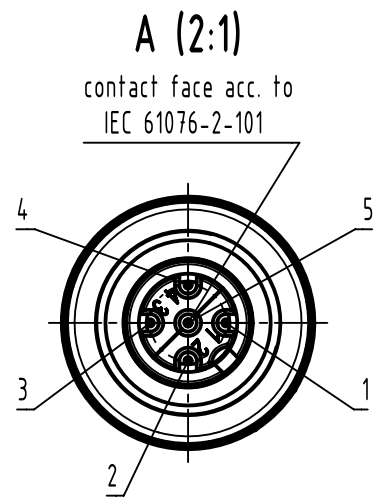

order contacts separately

Cable description	Cable diameter	Wire gauge	P/N contact	P/N Crimping insert	P/N Crimping Tool	P/N Mounting tool
BETATRANS GWK-ENX C-FLEX EN 50306-4 3P 300V 2x0,75mm ² Leoni: 314709	5,4mm	AWG 22-18	09 67 000 3476	09 99 000 0667	0999 000 0647	0999 000 0639
BETATRANS GWK C-FLEX R 600/1000V 2x0,75mm ² Leoni: 223386	5,3mm	AWG 22-18	09 67 000 3476	0999 000 0652	0999 000 0647	0999 000 0639

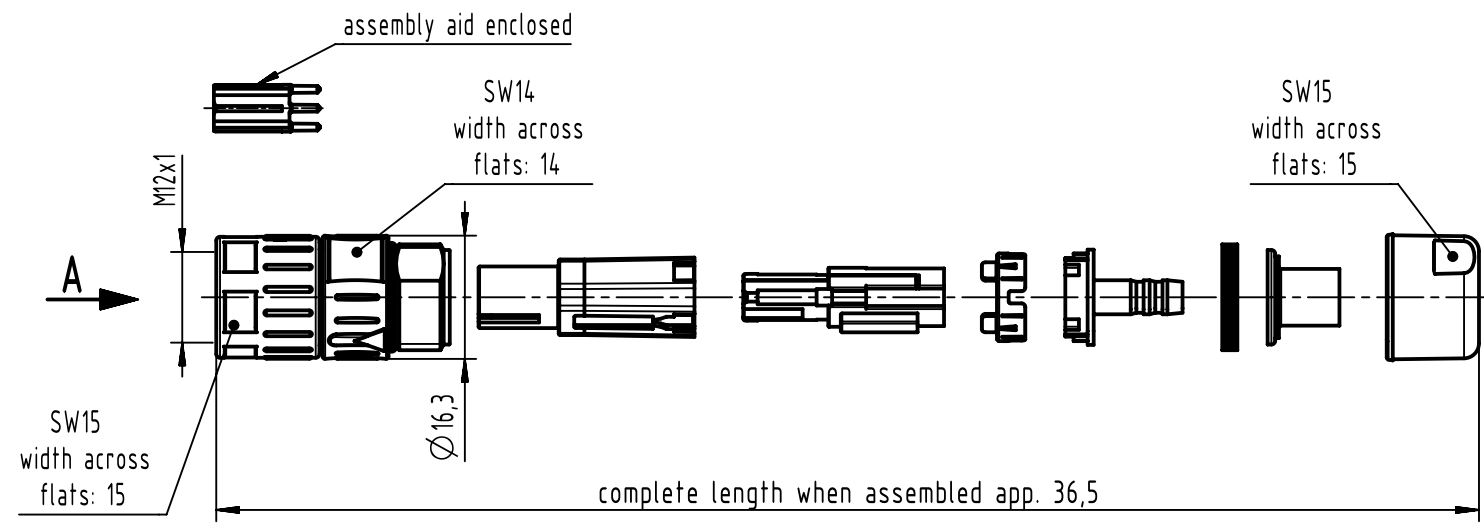
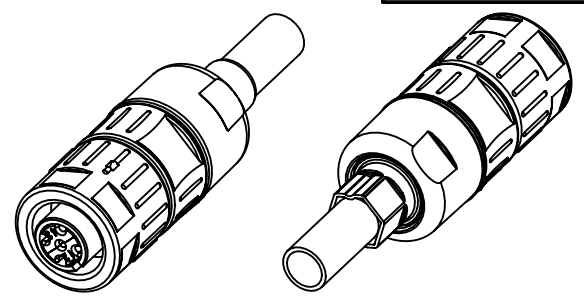

	All Dimensions in mm Original Size DIN A4	Scale 1:1	Free size tol.		Ref.
	All rights reserved Department EL PD	Created by 406403	Inspected by FARCASIU	Standardisation ROEBEN	Sub.
HARTING D-32339 Espelkamp	Title M12 SD A-cod 5-pol Crimp Flange female				Date 2022-11-25 State Final Release
	Type TB Number 21038212511				Doc-Key / ECM-Nr. 100699015/UGD/002/H 500000231088 Rev. H Page 1/1