

REVISION RECORD				
REV	ECN	DESCRIPTION	DRFT	DATE

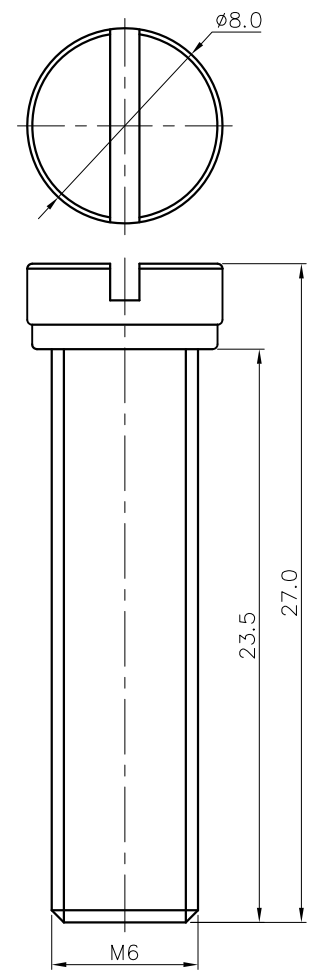
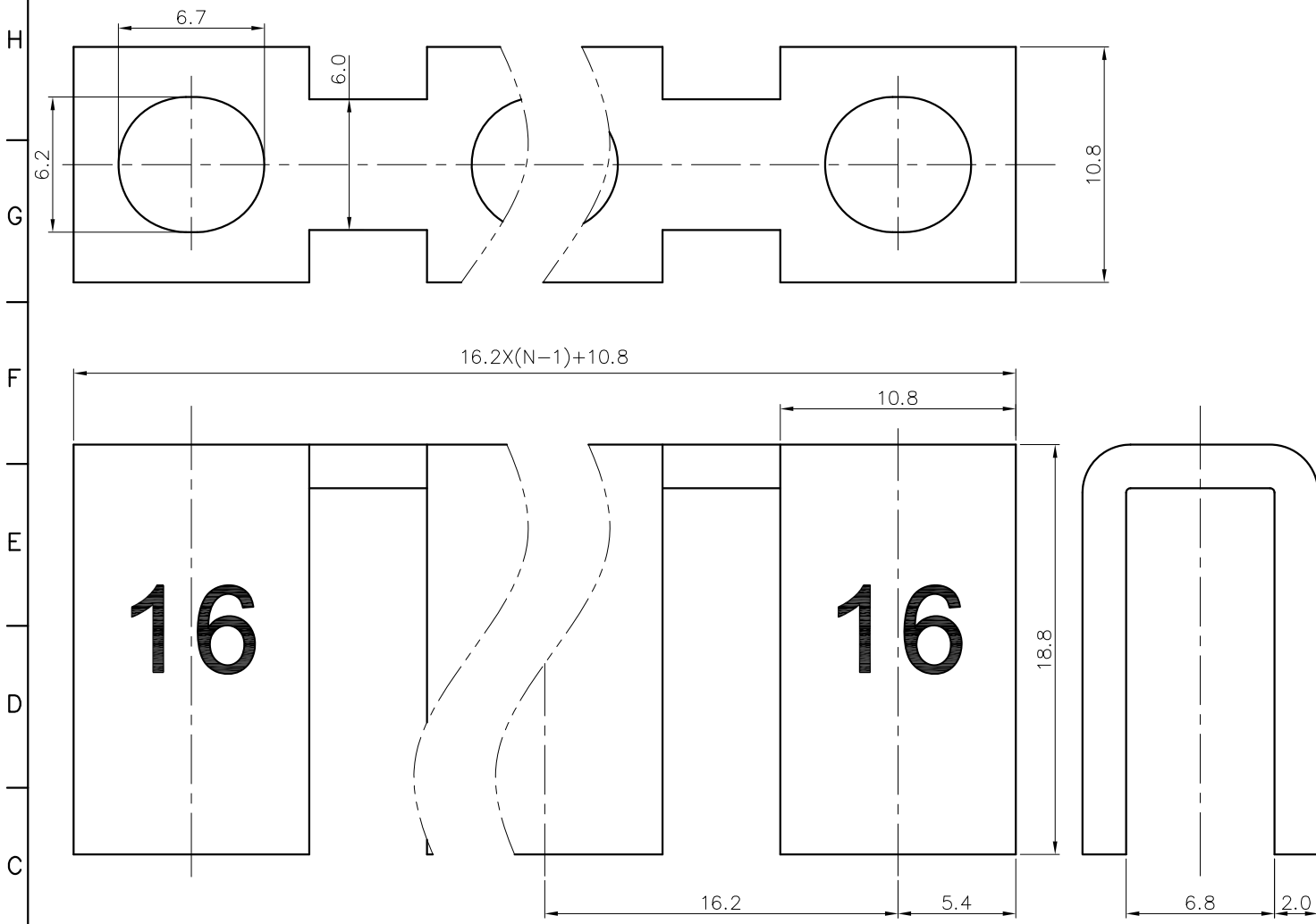

NOTES1:
 UL Standard
 1.Torque value : M6 , 22.2Lb.in
 IEC Standard
 1.Torque value : M6 , 2.5N·m

NOTES2:
 1.Dimension shall be interpreted per ASME Y14.5-2009
 2.Pitch : 16.2mm, Poles : 02P/03P
 3.Undimensioned tolerances:

Pitch Range In mm		Nominal Dimension Range In mm					0.1/10	0.1/10
TO	TO	TO	TO	TO	TO			
6	10	10	30	30	60	100	150	
±0.15	±0.20	±0.30	±0.30	±0.50	±0.70	±1.00	±1.30	
							±2'	

4.RoHS Compliance

DETACHED LISTS	PART NO.:	/			
	APPD:	/			
	CHKD:	/			
	DRFT:	/			
		宁波高松电子有限公司 NINGBO DEGSON ELECTRICAL CO., LTD			
		NAME: FBIXX-16			
		TITLE: CUSTOMER DRAWING	REV	D0	
		DRAWING NO.:	/		SHEET 1/1
		THIRD ANGLE PROJECTION	DO NOT SCALE DRAWING	SCALE	1:1