

D

C

B

A

4

4

3

3

2

2

1

1

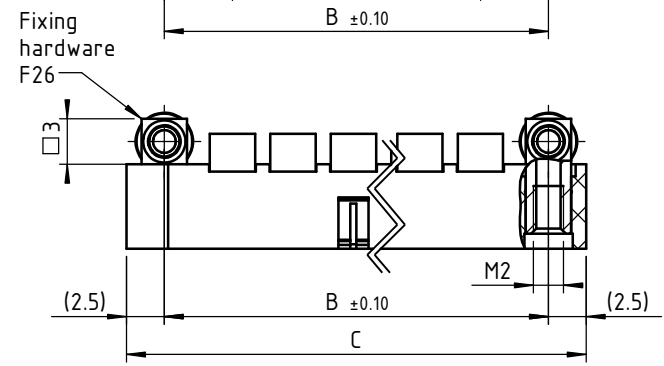
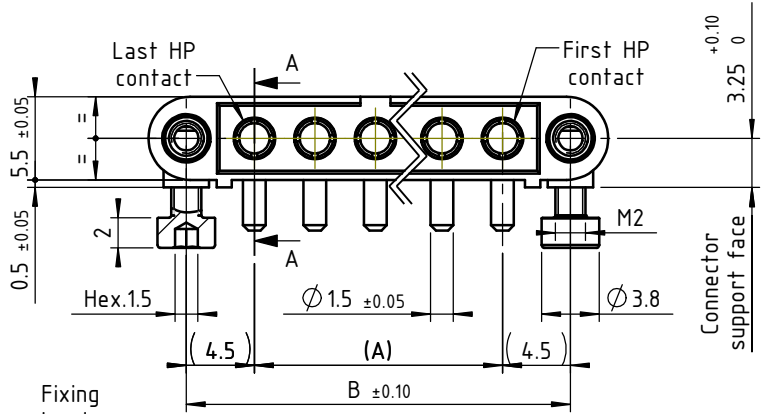
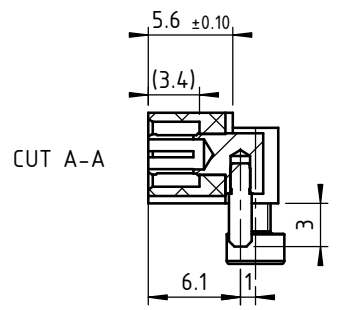

Recommended PCB layout:

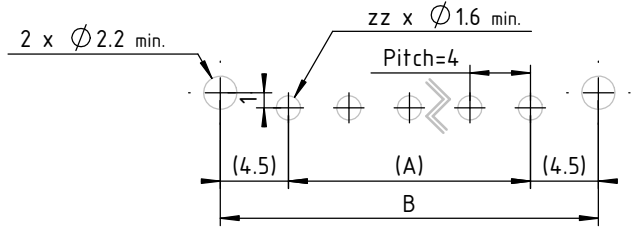

### TECHNICALS FEATURES

#### MATERIALS

INSULATOR : Special PPS (Polyphenylene sulphide fibreglass filled thermoplastic) UL 94-V0

- Radiation resistance
- No humidity absorption
- Oxygen free

Note : PPS characteristics are recognized for space applications

#### FIXING HARDWARE :

- Jackscrew : Stainless steel

### TECHNICAL FEATURES for 30 HP CONTACTS

#### MATERIAL

- Body and contact tail : Copper alloy / Ni + Au 0.5µ

#### MECHANICAL

- Endurance : 500 cycles min up to 2500.
- Insertion force : From 0.60 to 5N per contact
- Extraction force : From 0.50 to 2N per contact
- Secure overlapping : 1.30 mm

#### ELECTRICAL

- Intensity : 20 A
- Contact resistance : max. 6 mΩ
- Maximum voltage (sea level) : 1000V (RMS)
- Operating voltage (sea level) : 180 V AC/500 mA

#### ENVIRONMENTAL

- Temperature range : From -60°C to +260°C
- Vibration severity : 0.75mm, 10 g RMS 6 hours long random with superimposed sinusoid. No intermitencies measured when using an H.S.L.I. (High Speed Logic Interrupt) detector with a trip threshold of 2 ns. 100g for 6 ms
- Shock severity : HcFc 141 bMGX (ATOCHEM) solvent
- Solvent resistance : 96 hrs
- Salt spray test : 56 days @ 90% humidity
- Humidity test : 56 days @ 90% humidity



CMM Series 220 MALE			
HP contacts number zz	Distance between axes		Length in mm
	A	B	
02	4	13	18
03	8	17	22
04	12	21	26
05	16	25	30
06	20	29	34
07	24	33	38
08	28	37	42
09	32	41	46
10	36	45	50
11	40	49	54
12	44	53	58
13	48	57	62
14	52	61	66
15	56	65	70



3D view scale : 1.5:1

Marking as referenced in the CMM catalogue pages 12 & 13

 www.nicomatic.com Mail : nicomatic@nicomatic.fr Tel : +33 (0)4.50.36.13.85	3	25/07/16	C.Ga.		C.B.
	Iss	Date	Drawn	Checked	Approved
Item : Connector CMM220 male 90° on PCB, zz HP contacts 30-3400-CMM, F26					
Folder : X:\Méthodes\Plans clients\Plans clients 2D\10 - CMM220\Connecteurs mâles\221D\221D00F26-00zz-3400CMM_ct					

This document and drawings, sketches, and schematic drawings are the property of the NICOMATIC company, and no parts thereof may be reproduced and used without the written consent of the owner. Law dated 11.03.1902

Catalogue Reference : 221D00F26-00zz-3400CMM

General tolerance	±0.2	Scale	2:1	Page	1/1
-------------------	------	-------	-----	------	-----

D

A4