

REVISION RECORD				
REV	ECN	DESCRIPTION	DRFT	DATE

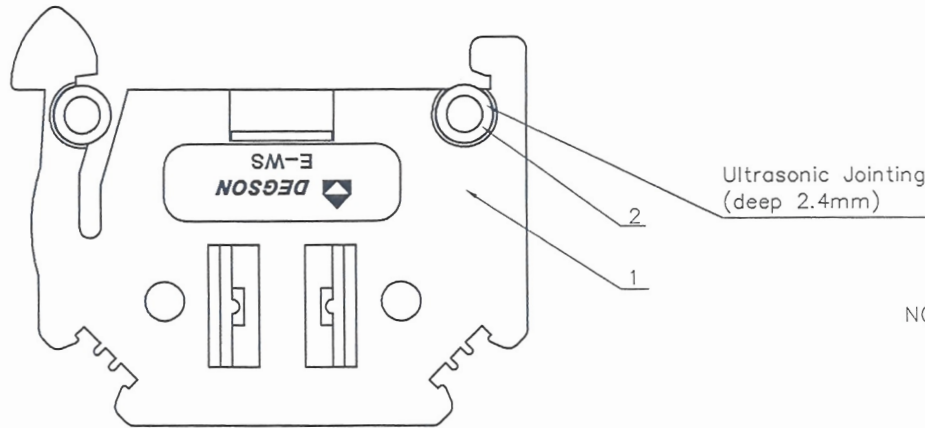

Ultrasonic Jointing
(deep 2.4mm)

NOTES:

- 1.Dimension shall be interpreted per ASME Y14.5-2009
- 2.Operating temperature: -40°C~+105°C
- 3.Used in Rail Din35
- 4.E-WS is the fixed part for the product of WS series
- 5.Undimensioned tolerances:

Pitch range in mm		Nominal dimension range in mm						0.1/10
TO	Over TO	Over TO	Over TO	Over TO	Over TO	Over TO		
6	10	24	30	60	100	150	<	
±0.15	±0.20	±0.30	±0.30	±0.50	±0.70	±1.00	±1.30	±2'

6.RoHS Compliance

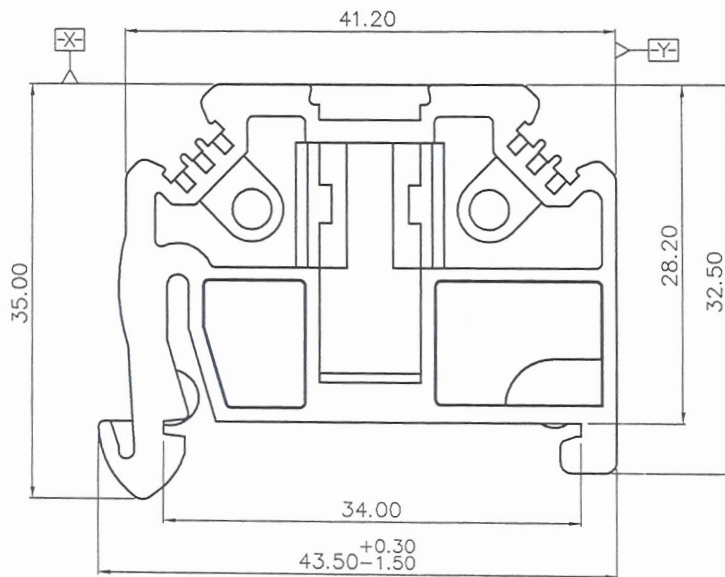
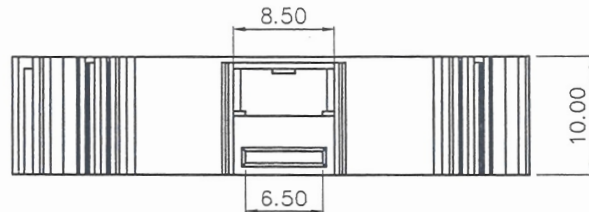

E-WS - 01P - 1Y - 00A (H)
 (Series No.) (Poles) (Single Pitch) (Color): 1.(Grey)
 2.(Blue)
 3.(Black)
 4.(Green)
 5.(Orange)
 6.(Red)
 7.(Transparent)
 8.(Yellow)
 9.(White)
 (RoHS)
 00A-(Standard)

奇复
06.7
(仅限内部使用, 对外无效)

ITEM	NAME OF PART	MATERIAL	NOTES
2	E-WS-Stator	Stainless steel	
1	E-WS-Housing	PA66	UL94V-0

DETACHED LISTS	PART NO.: /	宁波高松电子有限公司 NINGBO DEGSON ELECTRICAL CO., LTD		
	APPD: Aaron 2017.06.08	NAME: E-WS-01P-1Y-00A(H)		
	CHKD: Penny 2017.6.8	TITLE: CUSTOMER DRAWING		
	DRFT: YYC 2017.06.06	REV TO		
THIRD ANGLE PROJECTION		DRAWING NO.: E-WS-C01	SHEET 1/1	
		MM (INCH)	DO NOT SCALE DRAWING	SCALE 1:1