

# SPECIFICATION FOR APPROVAL

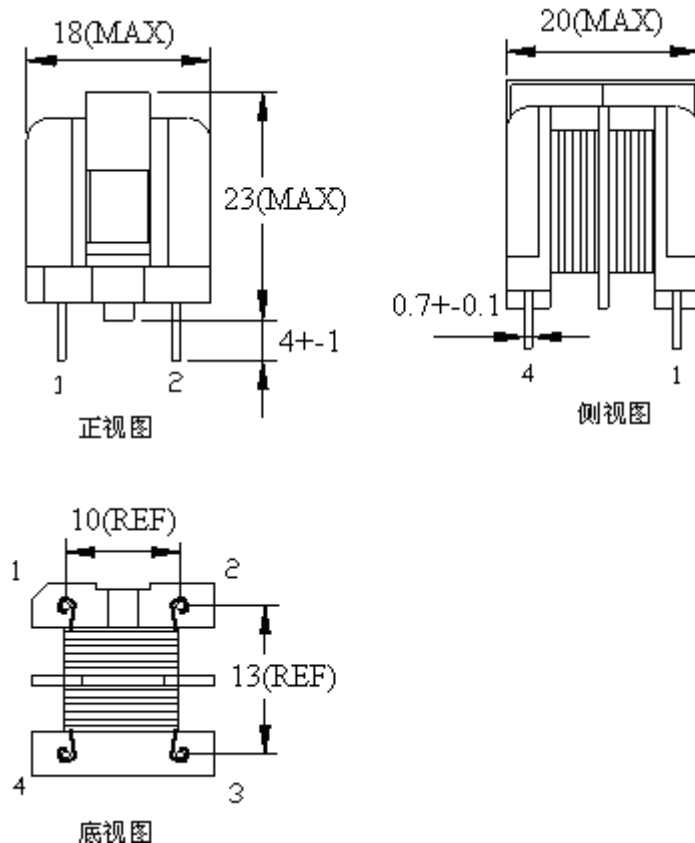

CUSTOMER :	DATE :
PART NO: LFU10V-183	DWG.NO: HX1210011
CUSTOMER PART NO :	CUST.DWG.NO :

(1) UNIT: mm

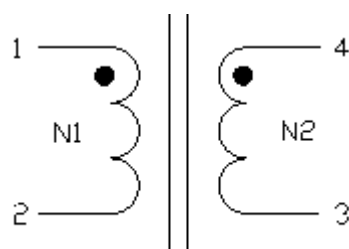

(2) SCHEMATIC:



DRAWN BY 	CHECKED BY 	APPROVED BY 
---	---	--

**CORE MASTER ENTERPRISE CO., LTD.**

TEL:886-2-8919-1288    FAX:886-2-8919-1298    WEB:www.coremaster.com.tw



# SPECIFICATION FOR APPROVAL

CUSTOMER :		DATE :	
PART NO: LFU10V-183		DWG.NO: HX1210011	
CUSTOMER PART NO :		CUST.DWG.NO :	
PARAMETER	TERMINAL	SPECIFICATION	TEST INSTRUMENTS
INDUCTANCE	L (1-2)=(4-3)	18mH (MIN)	1KHz/0.25V
RDC: (25°C)	RDC (1-2)=(4-3)	0.3Ω (MAX)	
IDC	IDC (1-2)=(4-3)	0.56A (MAX)	
HI-POT	PIN1-PIN4	AC 1500V/5mA/3SEC	
	PIN1,4-CORE	AC 500V/5mA/1SEC	
MATERIAL	SPEC	SUPPLIER	REMARK
CORE	UU10.5		
WIRE	2UEW φ 0.3mm		
WINDING	95TS(REF)		
BOBBIN	UU10.5+鐵夾		
DRAWN BY 		CHECKED BY 	APPROVED BY 

**CORE MASTER ENTERPRISE CO., LTD.**

TEL:886-2-8919-1288    FAX:886-2-8919-1298    WEB:www.coremaster.com.tw

# SPECIFICATION FOR APPROVAL

CUSTOMER :			DATE :		
PART NO: LFU10V-183			DWG.NO: HX1210011		
CUSTOMER PART NO :			CUST.DWG.NO :		
繞組	START	END	WIRE SIZE	TURNS(TS)	TAPE(TS)
N1	1	2	Φ0.3	95(REF)	2
N2	4	3	Φ0.3	95(REF)	2
DRAWN BY 			CHECKED BY 		APPROVED BY 

**CORE MASTER ENTERPRISE CO., LTD.**

TEL:886-2-8919-1288    FAX:886-2-8919-1298    WEB:www.coremaster.com.tw