

深圳市华普微电子有限公司
SHEN ZHEN HOPE MICROELECTRONICS CO.,LTD

Datasheet

Model NO.: HC-49S-27.13827-15-2020

Product code:40602700133

Quartz Crystal

Town,Nanshan District,Shenzhen,China

Tel: +86-755-82973805 ext:825

website: www.hoperf.com

email:hyhp@hoperf.com

1. ELECTRICAL PARAMETERS

No.	Characteristic	Limits	Remark
1.1	Nominal Frequency	27.13827MHz	
1.2	Mode of vibration	fund	
1.3	Load capacitance	15pF;	
1.4	Frequency Tolerance	±20ppm	Measure at 25°C±3°C
1.5	Equivalent Series Resistance	25Ω max	
1.6	Operating Temperature Range	-40°C~+85°C	
1.7	Frequency Stability	±20ppm	Over Operating Temperatuer Range
1.8	Storage Temperature Range	-55°C~+125°C	
1.9	Drive Level	100μW max	
1.10	Insulation Resistance	500MΩ	At 100V DC
1.11	Shunt Capacitance	7.0pF max	
1.12	Motional Capacitance		
1.13	Aging Per Year	±2ppm	First Yeat
1.14	Resistance Variation vs. Drive Level		
1.15	Frequency Variation vs. Drive Level		

2. RELIABILITY SPECIFICATIONS

No.	Test Item	Test Conditions	Reference
2.1	High Temperature Storage	Temperature: 125°C±10°C Time: 1000±24Hours	MIL-STD-883E
2.2	Temperature Cycle	Temperature 1: -55°C±10°C Temperature 2: 125°C±10°C Temperature change between T1 and T2 at soonest Run 10 cycles,maintain T1 and T2 30minutes each in one cycle	MIL-STD-883E
2.3	Solder Heat Resistance	Pre-heat: 125°C 60~120 Seconds Solder Temperature: 260°C±10°C Time: 5 Seconds	MIL-STD-202F
2.4	Drop Test	3 Times Free Fall from 75cm height table to 3cm thickness hard wood board	MIL-STD-202F
2.5	High Temperature High Humidity Storage	Temperature: 85°C Relative Humidity: 85% Time: 1000Hours	MIL-STD-883E
2.6	Steam Aging	Temperature: 97°C Time: 8Hours 230°C solder pot to check solderability	MIL-STD-883E
2.7	Solderability	Dip in flux 5~10 seconds Temperature: 280°C±10°C Time: 5 Seconds	MIL-STD-883E
2.8	Aging	Temperature: 85°C Time: 300Hours	MIL-STD-883E
2.9	Thermal Shock	Temperature1: -55°C±10°C Temperature2: 125°C±10°C Temperature change between T1 and T2: 5 seconds 10 cycles,maintain T1 and T2 for 30 minutes each in one cycle	MIL-STD-202F
2.10	Vibration	Frequency Range: 10HZ~1000HZ Amplitude: 1.5mm 40mins in each direction,total 120mins	MIL-STD-883E

3. OUTLINE DIMENSIONS (unit:mm)

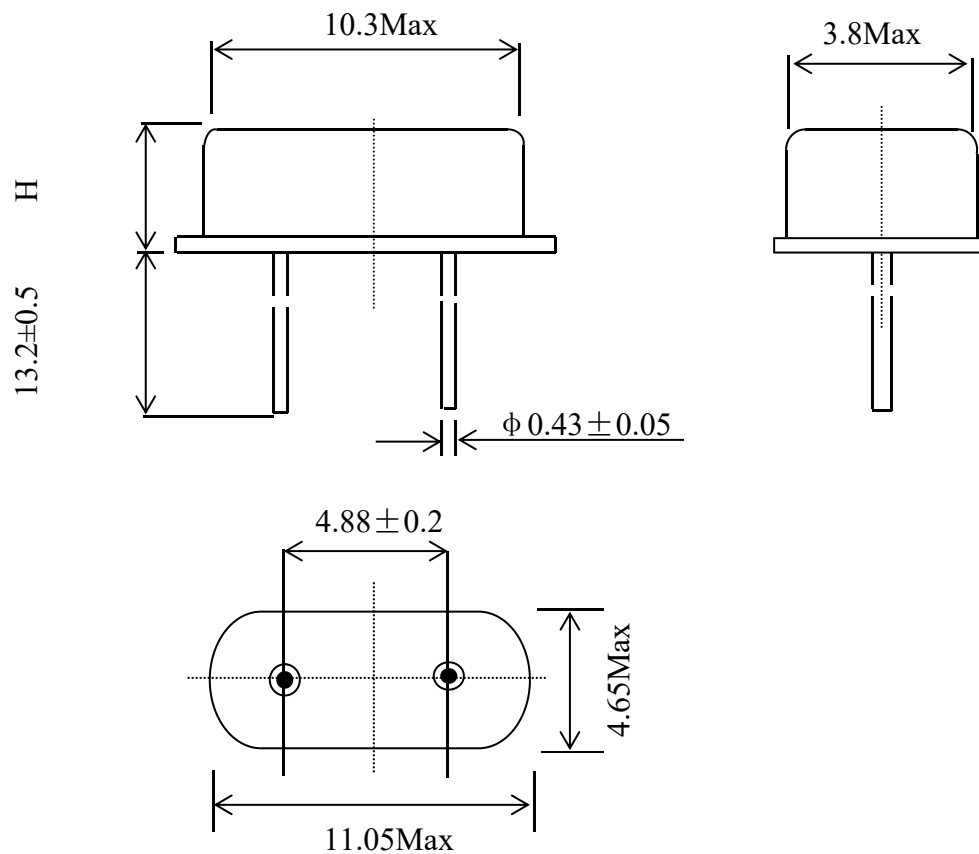

HOLDER	H(Max)
HC-49/S1	2
HC-49/S2	2.5
● HC-49/S3	3.5

4. MARKING

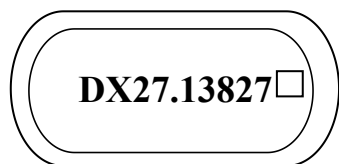

□里面字母代表我司主物料编号, 不一定为固定字母

5. REFLOW PROFILE (49US-SMD/49USS-SMD)

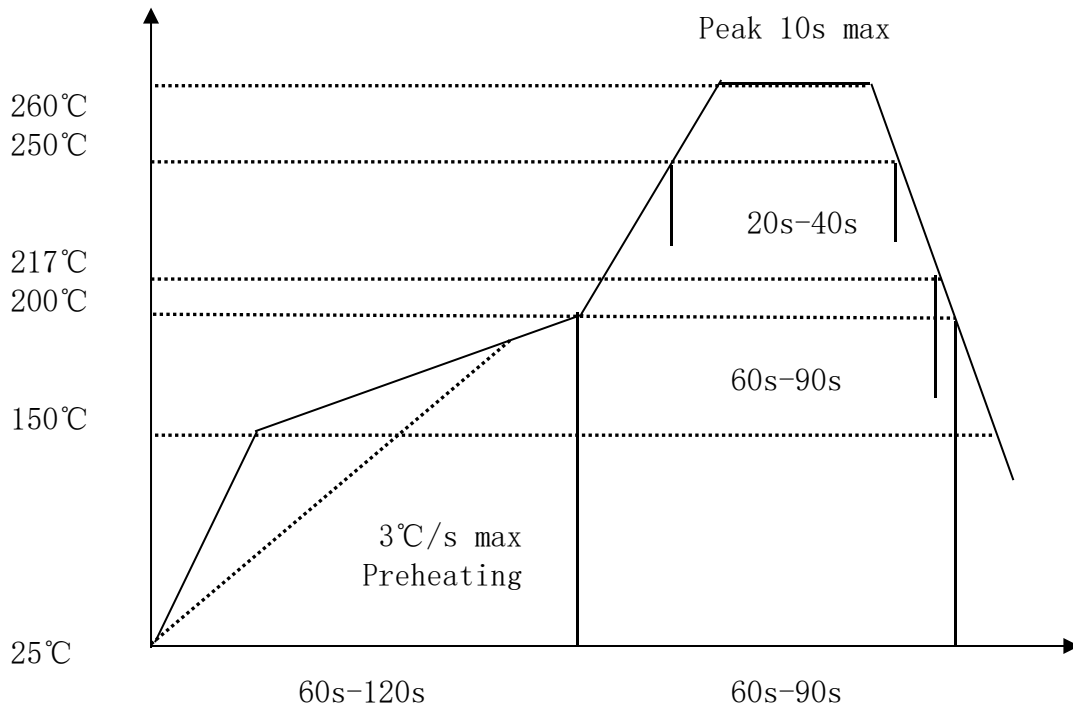

6. CRYSTAL TEST CIRCUIT

TEST SET: KH1120:

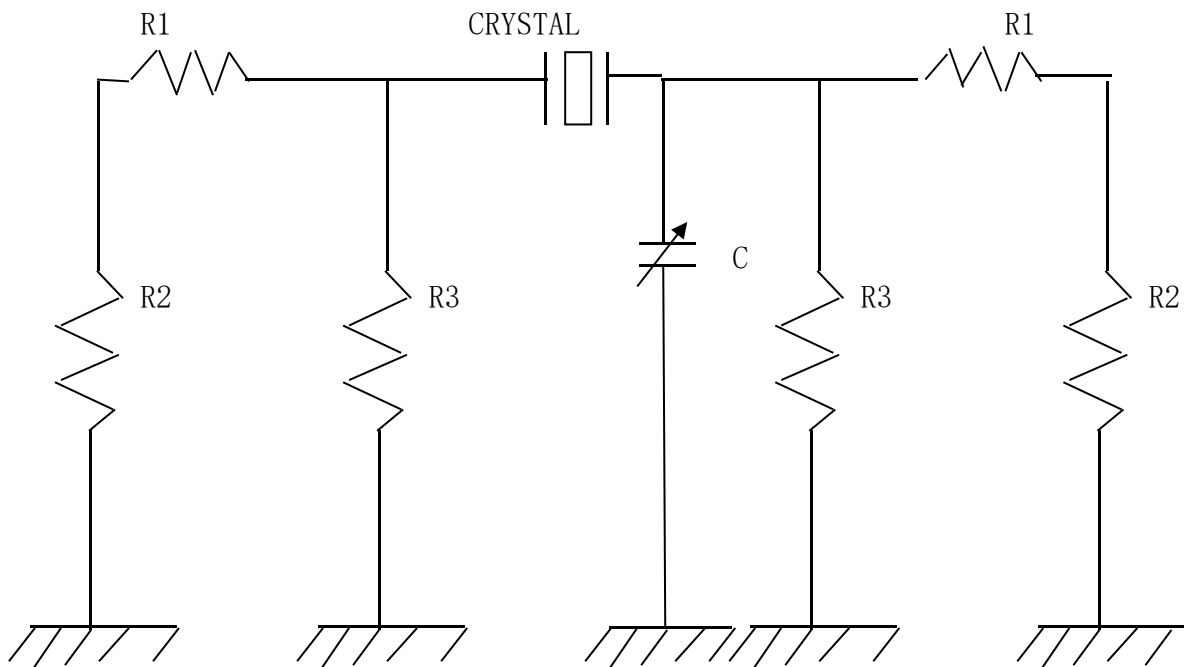

R1: PI_{top} resistor=66.2 Ω
 R2: PI_{outer} resistor=159 Ω
 R3: PI_{inner} resistor=14.2 Ω