

Mounting hole detail

Shaft type

X	L	F
20F7	20	7.0
15F7	15	7.0
12F5	12	5.0
16F7	16	7.0
13.5F7	13.5	7.0
16.5F4	16.5	4.0
20F10	20	10
15F2.5	15	2.5
15.5F5	15.5	5.0

Pulse type

Y	C. C	PULSE
24C24P	24	24
24C12P	24	12
24P	/	24
12P	/	12

				KLS ELECTRONIC CO., LTD				PART NO. L-KLS4-EC12-012424-W	
				SCALE	TOLERANCE	APPROVED	CHECK	DRAW	TITLE
				2/1	less than 10±0.3				开关编码器
				UNIT	above 10-30±0.5				SERIES
				新版发行	above 30-100±1.0				12mm系列
									CAD NO.

1. 一般事项 General

1.1 适用规格 Scope

本规格适用于微小电流回路的电子设备,属12型回转编码器.

This specification applies to 12mm size low-profile rotary encoder(incremental type) for microscopic current circuits,used in electronic equipment

1.2 标准状态 Standard atmospheric conditions

除另外有规定外,测量应在以上状态下进行:

Unless otherwise specified,the standard range of atmospheric conditions for making measurements and test is as following limits:

温度 Ambient temperature: 15°C to 35°C

相对湿度 Relative humidity : 25% to 85%

气压 Air pressure : 86kpa to 106kpa

1.3 使用温度范围

Operating temperature range: -10°C to 70°C

1.4 保存温度范围

Storage temperature range : -40°C to +85°C

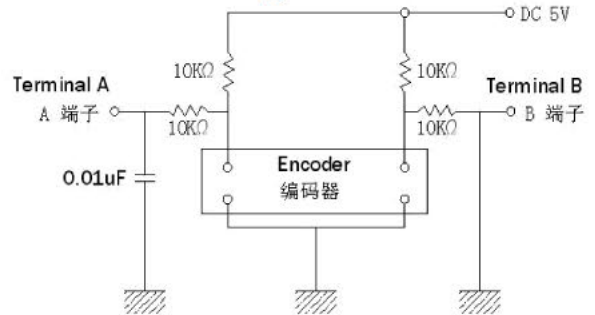

《图1》

2. 构造 Construction

2.1 尺寸 Dimensions

见所附成品图 Refer to attached drawing

3. 额定值 Rating

3.1 额定电压

Rated voltage: DC 5V

3.2 最大额定电流(阻抗负载)

Maximum operating current (resistive load)

各相导线 Each lead: 0.5mA(MAX 5mA; MIN 0.5mA)

公共导线 Common lead: 1mA(MAX 10mA; MIN 0.5mA)

4. Application Nots 使用上的事项

4.1 避免储藏于高温、潮湿及腐蚀的场所,产品购入后尽可能在6个月内使用完.拆包装后未使用完的剩余产品需储存于防潮的环境下.

Avoid storing the products in a place at high temperature,high humidity and in Corrosive gases.Please use this product as soon as possible with 6 months limitation.If any remainder left after packing is opened,please store it with proper moistureproofing, gasproofing etc.

4.2 编码器信号的计算方法应将操作的速度,信号的取样时间及电子回路中的微电脑软体等考虑进去.

The encoder pulses count method should be designed with taking operating speed,sampling time and design of the microcomputer softwae into cosideration.

4.3 此产品在定位点的输出阻抗波形参照(5-1),因此在设计软体时请留意其状态.

With this products the detent position output consnlt fig.5-1.Therefore make the A phase the reference at the soft ware design stage.

4.4 在设计时要考虑到杂讯,建议使用C/R滤波电路(图1).

At design of the pulse count process.Using the C/R filter circuit is Recommended(fig.1).

4.5 本产品请勿碰触到水,可能会导致输出波形的异常.

Care must be taken not to expose this product to water or dew to prevent possible problem in pluses output waveform

EC12 SERIES SPECIFICATION EC12系列规格书

5. 电气性能 ELECTRICAL CHARACTERISTICS

项目 ITEM	条件 CONDITIONS	规格 SPECIFICATIONS
5.1 输出信号 Output signal format	A、B两信号输出相位差,输出波形说细见(图2/3)(虚线表示带卡点位置的上攀子处位置) 2 phase different signals(signal A,signal B)Details shown in(fig.2/3) (the broken line shows detent position.)	
	轴回转方向 Shaft rotational direction	信号 Signal
	顺时针方向 C. W	A(A-C端子间) A(Terminal A-C) B(B-C端子间) B(Terminal B-C)
	逆时针方向 C. C. W	A(A-C端子间) A(Terminal A-C) B(B-C端子间) B(Terminal B-C)
5.2 分解能力 Resolution	回转360°的输出脉冲数. Number of pulses in 360° rotation.	□12个脉冲/360° (图2) 12Pulsrs/360° fig2 for each phase □24个脉冲/360°(图3) 24Pulsrs/360° fig2 for each phase
5.3 开关特性 Switching characteristics	下(图4)所示回路,轴以360°/sec的速度转动测定. Measurement shall be made under the condition aw follows. Shaft rotational speed:360°/S Test circuit:(fig.4)	
	<p align="center">图4(fig.4)</p>	<p align="center">图5(fig.5)</p>
	(注)编码OFF指输出电压3.5V以上的状态(fig.5).Code-OFF area:The area which the voltage is 3.5V or more(fig.5) 编码ON指输出电压1.5V以下的状态(fig.5).Code-ON area:The area which the voltage is 1.5V or less(fig.5)	
5.3.1 振荡 Chattering	编码OFF→ON或ON→OFF时,输出1.5~3.5V 通过时间应符合规定. Specified by the signal' spassage time from 1.5V to 3.5V of each switching position(code OFF~ON or ON~OFF)	$t_1, t_3 \leq 5ms$
5.3.2 滑动杂音 (突跳) Sliding noise (Bounce)	编码ON部分的1.5V以上的电压变动时间在振荡t1,t3之间会产生1ms 以上,1.5V以下的ON部分另外,如果各突跳间1.5V以下的范围在1ms 以上时,则判定为另一个突跳. Specified by the time of voltage change exceed 1.5V in code-ON area. when the bounce has code-ON tie sess than 1ms between chattering (t1 or t3).the voltage change shall be regarded aw a part of chattering. when the code-ON time between 2 bounces is less than 1ms.they are regarded as 1 linded bounce.	$t_2 \leq 3ms$

EC12 SERIES SPECIFICATION EC12系列规格书

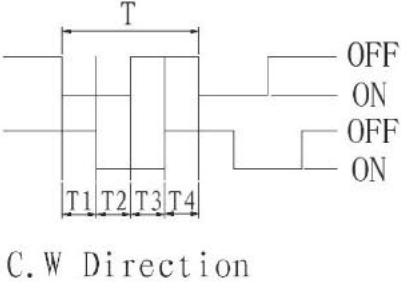
5.电气性能 ELECTRICAL CHARACTERISTICS		
项目 ITEM	条件 CONDITIONS	规格 SPECIFICATIONS
5.3.3滑动噪音 Sliding noise	编码OFF部份的电压变动. The voltage change in code-OFF area.	$\geq 3.5V$ 3.5V min
5.4相位差 Phase difference	<p>下(图6)所示回路,轴以$360^\circ / \text{sec}$的速度转动测定. Measurement shall be made under the condition which the shaft is rotated at 60r/min</p> <p align="center">图6 fig.6</p>  <p>A信号(A C)间 signal A B信号(B C)间 signal B</p>	T1、T2、T3、T4 $\geq 4\text{ms}$ 见图6(fig.6)
5.5绝缘阻抗 Insulation resistance	在端子和轴间施加电压250V DC. Measurement shall be made under the condition which a voltage of 250V DC is applied between individual terminals and bushing.	100M Ω 以上 100M Ω Min
5.6耐电压 Dielectric strength	在端子和轴间施加AC 50V电压1分钟 A voltage of 50V AC shall be applied for 1 minute between individual terminals and bushing	不得有绝缘破坏 Without arcing or breakdown
5.7端子间接触阻抗 Contact resistance	编码讯号处于ON时安定状态条件下测定. Measurement shall be made under condition which a output signal is ON.	$\leq 1\Omega$ 1 Ω Max
6.机械性能 Mechanical characteristics		
6.1全回转角度 Total rotational angle		360°(无止档点) 360°(Endless)
6.2定位点力矩 Detent torque	只适用于附卡点装置 Only suitable for C.C.equipment.	3~20mN.m(30~200gf.cm) Shaft rotatable at -10°C +5°C 但在-10°C +5°C轴勉强可转动
6.3定位点数及位置 Number of detent and position	只适用于附卡点装置 Only suitable for C.C.equipment.	24detents(Step angle:15° $\pm 3^\circ$) □24点定位(间隔角度15° $\pm 3^\circ$)
		12detents(Step angle:30° $\pm 3^\circ$) □12点定位(间隔角度30° $\pm 3^\circ$)
6.4轴的推拉强度 Push-pull strength of shaft	在轴端,沿轴向施加5.1Kg的静负荷推和拉各10秒钟 (产品焊锡固定在PCB上). Push and pull static load of 8Kg shall be applied to be shaft in the axial direction for 10s. (After soldering of the PC board)	轴无破损,回转无异常,电气性能无异常 Without damage or excessive play in shaft. NO excessive abnormality in rotational feeling. And.electrical characteristics and be satisfied.
6.5轴摆动 Shaft wobble	在轴前端5mm处,沿径向瞬间施加50mN.m(500gf.cm)的力. A momentary load of 50mN.m(500gf.cm)shall be applied at the point 5mm from the tip of the shaft in a direction perpendicular to the axis of shaft.	0.7xL/30mm p-p以下(L:指安装平面到轴的柄端的距离) 0.7xL/30mm p-p Max或(L:Distance between mounting surface and measuring point on the shaft)

EC12 SERIES SPECIFICATION EC12系列规格书

6.机械性能 Mechanical characteristics		
项目 ITEM	条件 CONDITIONS	规格 SPECIFICATIONS
6.6轴的回转方向 摆动 Shaft play in rotational wobble	用角度板测定. Testing by angle board.	5° 以下 5° MAX
7.耐久性能 Endurance characteristics		
7.1回转寿命 Rotational life	在无负荷条件下轴以600周/小时速度回转30000周. The shaft of encoder shall be rotated to 30000 cycles at a speed of 600cycles/H without electrical load,after with easurements shall be made.	端子间接触阻抗200Ω 以下. Contact resistance 200Ω MAX. 尚余有轻微定位感 Vibration t1,t3≤5mS振荡t1,t3≤5mS Bounce t2≤5mS突跳 t2≤5mS Detent feeling has to remains
7.2耐湿性 Damp heat	温度40±2℃,湿度90~95%的恒温恒湿槽中放置48小时后,在常温、常湿中放置1.5小时后测试. The encoder shall be stored at temperature of 40±2℃ with relative humidity of 90% to 95% for 48H in a thermostatic chaber.And the encoder shall be subjected to standard atmospheric conitions for 1.5H After which measurements shall be made.	所有项应满足初期规格 Specifications in clause all items is shall be satisfied.
7.3耐热性 Dry heat	温度80±3℃的恒温箱中放置48小时,然后在常温、常湿放置1.5小时后测试. The encoder shall be stored at temperature of 80±3℃ for 48H in a thermostatic chamber.And the encoder shall be subjected to standard atmospheric condetions for 1.5H,After which measurements shall be made	所有项应满足初期规格 Specifications in clause all items is shall be satisfied.
7.4低温特性 Cold	温度-25℃±3℃的恒温箱中放置48小时,常温、常湿放置1.5小时后测试. The encoder shall be stored at temperature of -25℃±3℃ for 48H in a thermostatic chamber.And the encoder shall be subjected to standard atmospheric condetions for 1.5H,After which measurements shall be made	所有项应满足初期规格 Specifications in clause all items is shall be satisfied.
7.5焊锡性 Solder ability	端子在235℃±5℃温度的焊锡槽内浸锡3±0.3秒. The terminals shall be imersed into solder bath at 235℃ for 3±0.3s in the same manner as para.	浸锡面积须有75%以上焊锡附着 A new uniform coating of solder shall cover 75% minimum of the surface being immersed.
7.6耐焊接热 Resistance to Soldering heat	手工焊接 Manual soldering 温度300℃以下,时间3秒以内. Bit temperature of soldering iron:300℃ less than application time of slodering iron:within 3s 槽焊 Dip soldering 使用基板:T=1.6mm的单面覆铜板. Printed wiring board:single-stded copper clad laminate board with thickness of 1.6mm.	不得有绝缘体的破坏、变形、接触无异常. Electrical characteristics shall be satisfied No mechanical abnormality

EC12 SERIES SPECIFICATION EC12系列规格书

7.耐久性能 Endurance characteristics		
项目 ITEM	条件 CONDITIONS	规格 SPECIFICATIONS
7.6耐焊接热 Resistance to Soldering heat	预热:基板表面温度100℃以下,时间1分钟以内. Preheating: 1.Surface teperature of board:100℃ or less 2.preheating time:within 1 min. 焊接:温度235±5℃或以下,时间3秒以内 Soldering:Soeier teperature:235±5℃ or less Immersion time:within 3s	不得有绝缘体的破坏、变形、接触无异常。 Electrical characteristics shall be satisfied No mechanical abnormality

推动开关部分 Push Switch Portion
 备注:以下规格适用于**EC12**编码带开关系列。
 No:The following specification is only suitable for the one type with construction of EC11 encoder series.

1.额定值 Rating

1.1额定电压 Rated voltage: DC 5V
1.2最大额定电流(阻抗负载) Maximum operating current(resistive load):10mA MAX.

2.电气性能 Electrical Characteristics

项目 ITEM	条件 CONDITIONS	规格 SPECIFICATIONS
2.1接触电阻 Contact resistance	用DC 5V 10mA电压测定 Voltage test at DC 5V 10mA.	100mΩ or less ≤100mΩ
2.2绝缘阻抗 Insulation resistance	在端子和安装板间施加电压250V DC. Measurement shall be made under the condition which a voltage of 250V DC is applied between individual terminals and bushing and plank.	100MΩ 以上 100MΩ Min
2.3振荡 Bouncing	以1秒钟1往返(OFF-ON-OFF)按压动作。 Shaft shall be push at 1 cycles/s(OFF-ON-OFF).	10ms or less ≤10ms
2.4耐电压 Dielectric strength	在端子和安装板间施加AC50V 电压1分钟 A voltage of 50V AC shall be applied for 1 minute between individual terminals and bushing and plank.	不得有绝缘破坏 Without arcing or breakdown

3.机械性能 Mechanical characteristics

3.1开关电路.接点数 Switch circuit and number of pulse		单极单投(按压ON) Single pole and single throw (PUSH ON)
3.2开关动作力 Operation fore of switch	在轴端,沿轴向施加的按压力。 Push static load to the shaft in the axial direction	200~800gf.cm
3.3开关动移动量 Travel of switch		0.5±0.3mm

4.耐久性能 Endurance Characteristics

按压寿命 Push life	The shaft of encoder shall be push to 20000 cycles at a speed of 600 cycles/H without electrical load,after with measurements shall be made. 在无负荷条件下轴以600次/小时速度按压往返20000周。	接触电阻:≤200mΩ 其它应满足初期规格。 Contact resistance:200mΩ or less
-------------------	---	---