

Mechanical Dimensions

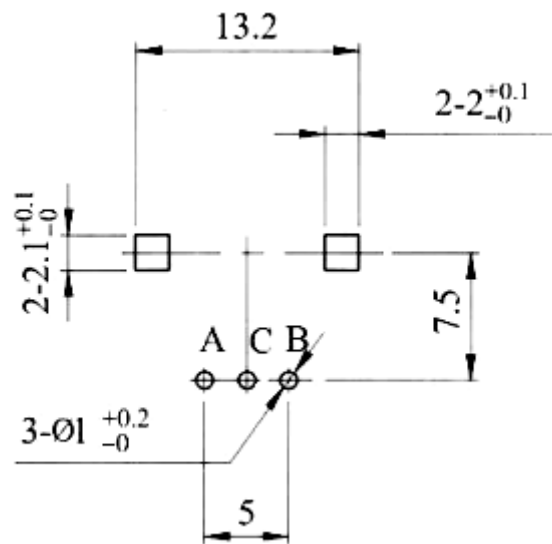
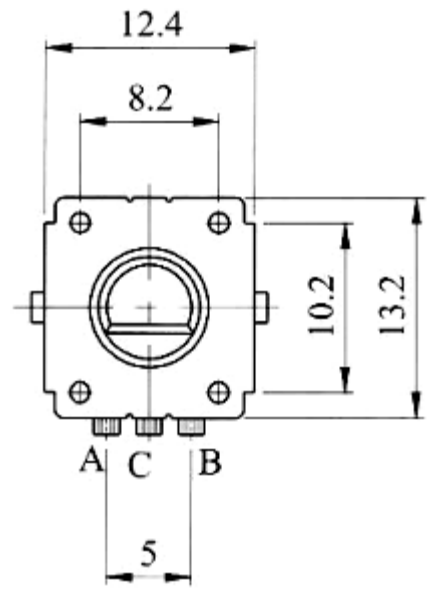
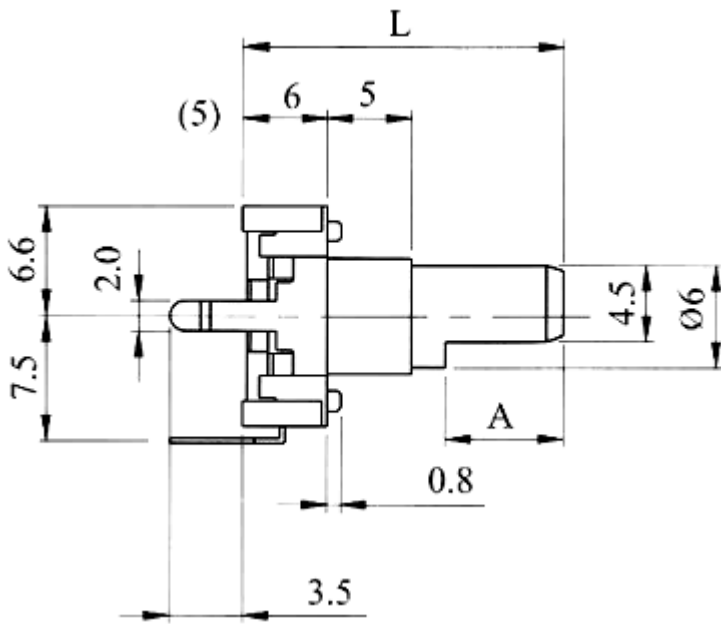

L	20	25	30
A	7	12	12

TOLERANCES UNLESS OTHERWISE	
BASIC DIMENSLONS	TOLERANCES
UP TO 10	±0.3
ABOVE 10 TO 30	±0.5
ABOVE 30 TO 100	±1.0
ANGULAR DIMENSION	±5°

		APPRO	CHECK	DESIGNER
MODEL NO	ALPS K			
DESCRIPTION	Encoder			