

参数规格(PRODUCT SPECIFICATION)

A. 一般规格(General Specification)

| 项目(ITEMS) | 性能(DESCRIPTION) | | |
|-----------------------------------|--|--|--|
| 规格型号/Model No | SA17251H2BW-H | | |
| 尺寸/Dimension | 172×150×51mm | | |
| 马达形式/Motor Type | <input checked="" type="checkbox"/> 罩极式马达 (Shaded Pole Induction Motor) | <input type="checkbox"/> 电容式马达 Capacitor-Run Ind.Motor | |
| 转子形式/Rotor Type | <input checked="" type="checkbox"/> 内转子 (Internal rotor motor) | <input type="checkbox"/> 外转子 (External rotor motor) | |
| 扇 框/Fan Case | 铝合金(Aluminum Alloy) | 黑色喷涂 (Black painting) | |
| 扇 叶/Fan Blade | Thermoplastic PBT | 5 Blades | |
| 转动方向/Direction of Rotation | 顺时针(clockwise) 标签面 Label Side | | |
| 电 压/Voltage | 200~240(VAC) | | |
| 启动电压/Starting Voltage | 165(VAC) | | |
| 频 率/Frequency | 50(Hz) | 60(Hz) | a. 额定电压 / Rated Voltage b. 25℃ c. 65% RH d. Measured after 5 mins e. 风洞测试仪/PQ Measurement Apparatus : (LW9266-SR) f. 标准/Standard : AMCA |
| 转 速/Speed | 2600(rpm) | 2800(rpm) | |
| 运转电流/Current | 0.24(A) | 0.21(A) | |
| 输入功率/Input Power | 53.0(W) | 47.0(W) | |
| 锁定电流/Locked Rotor Current | 0.60(A)MAX | 0.58(A)MAX | |
| 最大风量/Max. Air Flow | 150(CFM) | 185(CFM) | |
| 最大静压/Max. Static Pressure | 0.59(Inch-H ₂ O) | 0.67 (Inch-H ₂ O) | |
| 运转噪音/Noise Level | 51(dB) | 55(dB) | |
| 绝缘阻抗/Insulation resistance | 500V 直流电 (500Megohms minimum at DC500V) | | |
| 绝缘耐压/Dielectric Withstand Voltage | 1800V 交流电 1 秒 (AC1800 V for one second) | | |
| 绝缘等级/Insulation Class | E 级(Class E) | | |
| 轴 承/Bearing | <input checked="" type="checkbox"/> 双滚珠轴承 (Dual Ball Bearing) <input type="checkbox"/> 含油轴承 (Sleeve Bearing) | | |
| 使用寿命/Life Expectation | 常温常湿 40000 小时 (40000h at 40℃, 60%) | | |
| 导 线/Lead Wire | 引线 Lead wire | | |
| 重 量/Weight | 880(g) | | |
| 特殊功能/Special Function | No | | |
| 安规认证/Safety Certificate | CE, UL | | |

B. 商标 (Label Marking)

| | | |
|--|--------------------|---------------|
| | 型号/Model No | SA17251H2BW-H |
| | 额定电压/Rated Voltage | 220VAC |
| | 额定功率/Rated Power | 47/53 (W) |
| | 标签尺寸/Label Size | Φ70mm |
| | 商标颜色/Labe Color | Blue |
| | 安规/Safety | CE, UL |
| | 附加码/Appendix Code | No |

C. 外框尺寸 (Outline Dimension)

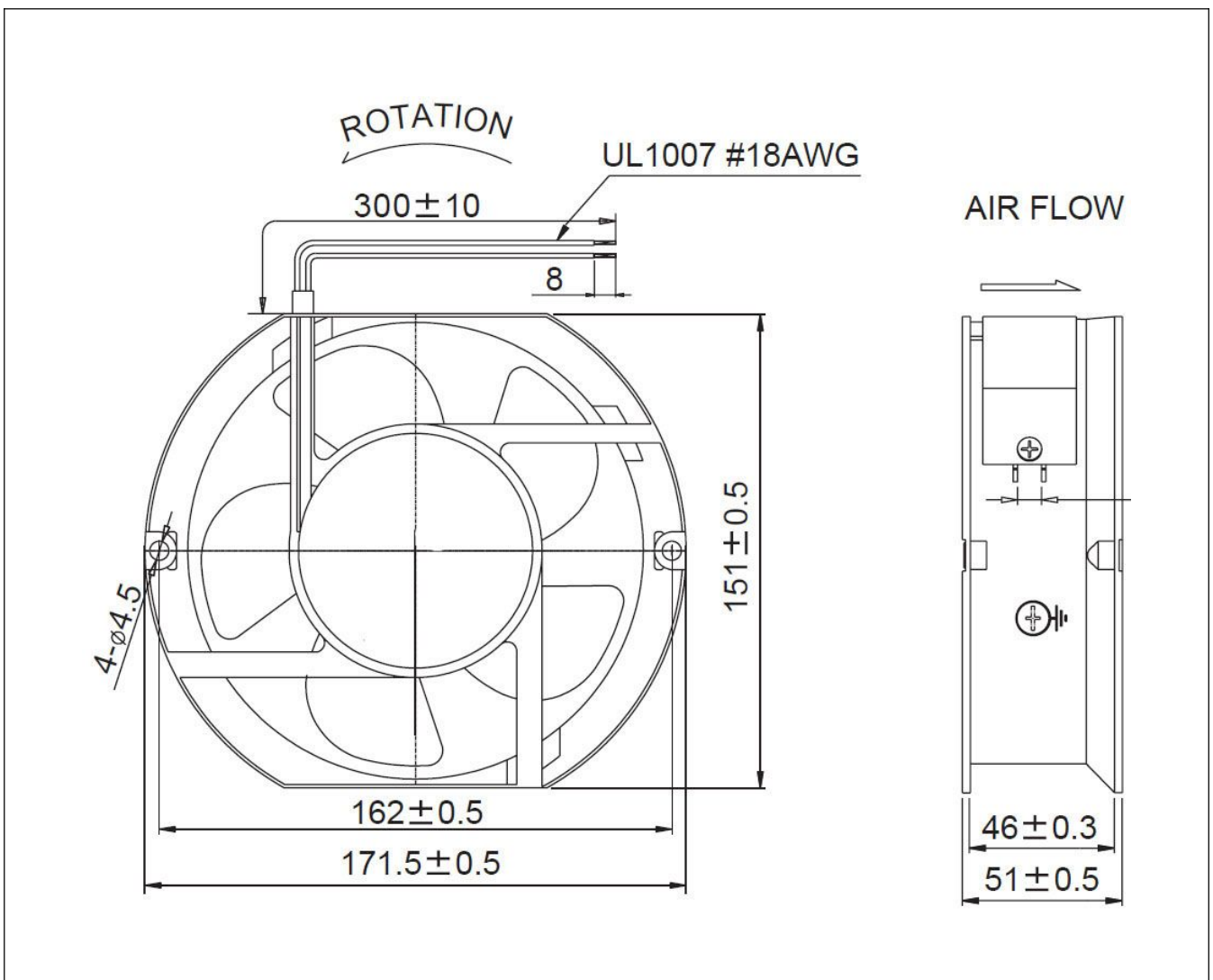

Note:

1. We will not guarantee the products if your application exceeds the limitations outlined in this specification.
2. Please do not touch and push fan blade with fingers or others. Fan blade and ball bearings may be damaged. And it caused noise defect.
3. Please avoid operating YIMENG's products in poisonous material (organic, cyanogens, formalin, phenol, etc.) or corrosive gas environment (H_2S , SO_2 , NO_2 , etc.)
4. We do not warrant performance safety against accidents caused by dust, water, droplets dew, bugs, etc.
5. Always ensure that fans are stored according to the storage temperatures specified. Do not store in a high humidity environment. If the fans are stored for more than 6 months, we recommend functional testing before using.
6. Please do not damage this product including coil and lead wires while installing or wiring. There may be smoking or fire.
7. Avoid the damage, check the correct voltage and proper polarity before connecting with power.
8. Improper mounting may cause harsh resonance, vibration, and noise. Please mount securely.
9. It is very important to notify that avoid to drop from 60cm height when in any movement or operation, it will impact the balance of blade. Especially ball bearing structure is avoided to drop down.
10. Safety is a top priority. Please furnish guard accessories to prevent injury to personnel