

## Mylar Speaker Specification

Our Part No		L-KLS3-3606-R8W1	
Size	Diameter 36mm	Total Height	5.0 mm
No.	Item	Specification	Testing Condition
1.	Rated Imp	8ohm $\pm$ 15%	At 1 kHz 1.0V
2.	Resonance Freq	480Hz $\pm$ 20%	Without Baffle
3.	Output S.P.L.	83 $\pm$ 3dB	At 1m 1W 600,800,1K, 1.2KHz Average
4.	Input Power	Rated Power: 0.5W	Max Power: 1.0W
5.	Frequency Range	F0---12KHz	Output S.P.L. -10dB
6.	Operation	Must Be Normal	Program Source: 0.5W
7.	Buzzes & Rattles	Must Be Normal	Sin Wave 2.0V
8.	Load Test	After Test Meet 2&7	0.5W 96hours White Noise
9.	Distortion	5% Max	0.5W 1000Hz
10.	Heat Test	After Test 7&8&9	55°C $\pm$ 2°C 16hours
11.	Cold Test	After Test 7&8&9	-20°C $\pm$ 3°C 16hours
12.	Humidity	After Test 7&8&9	40°C $\pm$ 2°C 90~95% R.H. 48hours
13.	Insulation Resistance	1M $\Omega$	Dc100v FRA. And TER.
14.	Magnet	$\varnothing$ 12.5 $\times$ 1.0	N35
15.	Net Weight	7.0g/PC	
16.	Polarity		

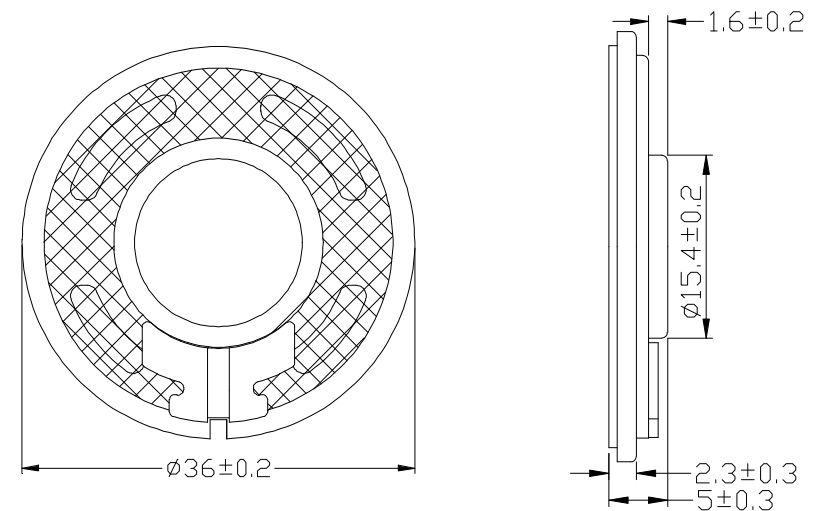
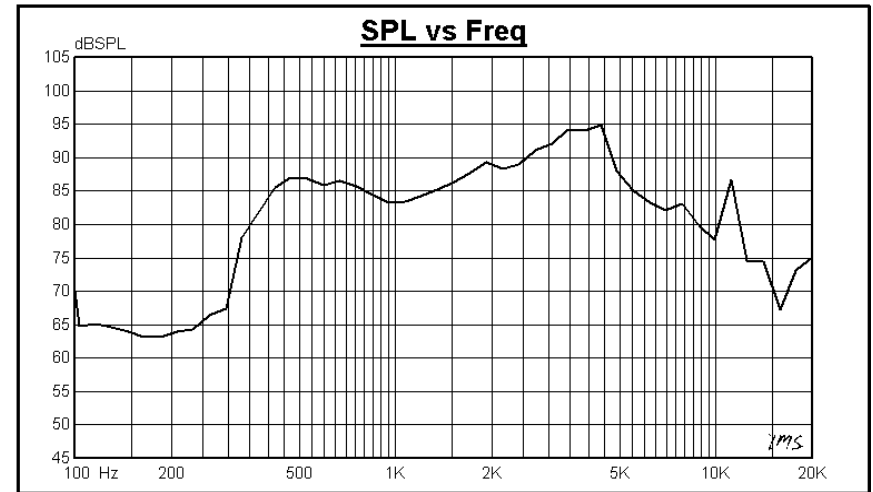

NINGBO KLS ELECTRONIC CO; LTD