

承認書

SPECIFICATION FOR APPROVAL

客戶(Customer): _____
客戶料號(Customer P/N): _____
機種編號(Files No.): FS2015-12-027
機種型號(Model No.): RB-50090802
品名(Description): SPEAKER(RoHS)
規格(Specification): 8Ω 0.5W

客戶承認欄 (Customer Authorization Signature)	供應商 (Supplier Audit)		
	Approver	Checker	Author
			卢丽珍
日期: 2015 年 12 月 17 日			

Revision History

Version	Date	Description	Author
A0	December 17, 2015		卢丽珍

东莞市富新电子有限公司

DONGGUAN FUXIN ELECTRONIC CO., L.T.D.

中國 廣東省 东莞市 企石镇 东山管理区 永盛工业园

Dong Shan Guan Li Qu, Qi Shi Town, Dong Guan City, Guang Dong, China

TEL: +86(0)769-8657 2629 FAX: +86(0)769-8657 2621

<http://www.ruibocn.com>

DONGGUAN FUXIN ELECTRONIC CO., L.T.D.

东莞市富新电子有限公司

Dong Shan Guan Li Qu, Qishi Town, Dong guan City, Guangdong CHINA.

中國 廣東省 东莞市 企石镇 东山镇 永盛工业园

TEL: (86-769) 86572629 FAX: (86-769) 86572621

SPECIFICATION

Above Measuring condition under temperature : 25~35°C R.H. 25 ~75%. According to standard GB/T9396-1996

	Model	RB-50090802		
1	Type	Dynamic Speaker		
2	Dimension	Outline Dimension Shall Be As Shown In Fig(1).		
3	Weight	Approx 13.2 Grams.		
4	Magnet	Material	Nd-Fe-B	
5	Impedance	8 ± 15% Ohm at 1000Hz. 1V		
6	Power Rating	Normal	0.5W	Maximum 1.0W
7	FO	600±20% Hz		
8	S.P.L.	98±3dB/0.5Watt 0.1Meter. Average At 1000,1200,1500,2000Hz.		
		Measurement Method Shown In Fig(2).		
9	Frequency Range	F0~10,000Hz.Average SPL 10dB. Frequency Response Fig (3).		
10	Distortion	10% Maximum At 1000Hz 0.5W.		
11	Abnormal Sound Test	Must be Normal Tested by 2.0 Volts. Sine wave for50~5kHz		
12	Polarity	Diaphragm Shall Move Forward When Apply a Positive DC.		
		Red "+" or "Marked" Terminal		
13	Operating Temperature	-25°C to +65°C		
14	Storage Temperature	-25 °C to +65 °C		

15	Reliable Test	After any following test leave speakers at room temperature for 1 hour, SPL shall not deviate by ± 3 db from initial value		
15-1	Load Test	white noise for 96 hours at 0.5 W input power.		
15-2	High Temperature Test	+65±2 °C 96hours		
15-3	Low Temperature Test	-25±2 °C 96hours		
15-4	Humidity Test	+40±2 °C relative humidity 90~95%R.H 96hours		
15-5	Vibration Test	Frequency 30 ± 15 Hz, Amplitude 1.5 mm for 2 Hours per axis(x. y. z axis)		
15-6	Temperature Cycle test	-25~ + 65 °C 5 Cycles Temperature test.		

DATE	SPEC.NO	Version	Page
December 17,2015		A0	2/5

DONGGUAN FUXIN ELECTRONIC CO., L.T.D.

东莞市富新电子有限公司

Dong Shan Guan Li Qu, Qishi Town, Dong guan City, Guangdong CHINA.

中國 廣東省 东莞市 企石镇 东山镇 永盛工业园

TEL: (86-769) 86572629 FAX: (86-769) 86572621

SPECIFICATION

Model : RB-50090802

16: Drawing(Fig1) Unit: mm Tolerance:±0.3mm

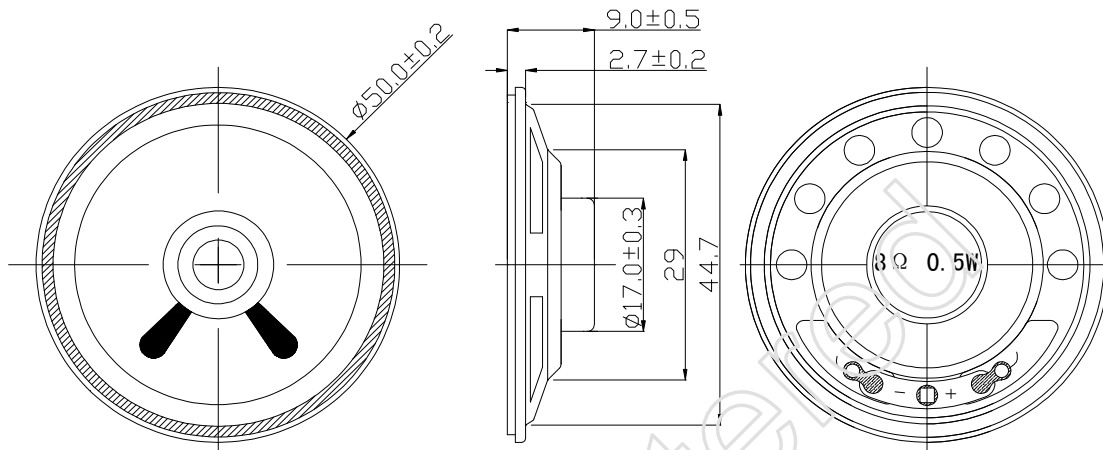

17. Speaker Construction

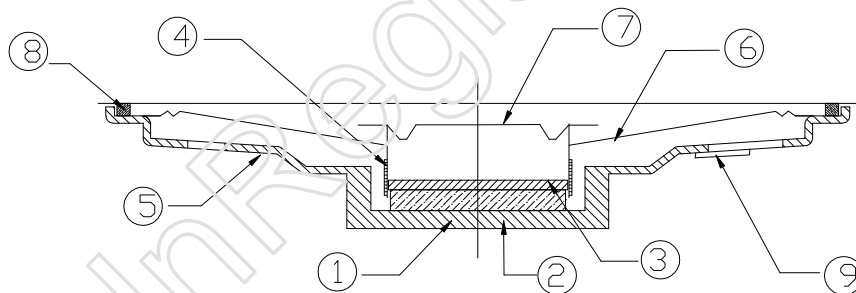

NO	PART NAME	MATERIAL	Q'TY
1	YOKE	SPCC	1
2	MAGNET	Nd-Fe-B	1
3	WASHER	SPCC	1
4	VOICE COIL	CCAW	1
5	FRAME	SPCC	1
6	DIAPHRAGM	PAPER	1
7	CAP	PAPER	1
8	GASKET	PAPER	1
9	TERMINAL	P.C.B	1

DATE	SPEC.NO	Version	Page
December 17,2015		A0	3/5

DONGGUAN FUXIN ELECTRONIC CO., L.T.D.

东莞市富新电子有限公司

Dong Shan Guan Li Qu, Qishi Town, Dong guan City, Guangdong CHINA.

中國 廣東省 东莞市 企石镇 东山镇 永盛工业园

TEL: (86-769) 86572629 FAX: (86-769) 86572621

SPECIFICATION

18.Measurement Method Fig(2).

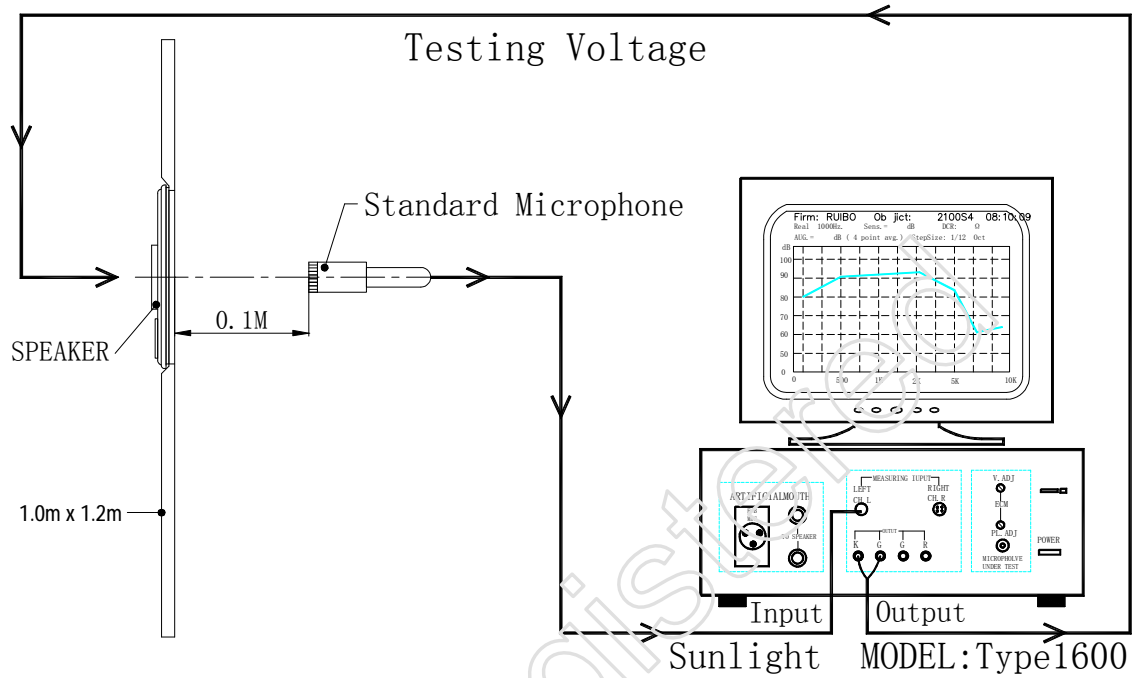

19. Test baffle Diagram

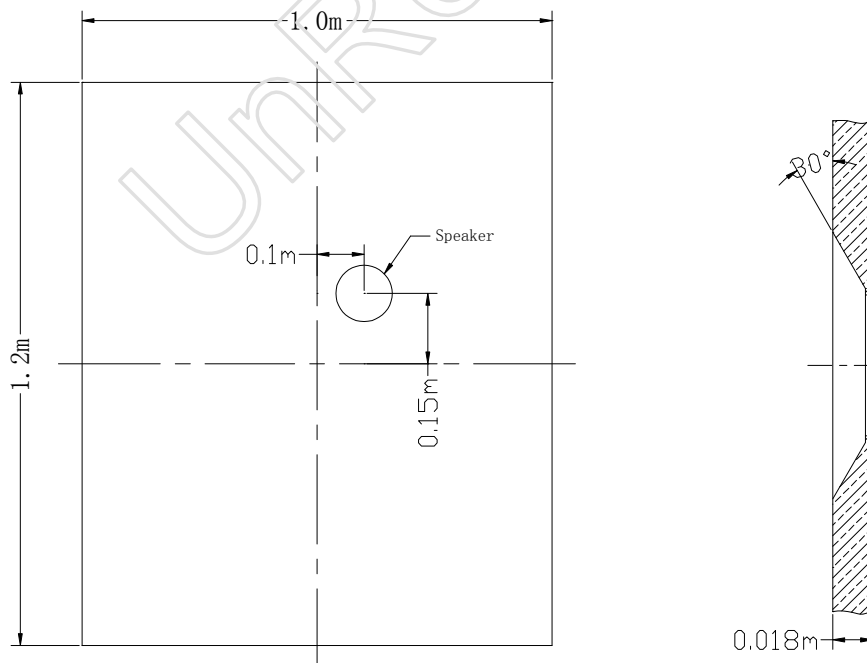

DATE	SPEC.NO	Version	Page
December 17,2015		A0	4/5

DONGGUAN FUXIN ELECTRONIC CO., L.T.D.

东莞市富新电子有限公司

Dong Shan Guan Li Qu, Qishi Town, Dong guan City, Guangdong CHINA.

中國 廣東省 东莞市 企石镇 东山镇 永盛工业园

TEL: (86-769) 86572629 FAX: (86-769) 86572621

SPECIFICATION

20. Frequency Resonance Fig (3).

Firm:460 Model:BOX DATE:12-18-2015 TIME:09:59:22
 Real 1000Hz Sens.= 90.0 dB SPL Pass F.R.: Pass DCR: 8.0Ω Pass
 Average SPL= 90.0 dB SPL Pass (1000;1200;1500; 2000Hz) Sweep Speed: 1/12 Oct.

Att. @ +0dB N 1.10
Loudspeaker Frequency Response Test Test distance : 0.10M

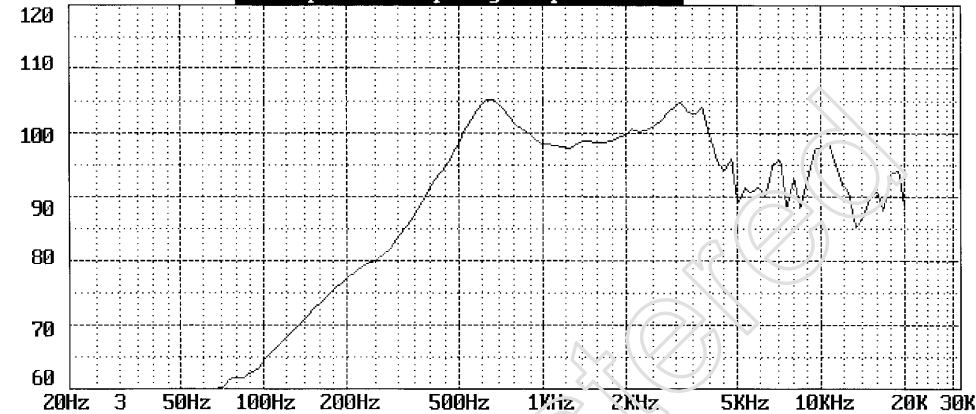

Voltage applied for **F.R.** = 2.000V **Start F.** = 20Hz **Stop F.** = 20000Hz
 F.R. check: None

21. AC Impedance curve

Firm:460 Model:BOX DATE:12-18-2015 TIME:09:51:53
 Start Freq. = 20Hz Stop Freq. = 10000Hz Sweep Speed: 1/12 Oct.
 ACV = 1.000V ACZ = 9.36 Ω @ 1000Hz. (Real)
 Fo = 598Hz; Qm = 7.39; Qe = 12.02; Qt = 4.58; DCR = 7.92Ω.

N 1.10

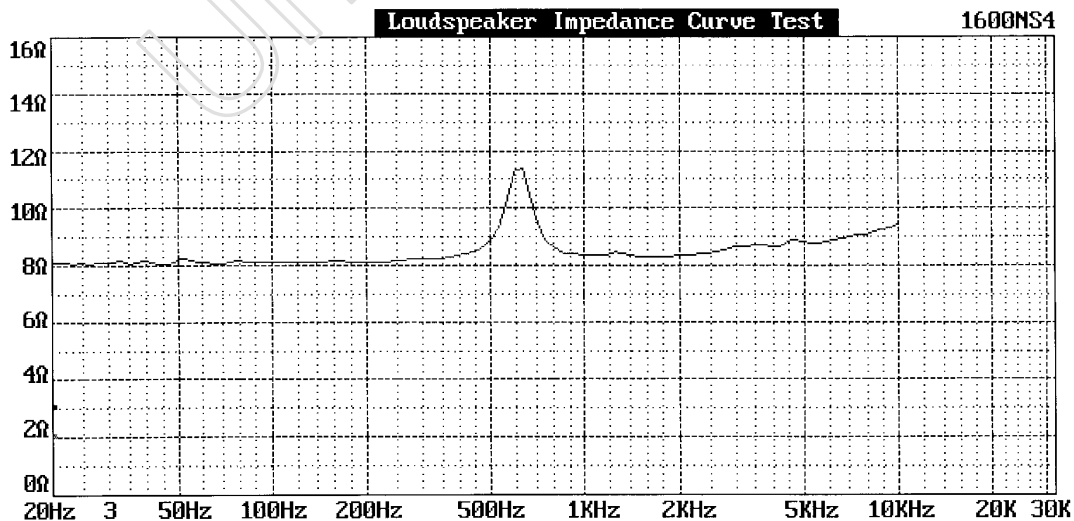

DATE	SPEC.NO	Version	Page
December 17,2015		A0	5/5