

Product Specification

Number: L-KLS7-046-101021BB

Name: Rocker switch

Customer: A05

Date: 2023-12-08

Customer Signature:

--



NINGBO KLS ELECTRONIC CO; LTD

Tel : 0086-574-86828566

Fax : 0086-574-86824882

ADD : NO. 8-1, RONGXIA RD. XIAPU SHANQIAN
INDUSTRIAL ZONE BEILUN NINGBO ZHEJIANG.

Compi	Check	Review	Approva
Jenny	Jack.C		

NINGBO KLS ELECTRONIC CO; LTD WWW.KLSELE.COM			文件类型 TYPE OF FILE	规格书 SPECIFICATION	
			L-KLS7-046-101021BB		
产品系列 SERIES	跷板开关 ROCKER SWITCH	产品型号 TYPE	系列	页次 PAGE	1 of 4
发布日期 ISSUED DATE	2023-12-08	修正日期 AMENDED DATE	KLS7-046	版本 VERSION	A0

1、温度范围

Temperature range

1.1 使用温度范围： -25 °C ~85 °C

Temperature range for use -25 °C ~85 °C

2、测试环境条件：

Test circumstance condition:

环境温度： 25 °C±10 °C

Ambient temperature : 25 °C±10 °C

相对湿度： 45%~85%

Relative humidity : 45%~85%

空气压力： 102 千帕

Air pressure: 102KPa

3、外观、结构和尺寸

Appearance 、 structure and dimension

3.1 外观：

Appearance:

外观美观、没有生锈、伤痕、电镀不良、破裂，剥离现象。动作正常，换位清晰。

Nice appearance, free from rust, scar, bad plating, denude, normal action, clear conversion.

3.2 结构和尺寸：

Structure and Dimension:

参照有关外形图

Reference to the relative

4、额定值： CQC CE: 3A 250V AC

6A 125V AC

Rating: CQC CE: 3A 250V AC

6A 125V AC

NINGBO KLS ELECTRONIC CO; LTD WWW.KLSELE.COM				文件类型 TYPE OF FILE	规格书 SPECIFICATION
				L-KLS7-046-101021BB	
产品系列 SERIES	跷板开关 ROCKER SWITCH	产品型号 TYPE	系列	页次 PAGE	2 of 4
发布日期 ISSUED DATE	2023-12-08	修正日期 AMENDED DATE	KLS7-046	版本 VERSION	A0
项目 Item	测试条件 Test Condition			规格 Performance	
5、机械性能 Mechanical Performance					
5.1	动作力 Operating Force	开关垂直于操作方向放置，在按钮一侧逐渐施力，测量开关导通所需的最大力度。 Vertical placing the switch with the direction of switch operation, then gradually increasing the force, measure demanded maximum force that switch continuity.		依图所示	
5.2	端子强度 Terminal strength	在端子的顶部施加一向内推的 60N 静负荷，持续 60 秒。 Enforce push-inward static 60N load on the top of terminal, lasting 60 seconds		端子无损伤，脱落，开关功能动作正常。 No damage, leafing, switch function action is normal.	
5.3	可焊性试验 Solder-Ability	将端子浸入熔融的锡槽内，温度为 235±5℃，时间为 3±0.5 秒。 Immerse the terminal to the molten solder tank, temperature reach to 235±5℃,time reach to 3±0.5 seconds		浸入的部分 90% 以上表面被锡覆盖。 90% of the surface will be covered by solder.	
5.4	耐焊性试验 Soldering resistance test	端子的焊接部分浸入温度为 260±5℃ 熔融的锡炉内 3±0.5 秒。 The welding part of terminal immerse molten solder at a temperature of 260±5℃ for 3±0.5 seconds. 手工烙铁焊接：焊接温度 350±5℃，焊接时间 3±0.5 秒。焊接时在端子上不能施加异常压力。 Manual iron welding: welding temperature: 350±5℃,welding time: 3±0.5 seconds. When welding, can't enforce anomaly pressure on the terminal.		本体无变形，能满足于机械、电气性能 Without deformation of base, can satisfy mechanical, electronic performance.	

NINGBO KLS ELECTRONIC CO; LTD WWW.KLSELE.COM			文件类型 TYPE OF FILE	规 格 书 SPECIFICATION	
			L-KLS7-046-101021BB		
产品系列 SERIES	跷板开关 ROCKER SWITCH	产品型号 TYPE	系列	页次 PAGE	3 of 4
发布日期 ISSUED DATE	2023-12-08	修正日期 AMENDED DATE	KLS7-046	版本 VERSION	A0
项目 Item		测试条件 Test Condition		规 格 Performance	
6、电气性能 Electronic Performance					
6.1	接触电阻 Contact resistance	在 1KHz 小电流下测量。 Being measured at 1KHz small current.		50 毫欧姆以下 50mΩ MAX.	
6.2	绝缘电阻 Insulation resistance	在端子之间和端子与外壳之间施加 DC500V，一分钟后测量。 Measurement shall be made enforcing DC500V between terminals and between terminals and frame for 1 minute.		100 兆欧姆以上 100MΩ MIN.	
6.3	耐电压 Withstand voltage	在极与极之间施加 AC1500V，0.5mA、1min，在极与操动件之间施加 AC1000V，0.5mA 1min。 Enforce AC1500V, 0.5mA between pole and pole in 1min ,enforce AC1000V, 0.5mA between pole and frame in 1min		无击穿现象出现。 No breakdown.	
7、耐久性能 Durability					
7.1	机械寿命 Mechanical life	每分钟 30 次的速度连续工作 100000 次 Operating 100000 cycles at a rate of 30cycles per minute		外观，动作功能正常	
7.2	电气寿命 Electrical life	额定负载条件下,每分钟 30 次的速度操作 ≥ 10000 次.工作条件: 6A 250VAC Operating ≥ 12000 cycles at a rate of 30cycles per minute under rate loading on conaition that the voltage is 250VAC and the current is 6A		1.耐电压≥1500VAC/1min Withstand voltage ≥1500VAC/1 min	

NINGBO KLS ELECTRONIC CO; LTD WWW.KLSELE.COM				文件类型 TYPE OF FILE	规格书 SPECIFICATION
				L-KLS7-046-101021BB	
产品系列 SERIES	跷板开关 ROCKER SWITCH	产品型号 TYPE	系列	页次 PAGE	4 of 4
发布日期 ISSUED DATE	2023-12-08	修正日期 AMENDED DATE	KLS7-046	版本 VERSION	A0
项目 Item	测试条件 Test Condition			规格 Performance	
8、耐候性 Weather Ability					
8.1	耐高温试验 Heat test	在 $85\pm 2^{\circ}\text{C}$ 环境中放置 72 小时，再放在正常环境中 60 分钟后进行测试。 Putting at $125\pm 2^{\circ}\text{C}$ for 72 hours. Test after keeping in normal condition for 60 minutes.			
8.2	耐湿试验 Anti-humid test	在温度为 $40\pm 2^{\circ}\text{C}$ ，相对湿度为 91%–95%RH 的环境中放置 96 小时，再放在正常环境中 60 分钟后进行测试。 Putting at $40\pm 2^{\circ}\text{C}$ ，91%~95%RH for 96 hours. Test after keeping in normal condition for 60 minutes.		1、接触电阻 50 毫欧以下 Contact resistance 50mΩ MAX. 2、绝缘电阻 100 兆欧以上 Insulation resistance 100MΩ MIN.	
8.3	耐低温试验 Anti-low temperature test	在 $-25\pm 3^{\circ}\text{C}$ 的环境中放置 16 小时，再放在正常环境中 60 分钟后进行测试。 Putting at $-25\pm 3^{\circ}\text{C}$ for 16 hours. Test after keeping in normal condition for 60 minutes.		3、耐电压 1500VAC, 0.5mA、5S 无击穿 Withstand voltage 1500VAC, 0.5mA, 5S No breakdown.	
8.4	温度交变试验 Temperature cycling test	在如图示之环境中，循环 5 次后，再置于正常环境中，30 分钟后进行测试。 In FIG. For 5 cycles, test after kept in normal condition for 30 minutes.		4、无任何迹象显示机械及电气性能之损坏 No sign of damage mechanical and electronic performance.	

标记 ▲	日期	姓名	变更内容
---------	----	----	------

NO.	名称 NAME	数量/Q' TY
1	基座 Housing	1
2	按钮 Rocker	1
3	中角 Terminal	1
4	边角 Terminal	1
5	内套 endotheca	1
6	跷板 rocker	1
7	扭簧 Torsional spring	1
8	圆铁套 Round iron set	1

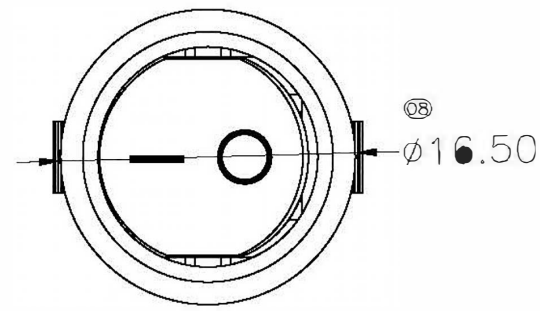
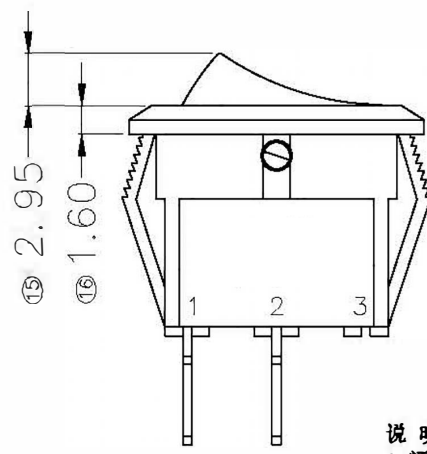
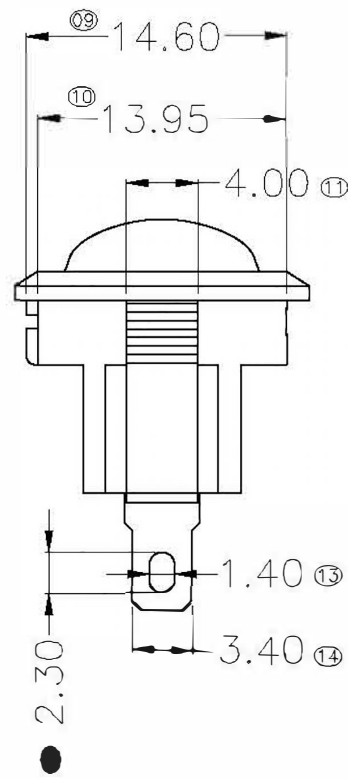
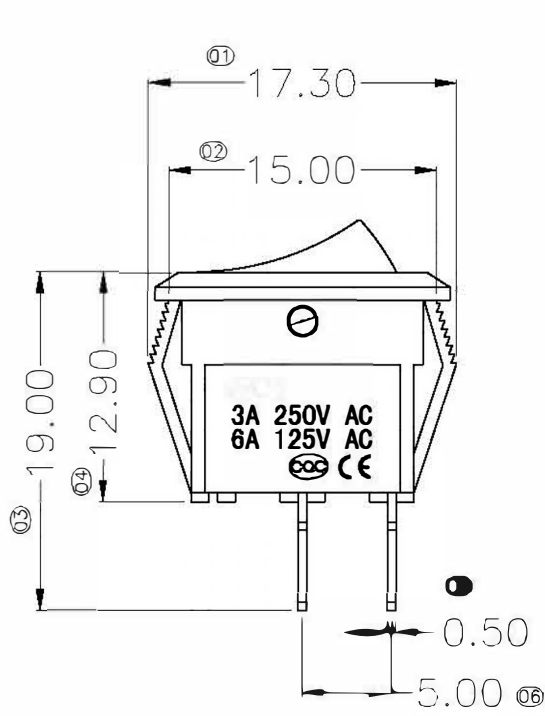

说明:

- 额定值/Rating: CQC, CE:3A 250VAC T85
6A 125VAC T85
- 动作力/Operation force:3~10N;
- 手感: 应顺畅, 换位可靠, 无异常阻滞;
Hand feel: smoothly, release free ,no abnormal
- 接触电阻≤50mΩ
Contact resistance≤50m
- 耐高压:端子与操动件间:1500VAC 5S
端与端:1000VAC 5S;
Dielectric withstand: Terminal to Actuator:1500VAC 5S
Terminal to Terminal:1000VAC 5S
- 绝缘电阻≥100MΩ 500V DC 1min;
Insulation Resistance≥100M 500V DC 1min
- 电气寿命≥1E4
Endurance life≥5E4

未注公差尺寸 Note the tolerance size	一般公差 Tolerance	>0~6	±0.05
		>6~20	±0.1
		>20~50	±0.2
		>50~100	±0.4
		>100	±0.8
	角度尺寸 Angle:		±2°
绘图: Drawing By:			
审核: Check By:			
核准: Approval By:			

名称 name	L-KLS7-046-101021BB	
	料号Material code:	
跷板开关 Rocker switch	单位Unit: mm	比例Scale: 1: 1
	版次Version: A1	视角: ④
第 1 页 共 1 页		
NINGBO KLS ELECTRONIC CO; LTD		