

CAD FILE:

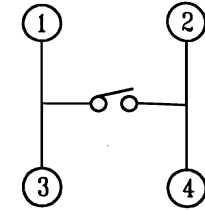

SCHEMATIC

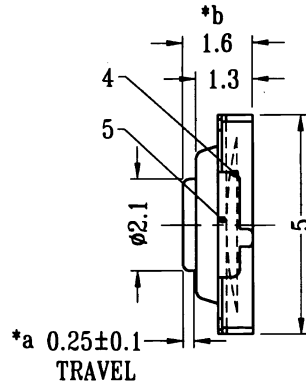
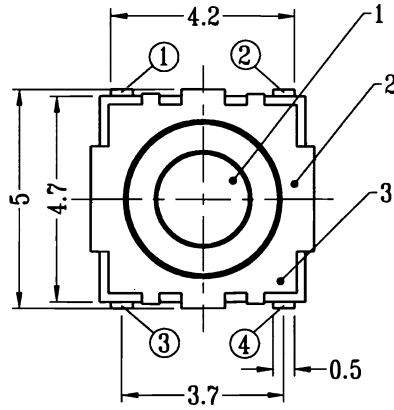
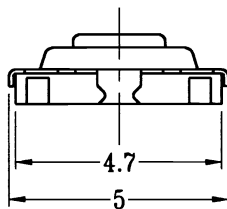

OPERATING FORCE	CODE
160±50gf	X
250±100gf	Z

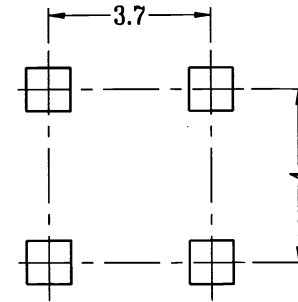

P.C.B LAYOUT

B公司

注：“*”表示關鍵尺寸(2個)

NO.	PARTS	MATERIALS	Q'TY	FINISHINGS	TOLERANCE UNLESS SPECIFIED	ISSUE	DATE	DESCRIPTIONS OF REVISION	APPD.
8					WITHIN 1.5mm : ±0.1mm				
7					OVER 1.5mm : ±0.2mm				
6									
5	SEAL PLATE	PET	1	YELLOW					
4	CONTACT	SUS	1	Ag CLAD					
3	CASE	NYLON+F.G+94V0/BRASS STRIP	1	BLACK/Ag PLATED OVER Ni PLATED					
2	COVER	SUS	1	NATURAL					
1	KNOB	NYLON	1	WHITE					
					TITLE : TACT SWITCH	UNIT : mm		DRWG NO.: SF-DR-TD23XU-00	
					MODEL: TD-23XU	SCALE: 6:1		DWN. 葉滿根	26/Jul/2004
					WEALTH METAL FACTORY LTD.			CHK'D 蔡文傑	26 Jul 2004
								APPD. 黃文傑	26 Jul 2004