

P . C LAYOUT

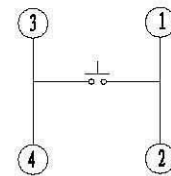
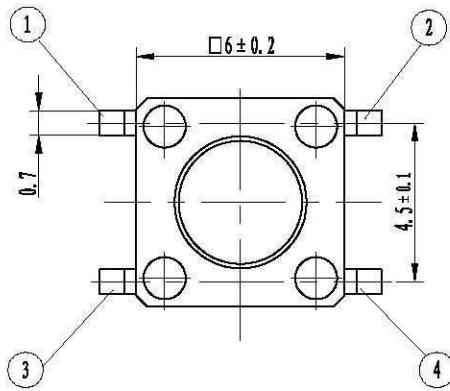

CIRCUIT DIAGRAM

Main Specifications

Climate grade	Rated values	Contact resistance	Dielectric strength	Insulation resistance	Operation force	Life	operating travel
25/070/04	0.05A/30V DC	< 50mΩ	250V. AC	> 100MΩ	260 ± 50gf	50000times	0.25 ± 0.1mm

Tolerances without individual tolerance indications:

0~6	>6~30	>30~120
± 0.2	± 0.3	± 0.4

5	Cover	Fe	1	
4	Handle	PA66	1	Black
3	Reed	F. Ag/Cu	1	
2	Feet	Brass H62	1	
1	Base	Nylon (PA66)	1	Black
No.	Name	Material	Quantity	Note

					KFC-A06-C-1-5					
CHANGE MARK	AMOUNT	LIST NO.	SIGNATURE	DATE	GRADE MARK	WEIGHT	SCALE			
DESIGNER										
CONTROLLER										
PROCESS										
STANDARD					NO. 1		TOTAL 1			
RATIFIER										