

AXP2101 Single Cell NVDC PMU with E-gauge

1. Features

- 3.9V–5.5V Input Operating Range and Support single Cell Battery
- Battery fuel gauge: E gauge 3.0
- Support TWSI(Two Wire Serial Interface) and RSB(Reduced Serial Bus)
- 100mA-1A Linear charger, CV accuracy +/-0.5%
- Single input to support USB input
- High battery discharge efficiency with 50 mOhm
- High integration includes all MOSFETS, current sensing and loop compensation
- Power off current <20uA (BATFET off, RTCLDO output on)
- 4 DCDC
 - DCDC1:1.5~3.4V, I_{MAX}=2A;
 - DCDC2: 0.5~1.2V, 1.22~1.54V, I_{MAX}=2A
 - DCDC3: 0.5~1.2V, 1.22~1.54V, 1.6~3.4V, I_{MAX}=2A
 - DCDC4: 0.5~1.2V, 1.22~1.84V, I_{MAX}=1.5A
 - DCDC5: 1.2V, 1.4~3.7V, I_{MAX}=1A.
- 11 LDOS
 - RTCLDO1~2: 1.8V/2.5V/3V/3.3V, 30mA; Support RTCLDO1 supplied by backup battery (button battery)
 - ALDO1~4: analog LDO,0.5~3.5V, 0.1V/step, I_{MAX}=300mA
 - BLDO1~2: analog LDO,0.5~3.5V, 0.1V/step, I_{MAX}=300mA
 - CPUSLDO: for CPUs, 0.5~1.4V, I_{MAX}=30mA
 - DLDO1~2: analog LDO or power switch, 0.5~3.5V/0.5~1.4V, I_{MAX}=300mA
- startup sequence and default voltage of DCDC/LDO setting
- Protection
 - Input Over-Voltage Protection
 - Battery Thermal Sense Hot/Cold Charge Suspend
 - Programmable Safety Timer for Charger
 - Die Thermal Balance for Charger
 - Thermistor Shutdown

DCDC Over-Voltage/Under-Voltage Protection

2. Applications

- SDV, Car DVR, IPC, smart doorbell, smart speaker

3. Description

AXP2101 is a highly integrated power management IC(PMIC) targeting at single cell Li-battery(Li-ion or Li-polymer) applications that require multi-channel power conversion outputs. It provides an easy and flexible power management solution for multi-core processors to meet the complex and accurate requirements of power control.

AXP2101 supports Linear charge. Besides, it supports 15 channel power outputs which include 5 channel DC-DC and 11 channel LDO. To ensure the security and stability of the system, AXP2101 provides multiple channels 14-bit ADC for voltage/temperature monitor and integrates protection circuits such as over-voltage protection(OVP), over-current protection(OCP) and over-temperature protection(OTP). Moreover, AXP2101 features a unique E-Gauge™ (Fuel Gauge) system, making power gauge easy and exact.

AXP2101 supports TWSI and RSB for system to dynamically adjust output voltages, charge current and configure interrupt condition.

Device Information

Part Number	Package	Body Size
AXP2101	QFN-40	5mm * 5mm

Simplified Application Diagram

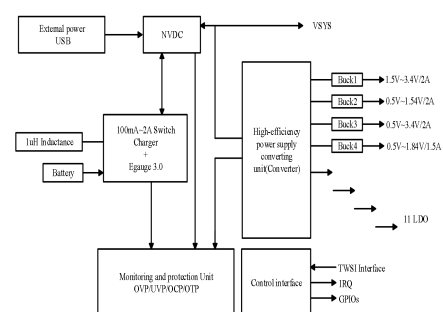

4. Revision History

Revision	Date	Description
V 0.1	April 28,2019	Initial version
V 0.2	Jun 24,2019	Update DCDC5 Description, Register list, Package and Ordering Information



珠海全志科技股份有限公司linfei

珠海全志科技股份有限公司linfei

Contents

1. Features.....	1
2. Applications.....	1
3. Description.....	1
4. Revision History.....	2
5. Pin Configuration and Functions.....	4
6. Specifications.....	6
6.1 Absolute Maximum Ratings ⁽¹⁾	6
6.2 ESD Ratings.....	6
6.3 Recommended Operating Conditions.....	6
6.4 Thermal Information.....	6
7. Detail Description.....	7
7.1 Overview.....	7
7.3 Serial Interface Communication.....	9
7.4 Power Path.....	9
7.5 Power On/Off and reset.....	9
7.5.1 Power on reset(POR).....	9
7.5.2 Power up from BAT.....	9
7.5.3 Power up from VBUS.....	9
7.5.4 System power on/off management.....	10
7.6 Multi-Power Outputs.....	12
7.7 Charger.....	13
7.7.1 Characteristics.....	13
7.7.2 Charging condition.....	13
7.7.3 Charging process.....	13
7.7.4 Charging protection.....	14
7.7.5 Charging indication.....	16
7.8 BATFET.....	17
7.9 RBFET.....	17
7.10 ADC.....	17
7.11 E-Gauge.....	17
7.12 IRQ /BACKUP.....	18
7.12.1 IRQ.....	18
7.12.2 BACKUP.....	18
8. Register.....	18
8.1 Register List.....	18
8.2 Register Description.....	20
10 Package and Ordering Information.....	42
10.1 Package Information.....	42
10.2 Marking information.....	43
10.3 Carrier.....	43
10.4 Storage.....	44
10.5 Baking.....	45
10. Reflow Profile.....	45

5. Pin Configuration and Functions

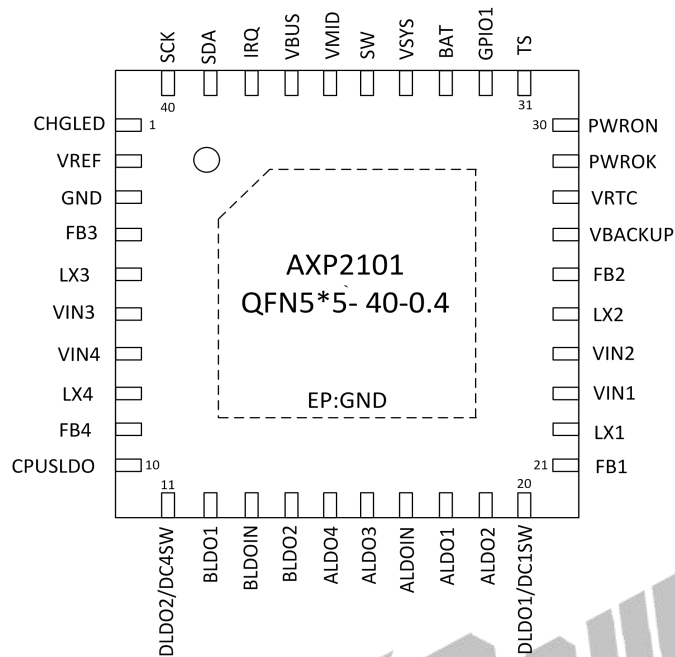

Pin Description

NO.	Pin Name	Type	Description
1	CHGLED	AO	Charge status output to indicate various charger operation.
2	VREF	P	Internal reference voltage
3	GND	AI	Analog ground for interrupt analog and digital circuits.
4	FB3	P	DCDC3 feedback pin
5	LX3	P	Inductor pin for DCDC3
6	VIN3	P	DCDC3 input source
7	VIN4	P	DCDC4 input source
8	LX4	P	Inductor pin for DCDC4
9	FB4	P	DCDC4 feedback pin and Switch input source
10	CPULDOS	P	Output pin of CPULDOS
11	DLDO2/DC4SW	DO	Output pin of DLDO2, and can be configured as the Output pin of DC4SW
12	BLDO1	P	Output pin of BLDO1
13	BLDOIN	P	BLDO input source
14	BLDO2	P	Output pin of BLDO2
15	ALDO4	P	Output pin of ALDO4
16	ALDO3	P	Output pin of ALDO3
17	ALDOIN	P	ALDO input source
18	ALDO1	P	Output pin of ALDO1
19	ALDO2	P	Output pin of ALDO2

20	DLDO1/DC1SW	P	Output pin of DLDO1,and can be configured as the Output pin of DC1SW
21	FB1	P	DCDC1 feedback pin
22	LX1	P	Inductor pin for DCDC1
23	VIN1	P	DCDC1 input source
24	VIN2	P	DCDC2 input source
25	LX2	P	Inductor pin for DCDC2
26	FB2	AI	DCDC2 feedback pin
27	VBackup	P	input pin of backup battery
28	VRTC	P	RTC power output
29	PWROK	DIO	Power good indication output
30	PWRON	DIO	Power On-Off key input, Internal 100k pull up to VINT
31	TS	AI	Temperature qualification voltage input. Connect a negative temperature coefficient thermistor from TS to GND. A current source is injected to TS pin and convert TS voltage to a digital code. Charging suspends when TS pin is out of range. Besides, TS can be connected to external input signal.
32	GPIO1/FB5/RTC LDO2	DIO	Output pin of GPIO1 and can be configured as the Output pin of RTCLDO2 or DCDC5 feedback pin.
33	BAT	P	Battery connection point. The internal BATFET is connected between BAT and SYS. Connect a 1uF capacitor closely to the BAT pin.
34	VSYS	P	System connection point. The internal BATFET is connected between BAT and SYS. Connect two 22uF capacitors closely to the SYS pin.
35	SW	P	Inductor pin for DCDC5
36	VMID	P	VMID Power output
37	VBUS	P	Vbus input
38	IRQ	DIO	Open-drain interrupt Output. Connect the IRQ to a logic rail via a 4.7kΩ resistor. The IRQ pin sends a low level signal to host to report charger device status and fault.
39	SDA	DIO	Data pin for serial interface, needs a 2.2KΩ Pull High.
40	SCK	DI	SCK pin for serial interface, needs a 2.2KΩ Pull High.
EP	EP	GND	Exposed Pad, needs to be connected to system ground

6. Specifications

6.1 Absolute Maximum Ratings ⁽¹⁾

Over operating free-air temperature range (unless otherwise noted)

SYMBOL	DESCRIPTION	MIN	MAX	UNIT
V _{BUS}	Voltage range(with respect to GND)	-0.3	12	V
Others pin (exp vbus,pgnd, gnd)		-0.3	7	V
PGND to GND		-0.3	7	V
PGND to GND		-0.3	0.3	V
T _a	Operating Temperature Range	-40	85	°C
T _j	Junction Temperature Range	-40	125	°C
T _s	Storage Temperature Range	-65	150	°C
T _{LEAD}	Maximum Soldering Temperature (at leads, 10sec)		30	°C

(1) Stresses beyond those listed under absolute maximum ratings may cause permanent damage to the device. These are stress ratings only. Functional operation of the device at these or any other conditions beyond those indicated under recommended operating conditions is not implied. Exposure to absolute maximum rated conditions for extended periods may affect device reliability.

6.2 ESD Ratings

		VALUE	UNIT
V _{ESD}	Human body model(HBM) ⁽¹⁾	±4000	V
	Charged device model(CDM) ⁽²⁾	±750	V

(1) Reference: ESDA/JEDEC JS-001-2014. JEDEC document JEP155 states that 500-V HBM allows safe manufacturing with a standard ESD control process.

(2) Reference: ESDA/JEDEC JS-002-2014. JEDEC document JEP157 states that 250-V CDM allows safe manufacturing with a standard ESD control process.

6.3 Recommended Operating Conditions

SYMBOL	DESCRIPTION	MIN	MAX	UNIT
V _{IN}	Input voltage(VBUS)	3.9	5.5	V
I _{IN}	Input current(VBUS)		2	A
I _{SYS}	Output current		2	A
V _{BAT}	Battery voltage		4.4	V
I _{BAT}	charging current		1	A

6.4 Thermal Information

Thermal Metric ⁽¹⁾		VALUE	UNIT
θ _{JA}	Junction-to-ambient thermal resistance	30	°C/W
θ _{JB}	Junction-to-board thermal resistance	10.8	
θ _{JC}	Junction-to-case(top) thermal resistance	22.8	

(1)Thermal metrics are calculated refer to JEDEC document JESD51.

7. Detail Description

7.1 Overview

AXP2101 is a highly integrated power management IC(PMIC) targeting at single cell Li-battery (Li-ion or Li-polymer) applications that require multi-channel power conversion outputs. It provides an easy and flexible power management solution for multi-core processors to meet the complex and accurate requirements of power control. AXP2101 supports 100mA-1A Linear charge. Besides, it supports 15 channel power outputs which include 5 channel DC-DC and 11 channel LDO. To ensure the security and stability of the system, AXP2101 provides multiple channels 14-bit ADC for voltage/temperature monitor and integrates protection circuits such as over-voltage protection(OVP), over-current protection(OCP) and over-temperature protection(OTP). Moreover, AXP2101 features a unique E-Gauge™ (Fuel Gauge) system, making power gauge easy and exact. AXP2101 supports TWSI and RSB for system to dynamically adjust output voltages, charge current and configure interrupt condition.

AXP2101 is available in 5mm x 5mm 40-pin QFN package.



7.2 Function Block Diagram

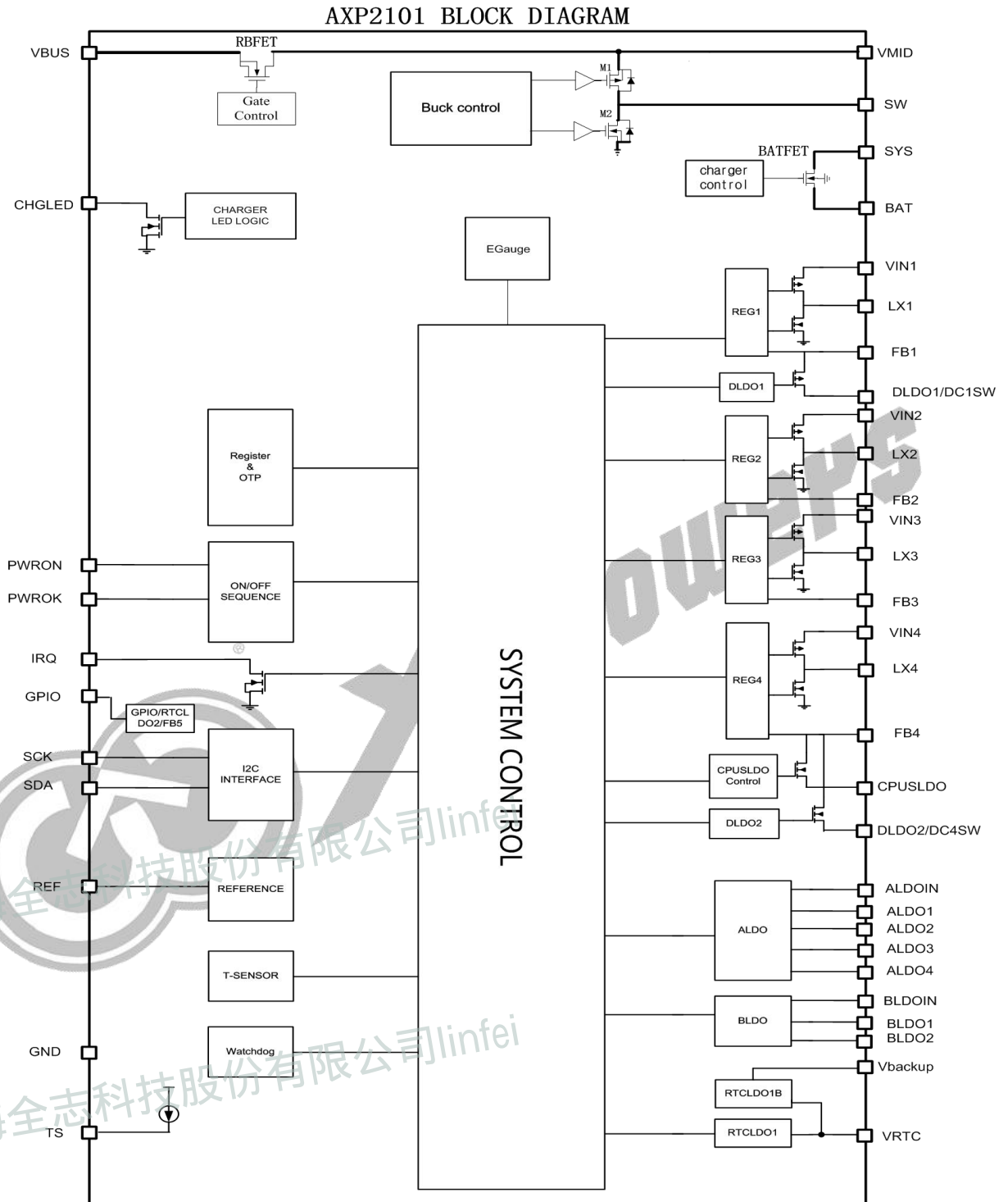

7.3 Serial Interface Communication

AXP2101 supports TWSI protocol and performs as a TWSI slave device with default address 0x68/0x69. When AXP2101 powers on, SCK/SDA pin of TWSI will be pulled up to IO Power and then Host can adjust and monitor AXP2101 with rich feedback information.

Besides, AXP2101 supports RSB for Allwinner platform with address 0x01D1 or 0x0273 by customer.

Note: "Host" here refers to system processor.

7.4 Power Path

VBUS as the charger input, connecting to VSYS pin through a Linear charger, provides power to system and charges battery through BATFET. Charge current can be adjusted automatically according to the feedback current which is detected with an internal resistor. When system current (I_{SYS}) changes, the detected current will change, and then the current change signal will feed back to charge loop to adjust the charge current to the setting value.

When battery voltage is above V_{SYS} , BATFET is turned on and PMU enters supplement mode. When in supplement mode, if the discharge current is lower than 1A, PMU controls the voltage (V_{DS}) between system and battery and keeps V_{DS} at 30mV to avoid entering and exiting supplement mode repeatedly. As discharge current increases, PMU adjusts BATFET to be fully on and V_{DS} increases linearly. If an adapter is not inserted, system current is provided only by battery. At this time, BATFET is at fully on state.

7.5 Power On/Off and reset

7.5.1 Power on reset(POR)

AXP2101 is powered from the higher voltage between VBUS and BAT. When VBUS voltage (V_{VBUS}) is higher than V_{VBUS_UVLOZ} or BAT voltage (V_{BAT}) is higher than V_{BAT_UVLOZ} , the sleep comparator, battery depletion comparator and BATFET driver are be activated. All registers are reset to the default value. TWSI communication is active and Host can communicate with PMU.

7.5.2 Power up from BAT

If only battery is present and V_{BAT} is higher than depletion threshold (V_{BAT_DPLZ}), BATFET, connecting battery to system, is off by default and need to be turned on by pressing the PWRON key or inserting an adapter.

7.5.3 Power up from VBUS

When VBUS is inserted, PMU detects the input voltage to start up the reference voltage and the bias circuit. When V_{VBUS} is higher than V_{VBUS_UVLOZ} , the VBUS insertion IRQ is sent and the register bit reg49H[7] is set to 1 to indicate VBUS is inserted. Then PMU detects the input source whether it is good or not. If Vbus is good, the RBFET is open and V_{SYS} is working.

7.5.3.1 Good source condition

PMU needs to check the current capability of the input source. Only when the input source meets the following

requirements can it start the buck converter.

- a. VBUS voltage is lower than V_{ACOV}
- b. VBUS voltage is higher than $V_{VBUSMIN}$ when pulling I_{BADBUS} (typical 30mA)

Once the input source meets the requirements above,the register bit reg00H[5](VBUS_GD) is set to 1 to indicate the input source is good.

7.5.3.2 Set input voltage limit(V_{INDPM})

AXP2101 supports wide range of input voltage(3.9V~5.5V). V_{INDPM} can be set through reg15H[3:0]. The range of V_{INDPM} is from 3.88V to 5.08V and the step is 80mV.

When VBUS voltage reaches V_{INDPM} , the charge current will decrease automatically until the current is zero. If I_{SYS} is over the input power supply capability, V_{SYS} will drop. If V_{BAT} is above V_{SYS} , PMU will enter the supplement mode.

7.5.4 System power on/off management

PMU has power off and power on status. When at off state, all voltage outputs are turned off except RTCLDO . At this time, the total power consumption is typically 25uA.

7.5.4.1.Power on-off Key (POK)

EN/PWRON pin can be configured as PWRON pin or EN pin by customization. The default is PWRON pin. The Power on-off Key (POK) can be connected between PWRON pin and GND of AXP2101. AXP2101 can automatically identify the four status (Long-press, Short-press, Negative edge, Positive edge) and then correspond respectively.

7.5.4.2.Power on

1.When EN/PWRON pin is configured as PWRON pin, power on sources include:

- (1). POK. AXP2101 can be powered on by pressing and holding POK for a period of time that longer than "ONLEVEL".
- (2). VBUS low go high. The function can be configured by customization.
- (3). VBAT low go high. The function can be configured by customization.
- (4). IRQ Low level. IRQ pin is low level for more than 16ms, AXP2101 will be powered on.The function can be configured by customization.
- (5) . Battery is charged to normal ($V_{bat}>3.3V$ and is charging). The function can be configured by customization.

2.When EN/PWRON pin is used as EN pin, AXP2101 can be powered on by EN pin from low go high(0.6V).

After power on, DC-DC and LDO will be soft booted in preset timing sequence. When IRQ low level power on, AXP2101 can be configured for fast power on by REG2B, and the DCDS/LDOS start sequence can be configured by REG28~REG2B.

7.5.4.3.Power Off

1.When EN/PWRON pin is configured as PWRON pin, power off sources include:

- (1). POK. AXP2101 can be powered off by pressing and holding POK for a period of time that longer than "OFFLEVEL". The function can be configured by REG22H [1] and REG22H [3:2] decides whether the PMU auto turns on or not when it shuts down after OFFLEVEL POK.

- (2). Write "1" to REG10H [0].
- (3). VSYSGOOD high go low. When VSYS<VOFF or VBUS>7V, AXP2101 will be powered off. The default of VOFF is 2.6V which can be configured by REG24H[2:0].
- (4). The output voltage of DCDC is 15% lower than the setting value. The function can be configured by REG23H [4:0].
- (5). The output voltage of DCDC is much larger than their setting. The function can be configured by REG23H [5].
- (6). Die temperature is over the warning level2(145°C). The function can be configured by REG22H [2].

7.5.4.4.Sleep and wakeup

When the running system needs to enter Sleep mode, Maybe one or several power outputs should be disabled or changed to other voltage. Wakeup can be initiated by the following sources:

- 1.Software wakeup (REG26H [1] is set to 1)
- 2.IRQ pin wakeup (REG 26H [4] =1 and IRQ pin is low level for more than 16ms)

These sources will make the all the PMU power outputs resume to the default voltage or the setting voltage, which is configured by REG26H[2], and all shutdown powers will resume by the startup sequence.

See the control process under sleep and wakeup modes as below:

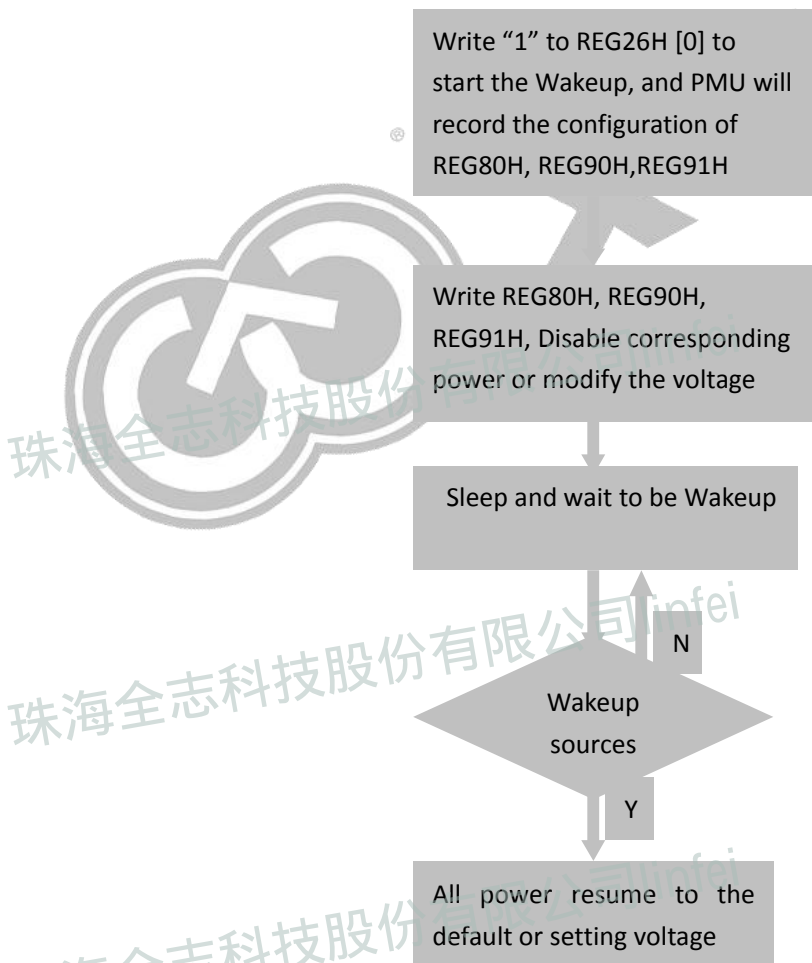

7.5.4.5.Reset

The PMU has system reset and power on reset.

- System reset

System reset means the registers will be reset when PMU is powered on. at system reset state, all voltage outputs are turned off except RTCLDO and VREF. There are three ways of system reset.

(1). PWROK drive low.

The PWROK pin can be used as the reset signal of application system. During AXP2101 startup, PWROK outputs low level, which will be pulled up to startup the system after output voltage reaches the regulated value.

When application system works normally, If the PWROK pin is driven low by external key or other reasons, the PMU will be restarted. The function can be configured by REG10H [3].

(2). Write “1” to REG10H [1] to restart the PMU.

(3). Watchdog timeout. The function can be configured by REG18[0] and REG19[5:4]

- Power on reset

Power on reset means the registers will be reset when PMU is powered up. at power on reset state, all voltage outputs are turned off including RTCLDO and VREF.

7.6 Multi-Power Outputs

The following table has listed the multi-power outputs and their functions of AXP2101.

Output Path	Type	Default Voltage	Startup Sequence	Application Suggestion	Load Capacity(Max)
DCDC1	BUCK	3.3V	3	IO/USB	2000mA
DCDC2	BUCK	0.9V	3	CPU	2000mA
DCDC3	BUCK	0.9V	2	VSYS	2000mA
DCDC4	BUCK	1.1V	1	DDR	1500mA
DCDC5	BUCK	1.2V	OFF	N/A	1000mA
ALDO1	LDO	1.8V	3	N/A	300mA
ALDO2	LDO	2.8V	OFF	N/A	300mA
ALDO3	LDO	3.3V	3	N/A	300mA
ALDO4	LDO	2.9V	OFF	N/A	300mA
BLDO1	LDO	1.8V	OFF	N/A	300mA
BLDO2	LDO	2.8V	OFF	N/A	300mA
DLDO1	LDO	3.3V	OFF	N/A	300mA
DLDO2	LDO	1.2V	OFF	N/A	300mA
VCPUS	LDO	0.9V	1	CPUs/Reference of DDR	30mA
RTC-LDO1	LDO	1.8V	Always on	RTC	30mA
RTC-LDO2	LDO	OFF	OFF	N/A	30mA

AXP2101 includes 5 synchronous step-down DCDCs, 11 LDOs and one switch. The work frequency of DC-DC 1/4 is 3MHz and DCDC2/3/5 is 1.5MHz. External small inductors and capacitors can be connected. In addition, 4-ch DCDCs can be set in fixed PWM mode or auto mode (automatically switchable according to the load). See register REG81H.

DCDC2/3 has DVM enable option. In DVM mode, when there is a change in the output voltage, DCDC will change to the new targeted value step by step. It supports two kinds of DVM slope: 1 step/15.625us and 1step/31.250us. The slope can be chosen by REG80H [5].

AXP2101 can configure the default voltage, the startup sequence and other control of all power output.

Startup sequence : The startup sequence has eight levels from 0 to 7. When the sequence is 0, it means the output is booted at the first step. When the sequence code is 1, it means the output is booted at the second step. When the sequence is 7, it means the output is not booted.

Default voltage setting: The default voltage of each channel can be set to each step within the output range.

7.7 Charger

7.7.1 Characteristics

- Range of input voltage:3.9V~5.5V, PWM charger, supports single cell Li-battery
- Pre-charge current settable ($I_{PRE-CHG}$, reg61 [3:0]), default:125mA, range: 0mA~200mA,step:25mA
- Fast charge current settable (I_{CHG} , reg62[4:0]), default:1024mA, range: 0mA~200mA,step:64mA, 200~1000mA,step:100mA
- Target charge voltage settable (V_{REG} , reg64[2:0]), default:4.2V, range: 4.0v/4.1v/4.2v/4.35v/4.4v/4.6v
- Accuracy of target voltage: $\pm 0.5\%$ (testing ambient temperature:25 $^{\circ}C$,target voltage:4.2V)

7.7.2 Charging condition

- VBUS is present and available, $V_{VBUS} > V_{BAT} + V_{SLEEPZ}$
- Input source detection finishes (reg00H [5] =1)
- Charging is enabled (reg18H [1] =1)
- Die temperature is lower than T_{SHUT}
- When TS pin is used to detect battery temperature, battery temperature is within the chargeable range
- V_{BAT} is lower than V_{BAT_OVP}
- No charger safety timer fault

7.7.3 Charging process

When PMU meets all charging conditions, it can complete the whole charging process without the participation of Host. The charging status can be known from the register bits reg01H[2:0]. The default values of charging parameters are shown as following. Host can modify registers to optimize the values through TWSI.

Table 7-1

Parameter	Default value
Charging voltage	4.208V
Charging current	1.024A

Pre-charging current	125mA
Termination current	125mA
Temperature profile	Cold/hot
Safety timer	12hours

7.7.3.1. Pre-charge

When V_{BAT} is lower than $V_{BATLOWV}(3V)$, the charger is under pre-charge mode where charging current is limited to a value of $I_{PRE-CHG}$. Safety time is set through reg67H [1:0] and its default value is 50 minutes. If pre-charge process times out, PMU will stop charging and send a corresponding IRQ to Host. The function of safety timer can be disabled through reg67H [2].

7.7.3.2. Constant current charge

Once V_{BAT} is higher than $V_{BATLOWV}$ and lower than V_{REG} , the charger is under constant current charge mode. It will charge with constant current I_{CHG} .

7.7.3.3. Constant voltage charge

When V_{BAT} reaches target voltage (V_{REG}), the charger enters constant voltage charge mode. In this stage, the charger keeps the output voltage constant and step down charging current gradually, in order to fully charge battery.

When V_{BAT} is above V_{RECHG} and the charging current reduces under termination current (I_{TERM}), AXP2101 reports charger done, stops charging (charger enable bit is still 1) and turns off BATFET. Meanwhile, IRQ is sent to Host.

When AXP2101 is in regulation of input current, input voltage or temperature, the function of charging termination configured through reg63 [4] is temporarily disabled and the speed of safety timer slows down. Whether to set safety timer during DPM or thermal regulation depends on reg67H [7].

7.7.3.4. Re-charge

After charge done, if V_{BAT} falls below V_{RECHG} , PMU will automatically enable charger without reinserting adapter. No matter whether V_{BAT} is above V_{RECHG} or not, the charger is enabled when an adapter is inserted.

7.7.3.5. Battery detection

As long as an AC adapter is present and usable, battery detection will be enabled to detect whether battery is connected. Battery detection function is enabled by default and can be disabled through reg68H [0]. If the function is disabled, PMU considers that battery is always present. The detection result is saved in reg00H [3]

7.7.4 Charging protection

7.7.4.1. charger safety timer

Once starting pre-charge mode, PMU will enable timer1. If PMU cannot enter constant current charge mode from pre-charge within 50min (set through reg67H [1:0]), PMU will enter battery safe mode and send IRQ to indicate the battery may be damaged.

When the charger enters into constant current charge mode, PMU will enable timer2. If PMU cannot finish the whole charge cycle within 12 hours (set through reg67H [5:4]), PMU will enter battery safe mode and send IRQ to indicate the battery may be damaged.

Timing speed of timer1 or timer2 is relevant with actual charge current. The smaller the actual charge current, the slower timing speed is.

7.7.4.2. Battery safe mode

In battery safe mode, the charger always charges with 10mA current. PMU can quit battery safe mode with one of the following methods:

- $V_{BAT} > V_{RECHG}$
- Adapter removal
- Charger enable bit (reg18H [1]) is reset to 1
- Safety timer1 enable bit or safety timer2 enable bit is reset to 1

7.7.4.3. PMU die temperature protection

AXP2101 has built-in temperature protection function through ADC to monitor internal temperature.

Under charging mode, the temperature point of thermal regulation can be set through reg65H [1:0]. When die temperature rises up to the setting point, the charging current will be decreased to decrease heat. When thermal regulation works, actual charge current is lower than the setting value and thermal regulation status(reg00H [1]) is set to 1. If die temperature rises up to T_{SHUT} (145°C), IRQ is sent, PMU is poweroff. When die temperature falls below hysteretic threshold (120°C), PMU is not poweron automatically.

7.7.4.4. Battery temperature protection

AXP2101 can monitor battery temperature, when TS pin is used to detect battery temperature and parallel with charger(reg50H[4]=0). The battery temperature sensitive resistor is connected between TS pin and GND. The suggestion resistance should be 10Kohm at 25°C ambient temperature. Through TS pin, PMU outputs constant current which can set through reg50H [1:0] to adapt different resistance. When the resistance is 10Kohm, the current should be set to 50uA. The enable bit of TS current source is configured through reg50H [3:2]. When current passes through the temperature sensitive resistor, PMU gets a detected voltage and calculates its value through ADC circuit. Take for example, TH11-3H103F temperature sensitive resistor of Mitsubishi Company. Using 50uA current source, the relationship among temperature, equivalent resistance, detected voltage and ADC data is as following.

Table 7-2

Temperature	equivalent resistance	detected voltage	ADC DATA
-20°C	63.00Kohm	3.150V	189Ch
-15°C	50.15Kohm	2.508V	1398h
-10°C	40.26Kohm	2.013V	FBAh
-5°C	32.55Kohm	1.628V	CB8h
0°C	26.49Kohm	1.325V	A5Ah
5°C	21.68Kohm	1.084V	878h
10°C	17.78Kohm	0.889V	6F2h
15°C	14.63Kohm	0.732V	5B8h
20°C	12.07Kohm	0.604V	4B8h
25°C	10.00Kohm	0.500V	3E8h

30℃	8.320Kohm	0.416V	340h
35℃	6.954Kohm	0.348V	2B8h
40℃	5.839Kohm	0.292V	248h
45℃	4.924Kohm	0.246V	1ECh
50℃	4.171Kohm	0.209V	1A2h
55℃	3.549Kohm	0.177V	162h
60℃	3.032Kohm	0.152V	130h

During battery charging process, if TS pin voltage is lower than VH_{TF-CHG} or higher than VL_{TF-CHG} (VH_{TF-CHG} and VL_{TF-CHG} can be set through reg55H and reg54H. The default value of VL_{TF-CHG} is set around 0℃ and VH_{TF-CHG} around 45℃), which indicates battery temperature is too high or too low, then the charger is paused and IRQ is sent to notify Host. When battery temperature is back to the normal range, the charger will recovery automatically.

During battery discharging mode, if TS pin voltage is lower than VH_{TF-WORK} or higher than VL_{TF-WORK} (VH_{TF-WORK} and VL_{TF-WORK} can be set through reg57H and reg56H. The default value of VL_{TF-WORK} is set around -10℃ and VH_{TF-WORK} around 55℃), which indicates battery temperature is too high or too low, then the boost is paused and IRQ is sent to notify Host. When battery temperature is back to the normal range, the boost will recovery automatically.

High temperature protection threshold hysteresis for VH_{TF-CHG} and VH_{TF-WORK} can be set through reg53H. Low temperature protection threshold hysteresis for VL_{TF-CHG} and VL_{TF-WORK} can be set through reg52H. The range of temperature detection can be expanded by adding more resistors.

Some battery may have no temperature sensitive resistor. Under this situation, TS pin can be pulled down to GND with a 10Kohm resistor externally or set as external input of ADC through register.

7.7.5 Charging indication

CHGLED pin uses open-drain/push-pull output method. It is internally pulled up to LDO. Its output drive capability is above 10mA. Detail function control is shown as the following table.

Table 7-4

REG69H [2:1] = 00 (Type A CHGLED) Open Drain	Hi-Z	No charging(conditions are not met or battery charged)
	25% 1Hz pull low/Hi-Z jump	Charger internal abnormal alarm(including timer out、die temperature over temperature、battery temperature out of charging range)
	25% 4Hz pull low/Hi-Z jump	Input source or battery over voltage
REG69H [2:1] = 01 (Type B CHGLED) Open Drain	Pull low	Charging
	Hi-Z	No VBUS, and power supply by battery
	25% 1Hz pull low/Hi-Z jump	Charging
	25% 4Hz pull low/Hi-Z jump	Alarm, including input source or battery over voltage, battery temperature out of charging range, timer out ,die temperature over temperature

	Pull low	No battery or charge finished, and power supply by VBUS
REG90H[2:0]=10 Cfg chgled	The output status is controlled by REG69H[5:4]	

Note: LED is on when CHGLED is low.

7.8 BATFET

BATFET connects system and battery. The on-resistance is low to 50mohm (point to point).

7.9 RBFET

RBFET connects VMID and VBUS. The on-resistance is low to 100mOhm (point to point). It supports input and output current limit function. In charger mode, the input current limit value of RBFET is set through reg16H [2:0].

7.10 ADC

AXP2101 has a low speed 14 Bits SAR ADC for measuring BAT voltage, Vbus voltage, Vsys voltage, TS voltage and die temperature.

Table 7-5

No.	Channel function	000H	001H	002H	...	FFFH
0	BAT voltage	0mV	1mV	2mV	...	8.192V
1	Vbus voltage	0mV	1mV	2mV	...	8.192V
2	Vsys voltage	0mV	1mV	2mV	...	8.192V
3	TS voltage	0mV	0.5mV	1mV	...	4.096V
4	die temperature	0mV	0.1mV	2mV	...	0.8192V

Note: ADC data is 14 bits. In order to get the complete data, TWSI must read the high 6 bits firstly and then the low 8 bits.

7.11 E-Gauge

The Fuel Gauge comprises of 3 modules: Rdc calculation module; OCV (Open Circuit Voltage) and Coulomb counter module; and calibration module. The Fuel Gauge system is able to export information about battery capacity percentage (regA4H), Battery Voltage (reg34H, reg35H). The Fuel Gauge can be enabled or disabled through reg18H [3]. The Battery low warning level can be set through reg1AH, and IRQ will be sent out to alert the platform when the battery capacity percentage is lower than the warning level set through reg1AH.

Once a default battery is selected for a particular design, it is highly recommended to calibrate the battery to achieve better Fuel Gauge accuracy. Once the calibration data are available, user can write the calibration information to battery parameter (REGA1) on each boot. Additionally, the Fuel Gauge system is capable to learn the battery characteristic on each full charge cycle. Information such as battery maximum capacity and Rdc will be updated automatically over time.

7.12 IRQ /BACKUP

7.12.1 IRQ

AXP2101 has an IRQ pin which is used to indicate whether there interrupt events occur.

PMU Interrupt Controller monitors the trigger events such as over voltage, over current, PWRON pin signal, over temperature and so on. When the events occur and their IRQ enabled bits are set to 1 (Refer to registers reg40H/41H/42H), corresponding IRQ status will be set to 1 (Refer to registers reg48H/49H/4AH), and IRQ pin will be pulled down. When Host detects triggered IRQ signal, Host will scan through the IRQ Status registers and respond accordingly. Meanwhile, Host will reset the IRQ status by writing “1” to status bit.

7.12.2 BACKUP

AXP2101 has a backup pin which is used to connect backup battery. It is the source of RTCLDO1 when pmu has only backup battery.

When PMU is poweron, the backup battery also can be charged by configuring reg18H[2]. The charger is working under linear mode with 100uA charge current and the termination voltage can be configured by reg6AH in range from 2.6V to 3.3V (default 2.9V).

The backup pin can also be configured for the RTCLDO2 by customization.

8. Register

8.1 Register List

Address	Description	R/W
0X00	PMU status1	R
0X01	PMU status2	R
0X04-0X07	DATA BUFFER	RW
0X10	PMU common configure	RW
0X12	BATFET control	RW
0X13	Die temperature control	RW
0X14	Minimum system voltage control	RW
0X15	Input voltage limit control	RW
0X16	Input current limit control	RW
0X17	Reset the fuel gauge	RW
0X18	Charger, fuel gauge , watchdog on/off control	RW
0X19	Watch dog control	RW
0X1A	Low Battery warning threshold setting	RW
0X20	PWRON status	R
0X21	PWROFF status	R
0X22	PWROFF_EN	RW
0X23	PWROFF of DCDC OVP/UVP control	RW

Address	Description	R/W
0X24	Vsys voltage for PWROFF threshold setting	RW
0X25	PWROK setting and PWROFF sequence control	RW
0X26	Sleep and wakeup control	Rw
0X27	IRQLEVEL/OFFLEVEL/ONLEVEL setting	RW
0X28	Fast pwron setting 0	Rw
0X29	Fast pwron setting 1	RW
0X2A	Fast pwron setting 2	RW
0X2B	Fast pwron setting and control	RW
0X30	ADC Channel enable control	RW
0X34-3D	ADC data	RW
0X40-0X42	IRQ Enable	RW
0X48-0X4A	IRQ Status	RW
0X50	TS pin CTRL	RW
0X52	TS_HYSL2H setting	RW
0X53	TS_HYSH2L setting	RW
0X54	VLTF_CHG setting	RW
0X55	VHTF_CHG setting	RW
0X56	VLTF_WORK setting	Rw
0X57	VHTF_WORK setting	Rw
0X58	JIETA standard Enable control	Rw
0x59-0X5B	JIETA standard setting	Rw
0X61	Iprechg charger setting	RW
0X62	ICC charger setting	RW
0X63	Iterm charger setting and control	RW
0X64	CV charger voltage setting	RW
0X65	Thermal regulation threshold setting	RW
0X67	Charger timeout setting and control	RW
0X68	Battery detection control	RW
0X69	CHGLED setting and control	RW
0X6A	Button battery charge termination voltage setting	RW
0X80	DCDCS ON/OFF and DVM control	RW
0X81	DCDCS force PWM control	RW
0X82-0X86	DCDCs voltage setting	RW
0X90-0X91	LDOS ON/OFF control	RW
0X92-0X9A	LDOS voltage setting	RW
0XA1	Battery parameter	RW
0XA2	Fuel gauge control	RW
0XA4	Battery percentage data	R

8.2 Register Description

REG 00: PMU status1

Bit	Description	R/W	Reset	Default
7:6		RO	/	0
5	VBUS good indication 0: not good 1: good	RO	POR	0
4	BATFET state 0: close 1: open	RO	POR	0
3	Battery present state 0: absent 1: present	RO	POR	0
2	Battery in Active Mode 0: in Normal 1: in Active Mode	RO	POR	0
1	Thermal regulation status 0: normal 1: in thermal regulation	RO	POR	0
0	Current Limit state 0: not in current limit state 1: in current limit state	RO	POR	0

REG 01: PMU status2

Bit	Description	R/W	Reset	Default
7		RO	/	0
6:5	Battery Current Direction 00: Standby 01: charge 10: discharg 11: reserved	RO	POR	0
4	System status indication 0: System is power off. 1: System is power on.	RO	POR	0
3	VINDPM status 0: not in VINDPM 1: VINDPM	RO	POR	0
2:0	charging status 000: tri_charge 001: pre_charge 010: constant charge(CC) 011: constant voltage(CV) 100: charge done 101: not charging 11X: reserved	RO	POR	0

REG 04: DATA_BUFFER 0

Bit	Description	R/W	Reset	Default
7:0	data buffer	RW	POR	00h

REG 05: DATA_BUFFER 1

Bit	Description	R/W	Reset	Default
7:0	data buffer	RW	POR	00h

REG 06: DATA_BUFFER 2

Bit	Description	R/W	Reset	Default

7:0	data buffer	RW	POR	00h
-----	-------------	----	-----	-----

REG 07: DATA_BUFFER 3

Bit	Description	R/W	Reset	Default
7:0	data buffer	RW	POR	00h

REG 10: PMU common configuration

Bit	Description	R/W	Reset	Default
7:6		RW	/	0b
5	Internal off-discharge enable for DCDC & LDO & SWITCH 0: disable 1: enable	RW	POR	1b
4		RW	/	1b
3	PWROK PIN pull low to Restart the System 0: disable 1: enable	RW	POR	0b
2	PWRON 16s to shut the PMIC enable 0: disable 1: enable	RW	POR	0b
1	Restart the SoC System, POWOFF/POWON and reset the related registers 0: normal 1: reset	RWAC	POR	0b
0	Soft PWROFF 0: Normal 1: PWROFF	RWAC	POR	0b

REG 12: BATFET control

Bit	Description	R/W	Reset	Default
7:3		RO	/	0
2:1	DIE Over Temperature Protection Level1 Configuration 00: 115deg 01: 125deg 10: 135deg 11: reserved	RW	POR	01b
0	DIE Temperature Detect Enable 0: disable 1: enable	RW	POR	1b

REG 13: Die temperature control

Bit	Description	R/W	Reset	Default
7:3		RO	/	0
2:1	DIE Over Temperature Protection Level1 Configuration 00: 115deg 01: 125deg 10: 135deg 11: reserved	RW	POR	01b
0	DIE Temperature Detect Enable 0: disable 1: enable	RW	POR	1b

REG 14: Minimum system voltage control

Bit	Description	R/W	Reset	Default
7		RO	/	0

6:4	Linear Charger Vsys voltage dpm 4.1+N*0.1 V 000: 4.1V 001: 4.2V 010: 4.3V 011: 4.4V 100: 4.5V 101: 4.6V 110: 4.7V 111: 4.8V	RW	POR	110b
3:0		RO	/	0

REG 15: Input voltage limit control

Bit	Description	R/W	Reset	Default
7:4		RO	/	
3:0	VINDPM configuration: 3.88+N*0.08 V 0000: 3.88V 0001: 3.96V 0010: 4.04V 0011: 4.12V 0100: 4.20V 0101: 4.28V 0110: 4.36V 0111: 4.44V 1000: 4.52V 1001: 4.60V 1010: 4.68V 1011: 4.76V 1100: 4.84V 1101: 4.92V 1110: 5.00V 1111: 5.08V	RW	POR	0110b

REG 16: Input current limit control

Bit	Description	R/W	Reset	Default
7:3		RO	/	
2:0	Input current limit 000: 100mA 001: 500mA 010: 900mA 011: 1000mA 100: 1500mA 101: 2000mA 110-111: reserved	RW	POR	001b

REG 17: Reset the fuel gauge

Bit	Description	R/W	Reset	Default
7:4		RO	/	0
3	reset the gauge 0: normal 1: reset	RWAC	POR	0b
2	reset the gauge besides registers 0: normal 1: reset	RW	POR	0b
1:0		RO	/	0

REG 18: Charger, fuel gauge, watchdog on/off control

Bit	Description	R/W	Reset	Default
7:4		RO	/	0
3	Gauge Module enable 0: disable 1: enable	RW	POR	1b
2	Button Battery charge enable 0: disable 1: enable	RW	System Reset	0b

1	Cell Battery charge enable 0: disable 1: enable	RW	System Reset	1b
0	Watchdog Module enable 0: disable 1: enable	RW	System Reset	0b

REG 19: Watchdog control

Bit	Description	R/W	Reset	Default
7:6		RO	/	0
5:4	Watchdog Reset Configuration 00: IRQ only 01: IRQ and System Reset 10: IRQ, System Reset and Pull down PWROK 1s 11: IRQ, System Reset, DCDC/LDO PWROFF & PWRON	RW	POR	0b
3	watchdog clear signal 0: normal 1: clear	RWAC	POR	0b
2:0	TWSI watchdog timer configuration 000: 1s 001: 2s 010: 4s 011: 8s 100: 16s 101: 32s 110: 64s 111: 128s	RW	POR	110b

REG 1A: Low Battery warning threshold setting

Bit	Description	R/W	Reset	Default
7:4	low battery warning threshold 5-20%, 1% per step 0000: 5% 0001: 6% 1111: 20%	RW	POR	1010b
3:0	low battery shutdown threshold 0-15%, 1% per step 0000: 0% 0001: 1% 1111: 15%	RW	POR	0001b

REG 20: PWRON status

Bit	Description	R/W	Reset	Default
7:6		RO	/	0
5	POWERON always high when EN Mode as POWERON Source 0: no 1: yes	RO	System Reset	0b
4	Battery Insert and Good as POWERON Source 0: no 1: yes	RO	System Reset	0b
3	Battery Voltage > 3.3V when Charged as Source 0: no 1: yes	RO	System Reset	0b
2	Vbus Insert and Good as POWERON Source 0: no 1: yes	RO	System Reset	0b
1	IRQ PIN Pull-down as POWERON Source 0: no 1: yes	RO	System Reset	0b
0	POWERON low for on level when POWERON Mode as POWERON	RO	System	0b

Source	Reset
0: no 1: yes	

REG 21: PWROFF status

Bit	Description	R/W	Reset	Default
7	Die Over Temperature as POWEROFF Source 0: no 1: yes	RO	POR	0b
6	DCDC Over Voltage as POWEROFF Source 0: no 1: yes	RO	POR	0b
5	DCDC Under Voltage as POWEROFF Source 0: no 1: yes	RO	POR	0b
4	VBUS Over Voltage as POWEROFF Source 0: no 1: yes	RO	POR	0b
3	Vsys Under Voltage as POWEROFF Source 0: no 1: yes	RO	POR	0b
2	POWERON always low when EN Mode as POWEROFF Source 0: no 1: yes	RO	POR	0b
1	Software configuration as POWEROFF Source 0: no 1: yes	RO	POR	0b
0	POWERON Pull down for off level when POWERON Mode as POWEROFF Source 0: no 1: yes	RO	POR	0b

REG 22: PWROFF_EN

Bit	Description	R/W	Reset	Default
7:3		RO	/	0
2	DIE Over-Temperature (LEVEL2) as POWEROFF Source enable 0: disable 1: enable	RW	POR	1b
1	PWRON > OFFLEVEL as POWEROFF Source enable 0: disable 1: enable	RW	POR	EFUSE
0	Function Select when btn_pwroff_en=1 and button power-off occur 0: Power-off 1: Restart	RW	POR	EFUSE

REG 23: PWROFF of DCDC OVP/UVp control

Bit	Description	R/W	Reset	Default
7:6		RO	/	0
5	DCDC 120%(130%) high voltage turn off PMIC function 0: disable 1: enable	RW	POR	1b
4	DCDC5 85% low voltage turn off PMIC function 0: disable 1: enable	RW	POR	1b
3	DCDC4 85% low voltage turn off PMIC function 0: disable 1: enable	RW	POR	1b
2	DCDC3 85% low voltage turn off PMIC function	RW	POR	1b

	0: disable 1: enable			
1	DCDC2 85% low voltage turn off PMIC function 0: disable 1: enable	RW	POR	1b
0	DCDC1 85% low voltage turn off PMIC function 0: disable 1: enable	RW	POR	1b

REG 24: Vsys voltage for PWROFF threshold setting

Bit	Description	R/W	Reset	Default
7:3		RO	/	0
2:0	Battery Voltage for POWEROFF 2.6~3.3V, 0.1V/step, 8steps 000: 2.6V 001: 2.7V 111: 3.3V	RW	POR	EFUSE

REG 25: PWROK setting and PWROFF sequence control

Bit	Description	R/W	Reset	Default
7:5		RO	/	0
4	Check the PWROK Pin enable after all dc/dc/lDO output valid 128ms 0: disable 1: enable	RW	POR	1b
3	POWEROFF Delay 4ms after PWROK disable 0: disable 1: enable	RW	POR	1b
2	POWEROFF Sequence Control 0: At the same time 1: the reverse of the Startup	RW	POR	0b
1:0	Delay of PWROK after all power output good 00: 8ms 01: 16ms 10: 32ms 11: 64ms	RW	POR	EFUSE

REG 26: Sleep and wakeup control

Bit	Description	R/W	Reset	Default
7:5		RO	/	0
4	IRQ Pin low to Wakeup 0: disable 1: enable	RW	POR	0b
3	PWROK be low-level enable when Wakeup 0: disable 1: enable	RW	POR	1b
2	DCDC/LDO Voltage Select when Wakeup 0: The Default 1: The voltage before wakeup	RW	POR	0b
1	Wake Up enable 0: disable 1: enable	RWLC	System Reset	0b
0	SLEEP enable 0: disable 1: enable	RWLC	System Reset	0b

REG 27: IRQLEVEL/OFFLEVEL/ONLEVEL setting

Bit	Description	R/W	Reset	Default
-----	-------------	-----	-------	---------

7:6		RO	/	0
5:4	IRQLEVEL configuration 00: 1s 01: 1.5s 10: 2s 11: 2.5s	RW	POR	01b
3:2	OFFLEVEL configuration 00: 4s 01: 6s 10: 8s 11: 10s	RW	POR	01b
1:0	ONLEVEL configuration 00: 128ms 01: 512ms 10: 1s 11: 2s	RW	POR	EFUSE

REG 28: Fast pwrn setting 0

Bit	Description	R/W	Reset	Default
7:6	DCDC4 Fast Power On Start Sequence 00~10: Start Sequence Code 11: disable	RW	POR	0b
5:4	DCDC3 Fast Power On Start Sequence 00~10: Start Sequence Code 11: disable	RW	POR	0b
3:2	DCDC2 Fast Power On Start Sequence 00~10: Start Sequence Code 11: disable	RW	POR	0b
1:0	DCDC1 Fast Power On Start Sequence 00~10: Start Sequence Code 11: disable	RW	POR	0b

REG 29: Fast pwrn setting 1

Bit	Description	R/W	Reset	Default
7:6	ALD03 Fast Power On Start Sequence 00~10: Start Sequence Code 11: disable	RW	POR	0b
5:4	ALD02 Fast Power On Start Sequence 00~10: Start Sequence Code 11: disable	RW	POR	0b
3:2	ALD01 Fast Power On Start Sequence 00~10: Start Sequence Code 11: disable	RW	POR	0b
1:0	DCDC5 Fast Power On Start Sequence 00~10: Start Sequence Code 11: disable	RW	POR	0b

REG 2A: Fast pwrn setting 2

Bit	Description	R/W	Reset	Default
7:6	CPUSLD0 Fast Power On Start Sequence 00~10: Start Sequence Code 11: disable	RW	POR	0b
5:4	BLD02 Fast Power On Start Sequence 00~10: Start Sequence Code 11: disable	RW	POR	0b
3:2	BLD01 Fast Power On Start Sequence 00~10: Start Sequence Code 11: disable	RW	POR	0b
1:0	ALD04 Fast Power On Start Sequence 00~10: Start Sequence Code 11: disable	RW	POR	0b

REG 2B: Fast pwron setting 3

Bit	Description	R/W	Reset	Default
7	Fast Power On Enable 0: disable 1: enable	RW	POR	0b
6	Fast Wake up Enable 0: disable 1: enable	RW	POR	0b
5:4		RO	/	0b
3:2	DLD02 Fast Power On Start Sequence 00~10: Start Sequence Code 11: disable	RW	POR	0b
1:0	DLD01 Fast Power On Start Sequence 00~10: Start Sequence Code 11: disable	RW	POR	0b

REG 30: ADC Channel enable control 0

Bit	Description	R/W	Reset	Default
7:6		RO	/	0
5	general purpose ADC channel enable 0: disable 1: enable	RW	POR	0b
4	die temperature measure ADC channel enable 0: disable 1: enable	RW	POR	0b
3	system voltage voltage measure ADC channel enable 0: disable 1: enable	RW	POR	0b
2	vbus voltage measure ADC channel enable 0: disable 1: enable	RW	POR	0b
1	TS pin measure ADC channel enable 0: disable 1: enable	RW	POR	1b
0	battery voltage measure ADC channel enable 0: disable 1: enable	RW	POR	1b

REG 34: vbat_h

Bit	Description	R/W	Reset	Default
7:6	ch_dbg_en_1 is ch_dbg_en[1:0] ch_dbg_en: 000: disable 001: vbat use all channels 010: ts use all channels 011: vbus use all channels 100: vsys use all channels 101: tdie use all channels 110: gpadc use all channels 111: reserved	RW	POR	0b
5:0	vbat[13:8]	RO	POR	0b

REG 35: vbat_l

Bit	Description	R/W	Reset	Default
7:0	vbat[7:0]	RO	POR	0b

REG 36: ts_h

Bit	Description	R/W	Reset	Default
-----	-------------	-----	-------	---------

7	ADC in low frequency sample mode when PWROFF and Battery only enable(64s) 0: disable 1: enable	RW	POR	1b
6	ch_dbg_en_h is ch_dbg_en[2]	RW	POR	0b
5:0	ts[13:8]	RO	POR	0b

REG 37: ts_1

Bit	Description	R/W	Reset	Default
7:0	ts[7:0]	RO	POR	0b

REG 38: vbus_h

Bit	Description	R/W	Reset	Default
7:6		RO	/	0
5:0	vbus[13:8]	RO	POR	0b

REG 39: vbus_1

Bit	Description	R/W	Reset	Default
7:0	vbus[7:0]	RO	POR	0b

REG 3A: vsys_h

Bit	Description	R/W	Reset	Default
7:6		RO	/	0
5:0	vsys[13:8]	RO	POR	0b

REG 3B: vsys_1

Bit	Description	R/W	Reset	Default
7:0	vsys[7:0]	RO	POR	0b

REG 3C: tdie_h

Bit	Description	R/W	Reset	Default
7:6		RO	/	0
5:0	tdie[13:8]	RO	POR	0b

REG 3D: tdie_l

Bit	Description	R/W	Reset	Default
7:0	tdie[7:0]	RO	POR	0b

REG 40: IRQ Enable 0

Bit	Description	R/W	Reset	Default
7	SOC drop to Warning Level2 IRQ(socwl2_irq) enable 0: disable 1: enable	RW	System Reset	1b
6	SOC drop to Warning Level1 IRQ(socwl1_irq) enable	RW	System	1b

	0: disable 1: enable		Reset	
5	Gauge Watchdog Timeout IRQ(gwdt_irq) enable 0: disable 1: enable	RW	System Reset	1b
4	Gauge New SOC IRQ(lowsoc_irq) enable 0: disable 1: enable	RW	System Reset	1b
3	Battery Over Temperature in Charge mode IRQ(bcot_irq) enable 0: disable 1: enable	RW	System Reset	1b
2	Battery Under Temperature in Charge mode IRQ(bcut_irq) enable 0: disable 1: enable	RW	System Reset	1b
1	Battery Over Temperature in Work mode IRQ(bwot_irq) enable 0: disable 1: enable	RW	System Reset	1b
0	Battery Under Temperature in Work mode IRQ(bwut_irq) enable 0: disable 1: enable	RW	System Reset	1b

REG 41: IRQ Enable 1

Bit	Description	R/W	Reset	Default
7	VBUS Insert IRQ(vinsert_irq) enable 0: disable 1: enable	RW	System Reset	1b
6	VBUS Remove IRQ(vremove_irq) enable 0: disable 1: enable	RW	System Reset	1b
5	Battery Insert IRQ(binsert_irq) enable 0: disable 1: enable	RW	System Reset	1b
4	Battery Remove IRQ(bremove_irq) enable 0: disable 1: enable	RW	System Reset	1b
3	POWERON Short PRESS IRQ(ponsp_irq_en) enable 0: disable 1: enable	RW	System Reset	1b
2	POWERON Long PRESS IRQ(ponlp_irq) enable 0: disable 1: enable	RW	System Reset	1b
1	POWERON Negative Edge IRQ(ponne_irq_en) enable 0: disable 1: enable	RW	System Reset	0b
0	POWERON Positive Edge IRQ(ponpe_irq_en) enable 0: disable 1: enable	RW	System Reset	0b

REG 42: IRQ Enable 2

Bit	Description	R/W	Reset	Default
7	Watchdog Expire IRQ(wdexp_irq) enable 0: disable 1: enable	RW	System Reset	0b
6	LDO Over Current IRQ(ldooc_irq) enable 0: disable 1: enable	RW	System Reset	1b
5	BATFET Over Current Protection IRQ(bcpc_irq) enable	RW	System	0b

	0: disable 1: enable		Reset	
4	Battery charge done IRQ(chgdn_irq) enable 0: disable 1: enable	RW	System Reset	1b
3	Charger start IRQ(chgst_irq) enable 0: disable 1: enable	RW	System Reset	1b
2	DIE Over Temperature level1 IRQ(dotl1_irq) enable 0: disable 1: enable	RW	System Reset	1b
1	Charger Safety Timer1/2 expire IRQ(chgte_irq) enable 0: disable 1: enable	RW	System Reset	1b
0	Battery Over Voltage Protection IRQ(bovp_irq) enable 0: disable 1: enable	RW	System Reset	1b

REG 48: IRQ Status 0

Bit	Description	R/W	Reset	Default
7	SOC drop to Warning Level IRQ 0: no irq 1: irq when SOC >= Warning Level or SOC < shutdown Level to clear it	RW1C	POR	0b
6	SOC drop to Shutdown Level IRQ 0: no irq 1: irq when SOC >= Shutdown Level to clear it	RW1C	POR	0b
5	Gauge Watchdog Timeout IRQ 0: no irq 1: irq	RW1C	POR	0b
4	Gauge New SOC IRQ 0: no irq 1: irq	RW1C	POR	0b
3	Battery Over Temperature in Charge mode IRQ 0: no irq 1: irq Battery Temperature to normal to clear it	RW1C	POR	0b
2	Battery Under Temperature in Charge mode IRQ 0: no irq 1: irq Battery Temperature to normal to clear it	RW1C	POR	0b
1	Battery Over Temperature in Work mode IRQ 0: no irq 1: irq Battery Temperature to normal to clear it	RW1C	System Reset	0b
0	Battery Under Temperature in Work mode IRQ 0: no irq 1: irq Battery Temperature to normal to clear it	RW1C	System Reset	0b

REG 49: IRQ Status 1

Bit	Description	R/W	Reset	Default
7	VBUS Insert IRQ 0: no irq 1: irq VBUS Remove to clear it	RW1C	POR	0b
6	VBUS Remove IRQ	RW1C	POR	0b

	0: no irq 1: irq VBUS Insert to clear it			
5	Battery Insert IRQ 0: no irq 1: irq Battery Remove to clear it	RW1C	POR	0b
4	Battery Remove IRQ 0: no irq 1: irq Battery Insert to clear it	RW1C	POR	0b
3	POWERON Short PRESS IRQ 0: no irq 1: irq	RW1C	System Reset	0b
2	POWERON Long PRESS IRQ 0: no irq 1: irq	RW1C	System Reset	0b
1	POWERON Negative Edge IRQ 0: no irq 1: irq	RW1C	System Reset	0b
0	POWERON Positive Edge IRQ 0: no irq 1: irq	RW1C	System Reset	0b

REG 4A: IRQ Status 2

Bit	Description	R/W	Reset	Default
7	Watchdog Expire IRQ 0: no irq 1: irq	RW1C	POR	0b
6	LDO Over Current IRQ 0: no irq 1: irq LDO Current to normal to clear it	RW1C	System Reset	0b
5	BATFET Over Current Protection IRQ 0: no irq 1: irq	RW1C	POR	0b
4	Battery charge done IRQ 0: no irq 1: irq Battery charge start to clear it	RW1C	POR	0b
3	Battery charge start IRQ 0: no irq 1: irq Battery charge done to clear it	RW1C	POR	0b
2	DIE Over Temperature level1 IRQ 0: no irq 1: irq DIE Temperature to normal to clear it	RW1C	POR	0b
1	Charger Safety Timer1/2 expire IRQ 0: no irq 1: irq	RW1C	POR	0b
0	Battery Over Voltage Protection IRQ 0: no irq 1: irq Battery Voltage to normal to clear it	RW1C	POR	0b

REG 50: TS pin CTRL

Bit	Description	R/W	Reset	Default
7:5		RO	/	0

4	TS PIN function select: 0: TS pin is the battery temperature sensor input and will affect the charger 1: TS pin is the external fixed input and doesn't affect the charger	RW	POR	EFUSE
3:2	TS current source on/off enable 00: off 01: on when TS channel of ADC is enabled 10: on only when TS channel is working and off when others channel is working 11: always on	RW	POR	EFUSE
1:0	current source to TS pin configuration 00: 20uA 01: 40uA 10: 50uA 11: 60uA	RW	POR	10b

REG 52: TS_HYSL2H setting

Bit	Description	R/W	Reset	Default
7:0	hysteresis for TS from low go to normal Thys = N*16mV (default 32mV)	RW	POR	2h

REG 53: TS_HYSH2L setting

Bit	Description	R/W	Reset	Default
7:0	hysteresis for TS from high go to normal Thys = N*4mV (default 4mV)	RW	POR	1h

REG 54: VLTFCHG setting

Bit	Description	R/W	Reset	Default
7:0	VLTF in voltage of charge configuration VLTF = N*32 mV (default is about 0deg) This is also T1 of JEITA	RW	POR	29h

REG 55: VHTFCHG setting

Bit	Description	R/W	Reset	Default
7:0	VHTF in voltage of charge configuration VHTF = N*2 mV (default is about 55deg) This is also T4 of JEITA	RW	POR	58h

REG 56: VLTFWORK setting

Bit	Description	R/W	Reset	Default
7:0	VLTF in voltage of work configuration VLTF = N*32 mV (default is about -10deg)	RW	POR	3Eh

REG 57: VHTFWORK setting

Bit	Description	R/W	Reset	Default

7:0	VHTF in voltage of work configuration VHTF = N*2 mV (default is about 60deg)	RW	POR	4Ch
-----	---	----	-----	-----

REG 58: JEITA standard Enable control

Bit	Description	R/W	Reset	Default
7:1		RO	/	0
0	JEITA Standard Enable 0: disable 1: enable	RW	POR	EFUSE

REG 59: JEITA CV configuration

Bit	Description	R/W	Reset	Default
7		RO	/	0
6	Current fall of Warm in JEITA Standard 0: 100% 1: 50%	RW	POR	0b
5		RO	/	0
4	Current fall of Cool in JEITA Standard 0: 100% 1: 50%	RW	POR	1b
3:2	Voltage fall of Warm in JEITA Standard 00: 0mV 01: 4.1/4.2/4.35/4.4V 的 1 档位 10: 4.1/4.2/4.35/4.4V 的 2 档位 11: reserved	RW	POR	01b
1:0	Voltage fall of Cool in JEITA Standard 00: 0mV 01: 4.1/4.2/4.35/4.4V 的 1 档位 10: 4.1/4.2/4.35/4.4V 的 2 档位 11: reserved	RW	POR	00b

REG 5A: JEITA Cool configuration

Bit	Description	R/W	Reset	Default
7:0	Cool Temperature(T2) in voltage of charge configuration VHTF = N*16 mV (default is about 10deg)	RW	POR	37h

REG 5B: JEITA Warm configuration

Bit	Description	R/W	Reset	Default
7:0	Warm Temperature(T3) in voltage of charge configuration VHTF = N*8 mV (default is about 45deg)	RW	POR	1Eh

REG 5C: ts_cfg_data_h

Bit	Description	R/W	Reset	Default
7:6		RO	/	0
5:0	ts_cfg_data[13:8]	RW	POR	2h

REG 5D: ts_cfg_data_l

Bit	Description	R/W	Reset	Default
7:0	ts_cfg_data[7:0], ts_cfg_data is TS Voltage configured by MCU when ts_ch_en = 0b	RO	POR	58h

REG 61: Iprechg charger setting

Bit	Description	R/W	Reset	Default
7:4		RO	/	0
3:0	Precharge current limit: 25*N mA 0000: 0mA 0001: 25mA 0010: 50mA 0011: 75mA 0100: 100mA 0101: 125mA 0110: 150mA 0111: 175mA 1000: 200mA 1001~1111: reserved	RW	POR	0101b

REG 62: ICC charger setting

Bit	Description	R/W	Reset	Default
7:5		RO	/	0
4:0	constant current charge current limit: 25*N mA if N<=8 200+100*(N-8) mA if N>8 00000: 0mA 00100: 100mA 00101: 125mA 00110: 150mA 00111: 175mA 01000: 200mA 01001: 300mA 01010: 400mA 01011: 500mA 01100: 600mA 01101: 700mA 01110: 800mA 01111: 900mA 10000: 1000mA others: reserved	RW	POR	{EFUSE, 0b, EFUSE}

REG 63: Iterm charger setting and control

Bit	Description	R/W	Reset	Default
7:5		RO	/	0b
4	Charging termination of current enable 0: disable 1: enable	RW	System Reset	1b
3:0	Termination current limit: 25*N mA 0000: 0mA 0001: 25mA 0010: 50mA 0011: 75mA 0100: 100mA 0101: 125mA 0110: 150mA 0111: 175mA 1000: 200mA 1001~1111: reserved	RW	POR	0101b

REG 64: CV charger voltage setting

Bit	Description	R/W	Reset	Default
7:3		RO	/	0
2:0	Charge voltage limit 000: 4.6V 001: 4.0V 010: 4.1V 011: 4.2V 100: 4.35V 101: 4.4V 11X: reserved	RW	POR	011b

REG 65: Thermal regulation threshold setting

Bit	Description	R/W	Reset	Default
7:2		RO	/	0
1:0	Thermal regulation threshold 00: 60deg 01: 80deg 10: 100deg 11: 120deg	RW	System Reset	10b

REG 67: Charger timeout setting and control

Bit	Description	R/W	Reset	Default
7	safety timer1/2 setting during DPM or thermal regulation 0: safety timer not slowed during input DPM or thermal regulation 1: safety timer slowed during input DPM or thermal regulation	RW	POR	1b
6	charge done safe timer enable 0: disable 1: enable	RW	POR	1b
5:4	charge done safety timer configuration 00: 5hours 01: 8hours 10: 12hours 11: 20hours	RW	POR	10b
3		RO	/	0
2	pre-charge safe timer enable 0: disable 1: enable	RW	POR	1b
1:0	pre-charge safe timer configuration 00: 40mins 01: 50mins 10: 60mins 11: 70mins	RW	POR	10b

REG 68: Battery detection control

Bit	Description	R/W	Reset	Default
7:1		RO	/	0
0	battery detection enable 0: disable 1: enable	RW	POR	1b

REG 69: CHGLED setting and control

Bit	Description	R/W	Reset	Default
7:6		RO	/	0
5:4	CHGLED pin output when the register of chgled_func is set to 10b 00: Hiz; 01: Low/Hiz 25%/75% duty 1Hz; 10: Low/Hiz 25%/75% duty 4Hz; 11: drive low;	RW	System Reset	00b
3		RO	/	0
2:1	CHGLED pin display function configuration 00: display with type A function 01: display with type B function 10: output controlled by the register of chgled_out_ctrl	RW	POR	EFUSE

	11: reserved			
0	CHGLED pin enable 0: disable CHGLED pin function 1: enable CHGLED pin function	RW	POR	1b

REG 6A: Button battery charge termination voltage setting

Bit	Description	R/W	Reset	Default
7:3		RO	/	0
2:0	Button Battery charge termination voltage 2.6~3.3V, 100mV/step, 8steps 000: 2.6V 001: 2.7V 010: 2.8V 011: 2.9V 100: 3.0V 101: 3.1V 110: 3.2V 111: 3.3V	RW	POR	011b

REG 80: DCDCS ON/OFF and DVM control

Bit	Description	R/W	Reset	Default
7		RO	/	0b
6	force DCDC work in CCM mode 0: disable 1: enable	RW	System Reset	0b
5	DVM voltage ramp control 0: 15.625 us/step 1: 31.250 us/step	RW	System Reset	0b
4	DCDC5 enable 0: disable 1: enable	RW	System Reset	EFUSE
3	DCDC4 enable 0: disable 1: enable	RW	System Reset	EFUSE
2	DCDC3 enable 0: disable 1: enable	RW	System Reset	EFUSE
1	DCDC2 enable 0: disable 1: enable	RW	System Reset	EFUSE
0	DCDC1 enable 0: disable 1: enable	RW	System Reset	EFUSE

REG 81: DCDCS force PWM control

Bit	Description	R/W	Reset	Default
7	DCDC frequency spread enable 0: disable 1: enable	RW	System Reset	0b
6	DCDC frequency spread range control 0: 50KHz 1: 100kHz	RW	System Reset	0b
5	DCDC4 PWM/PFM Control 0: Auto Switch 1: Always PWM	RW	System Reset	0b
4	DCDC3 PWM/PFM Control 0: Auto Switch 1: Always PWM	RW	System Reset	0b
3	DCDC2 PWM/PFM Control 0: Auto Switch 1: Always PWM	RW	System Reset	0b

2	DCDC1 PWM/PFM Control 0: Auto Switch 1: Always PWM	RW	System Reset	0b
1:0	DCDC UVP debounce time configuration 00: 60us 01: 120us 10: 180us 11: 240us	RW	POR	00b

REG 82: DCDC1 voltage setting

Bit	Description	R/W	Reset	Default
7:5		RO	/	0
4:0	DCDC1 output voltage configuration 1.5~3.4V, 100mV/step, 20steps 00000: 1.5V 00001: 1.6V 10011: 3.4V 10100~11111: reserved	RW	System Reset	EFUSE

REG 83: DCDC2 voltage setting

Bit	Description	R/W	Reset	Default
7	DCDC2 DVM enable control 0: disable 1: enable	RW	System Reset	0b
6:0	DCDC2 output voltage configuration 0.5~1.2V, 10mV/step, 71steps 1.22~1.54V, 20mV/step, 17steps 0000000: 0.50V 0000001: 0.51V 1000110: 1.20V 1000111: 1.22V 1001000: 1.24V 1010111: 1.54V 1011000~1111111: reserved	RW	System Reset	EFUSE

REG 84: DCDC3 voltage setting

Bit	Description	R/W	Reset	Default
7	DCDC3 DVM enable control 0: disable 1: enable	RW	System Reset	0b
6:0	DCDC3 output voltage configuration 0.5~1.2V, 10mV/step, 71steps 1.22~1.54V, 20mV/step, 17steps 1.6~3.4V, 100mV/step, 19steps 0000000: 0.50V 0000001: 0.51V 1000110: 1.20V 1000111: 1.22V	RW	System Reset	EFUSE

1001000: 1.24V			
.....			
1010111: 1.54V			
1011000: 1.60V			
1011001: 1.70V			
.....			
1101011: 3.40V	1101100~1111111: reserved		

REG 85: DCDC4 voltage setting

Bit	Description	R/W	Reset	Default
7		RO	/	0
6:0	DCDC4 output voltage configuration 0.5~1.2V, 10mV/step, 71steps 1.22~1.84V, 20mV/step, 32steps 0000000: 0.50V 0000001: 0.51V 1000110: 1.20V 1000111: 1.22V 1001000: 1.24V 1100110: 1.84V 1100111~1101000: reserved	RW	System Reset	EFUSE

REG 86: DCDC5 voltage setting

Bit	Description	R/W	Reset	Default
7:6		RO	/	0
5	slow down dc5 frequency compensation enable 0: disable 1: enable	RW	System Reset	0b
4:0	DCDC5 output voltage configuration 1.4~3.7V, 100mV/step, 24steps 11001: 1.2V 00000: 1.4V 00001: 1.5V 10111: 3.7V 11000~11111: reserved	RW	System Reset	EFUSE

REG 90: LDOS ON/OFF control 0

Bit	Description	R/W	Reset	Default
7	dldo1 enable 0: disable 1: enable	RW	System Reset	EFUSE
6	cpusldo enable 0: disable 1: enable	RW	System Reset	EFUSE
5	bldo2 enable	RW	System	EFUSE

	0: disable 1: enable		Reset	
4	aldo1 enable 0: disable 1: enable	RW	System Reset	EFUSE
3	aldo4 enable 0: disable 1: enable	RW	System Reset	EFUSE
2	aldo3 enable 0: disable 1: enable	RW	System Reset	EFUSE
1	aldo2 enable 0: disable 1: enable	RW	System Reset	EFUSE
0	aldo1 enable 0: disable 1: enable	RW	System Reset	EFUSE

REG 91: LDOS ON/OFF control 1

Bit	Description	R/W	Reset	Default
7:1		RO	/	0
0	dldo2 enable 0: disable 1: enable	RW	System Reset	EFUSE

REG 92: ALDO1 voltage setting

Bit	Description	R/W	Reset	Default
7:5		RO	/	0
4:0	aldo1 output voltage configuration 0.5~3.5V, 100mV/step, 31steps 00000: 0.5V 00001: 0.6V 11110: 3.5V 11111: reserved	RW	System Reset	EFUSE

REG 93: ALDO2 voltage setting

Bit	Description	R/W	Reset	Default
7:5		RO	/	0
4:0	aldo2 output voltage configuration 0.5~3.5V, 100mV/step, 31steps 00000: 0.5V 00001: 0.6V 11110: 3.5V 11111: reserved	RW	System Reset	EFUSE

REG 94: ALDO3 voltage setting

Bit	Description	R/W	Reset	Default
7:5		RO	/	0
4:0	aldo3 output voltage configuration 0.5~3.5V, 100mV/step, 31steps 00000: 0.5V	RW	System Reset	EFUSE

00001: 0.6V 11110: 3.5V	11111: reserved			
-------------------------------------	-----------------	--	--	--

REG 95: ALDO4 voltage setting

Bit	Description	R/W	Reset	Default
7:5		RO	/	0
4:0	aldo4 output voltage configuration 0.5~3.5V, 100mV/step, 31steps 00000: 0.5V 00001: 0.6V 11110: 3.5V	RW	System Reset	EFUSE
	11111: reserved			

REG 96: BLDO1 voltage setting

Bit	Description	R/W	Reset	Default
7:5		RO	/	0
4:0	bldo1 output voltage configuration 0.5~3.5V, 100mV/step, 31steps 00000: 0.5V 00001: 0.6V 11110: 3.5V	RW	System Reset	EFUSE
	11111: reserved			

REG 97: BLDO2 voltage setting

Bit	Description	R/W	Reset	Default
7:5		RO	/	0
4:0	bldo2 output voltage configuration 0.5~3.5V, 100mV/step, 31steps 00000: 0.5V 00001: 0.6V 11110: 3.5V	RW	System Reset	EFUSE
	11111: reserved			

REG 98: CPUSLDO voltage setting

Bit	Description	R/W	Reset	Default
7:5		RO	/	0
4:0	cpusldo output voltage configuration 0.5~1.4V, 50mV/step, 20steps 00000: 0.50V 00001: 0.55V 10011: 1.40V	RW	System Reset	EFUSE
	10100~11111: reserved			

REG 99: DLDO1 voltage setting

Bit	Description	R/W	Reset	Default
7:5		RO	/	0
4:0	dldo1 output voltage configuration 0.5~3.5V, 100mV/step, 31steps 00000: 0.5V 00001: 0.6V 11110: 3.5V 11111: reserved	RW	System Reset	EFUSE

REG 9A: DLDO2 voltage setting

Bit	Description	R/W	Reset	Default
7:5		RO	/	0
4:0	dldo2 output voltage configuration 0.5~1.4V, 50mV/step, 20steps 00000: 0.50V 00001: 0.55V 10011: 1.40V 10100~11111: reserved	RW	System Reset	EFUSE

REG A1: Battery parameter

Bit	Description	R/W	Reset	Default
7:0	Battery parameter ROM	RO	POR	xx

REG A2: Fuel gauge control

Bit	Description	R/W	Reset	Default
7:6	reserved	RO	/	0b
5	reserved	RW	POR	0b
4	ROM or SRAM select 1: select sram; 0: select rom;	RW	POR	0b
3:1	reserved	RO	/	0b
0	brom writer control 1:enable 0:disable	RW	POR	0b

REG A4: Battery percentage data

Bit	Description	R/W	Reset	Default
7:0	battery percentage	RO	POR	00h

9. Application Information

9.1 Typical Application

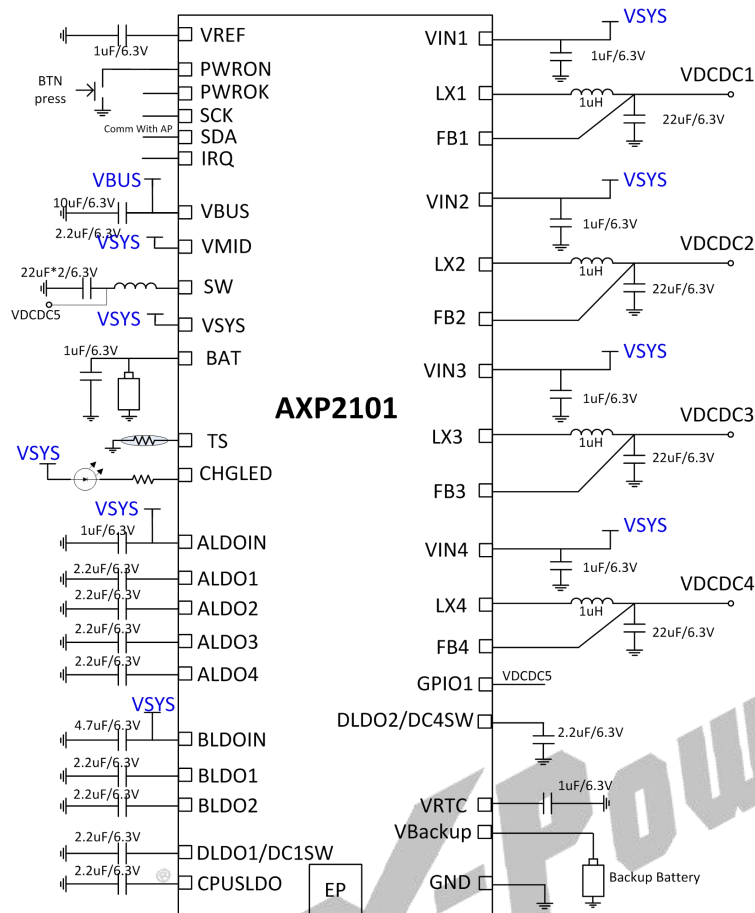

珠海全志科技股份有限公司infei

珠海全志科技股份有限公司infei

10.Package and Ordering Information

10.1 Package Information

AXP2101 package is QFN5*5, 40-pin. Figure 10-1 shows AXP2101 package.

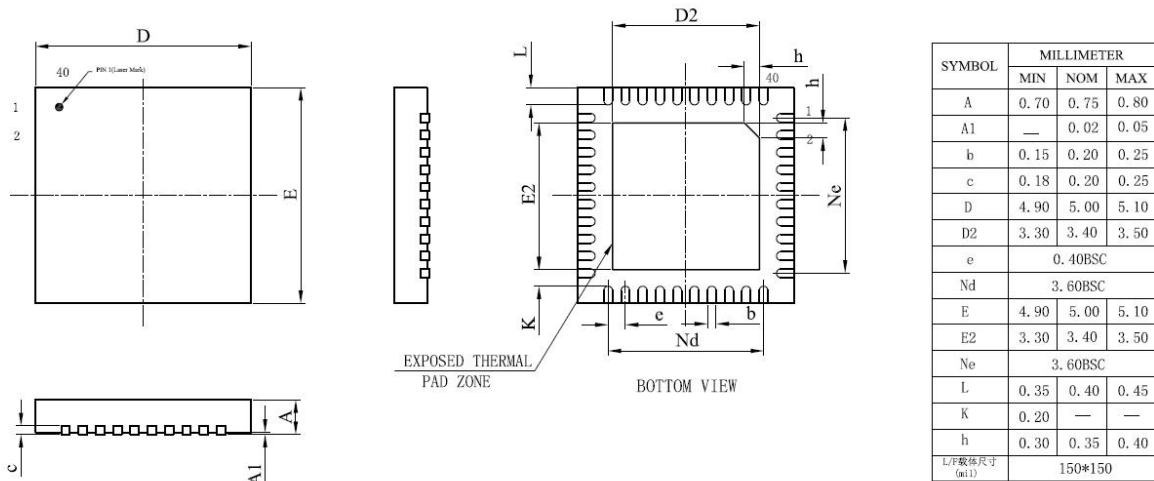

Figure 10-1 Package Information

10.2 Marking information

Figure 10-2 shows AXP2101 marking.



Figure 10-2 AXP2101 Marking

Table 10-1 describes AXP2101 marking information.

Table 10-1 AXP2101 Marking Definitions

No.	Marking	Description	Fixed/Dynamic
1	AXP2101	Product name	Fixed
2	LLLLXX	Lot number	Dynamic
3	XXX1	Date code	Dynamic
4		X-POWERS logo	Fixed
5	White dot	Package pin 1	Fixed

10.3 Carrier

Table 10-2 shows AXP2101 tray carrier information

Table 10-2 Tray Carrier Information

Item	Color	Size
------	-------	------

Aluminum foil bags	Silvery white	540mm x 300mm x 0.14mm
Pearl cotton cushion(Vacuum bag)	White	12mm x 680mm x 185mm
Pearl cotton cushion (The Gap between vacuum bag and inside box)	White	Left-Right:12mm x 180mm x 85mm Front-Back:12mm x 350mm x 70mm
Inside Box	White	396mm x 196mm x 96mm
Outside Box	White	420mm x 410mm x 320mm

Figure 10-3 shows tray dimension drawing of AXP2101.

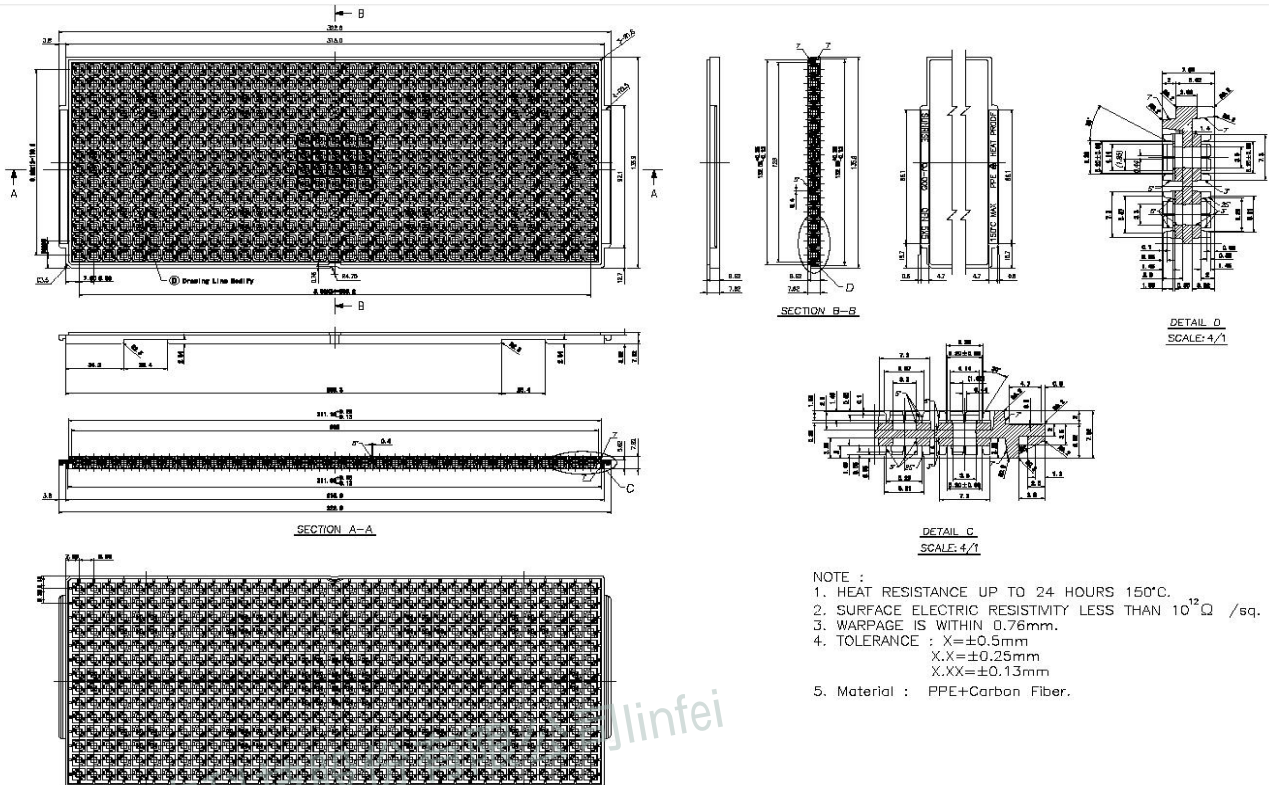

Figure 10-3 Tray Dimension Drawing

Table 10-3 shows AXP2101 packing quantity.

Table 10-3 Packing Quantity Information

Type	Quantity	Part Number
Tray	490pcs/Tray 10Trays/package	AXP2101

10.4 Storage

10.4.1 Moisture Sensitivity Level(MSL)

A package's MSL indicates its ability to withstand exposure after it is removed from its shipment bag, a low MSL device sample can be exposed on the factor floor longer than a high MSL device sample. ALL MSL are defined in Table 10-4.

Table 10-4 MSL Summary

MSL	Out-of-bag floor life	Comments
1	Unlimited	≤30°C/85%RH

2	1 year	≤30°C/60%RH
2a	4 weeks	≤30°C/60%RH
3	168 hours	≤30°C/60%RH
4	72 hours	≤30°C/60%RH
5	48 hours	≤30°C/60%RH
5a	24 hours	≤30°C/60%RH
6	Time on Label(TOL)	≤30°C/60%RH

AXP2101 device samples are classified as MSL3.

10.4.2 Bagged Storage Conditions

The shelf life of AXP2101 are defined in Table 10-5.

Table 10-5

Packing mode	Vacuum packing
Storage temperature	20°C~26°C
Storage humidity	40%~60%RH
Shelf life	6 months

10.4.3 Out-of-bag Duration

It is defined by the device MSL rating. The out-of-bag duration of AXP2101 is as follows.

Table 10-6 Out-of-bag Duration

Storage temperature	20°C~26°C
Storage humidity	40%~60%RH
Moisture Sensitivity Level(MSL)	3
Floor life	168 hours

For no mention of storage rules in this document, please refer to the latest *IPC/JEDEC J-STD-020C*.

10.5 Baking

It is not necessary to bake AXP2101 if the conditions specified in Section 16.4.2 and Section 16.4.3 have not been exceeded. It is necessary to bake AXP2101 if any condition specified in Section 10.4.2 and Section 10.4.3 have been exceeded.

It is necessary to bake AXP2101 if the storage humidity condition has been exceeded. We recommend that the device sample removed from its vacuum bag more than 2 days should be baked to guarantee production.

Table 10-7 Baking Conditions

Surrounding	Bake@125°C	Note
Nitrogen	8 hours	Recommended condition. Not exceed 3 times.
Air	2 hours	Acceptable condition. Not exceed 3 times.

CAUTION: If baking is required, the devices must be transferred into trays that can be baked to at least 125°C. Devices should not be baked in tape and reel carriers at any temperature

11. Reflow Profile

The reflow profile recommended in this document is a lead-free reflow profile that is suitable for pure lead-free technology of lead-free solder paste.

Figure 10-1 shows the typical reflow profile of AXP2101 device sample.

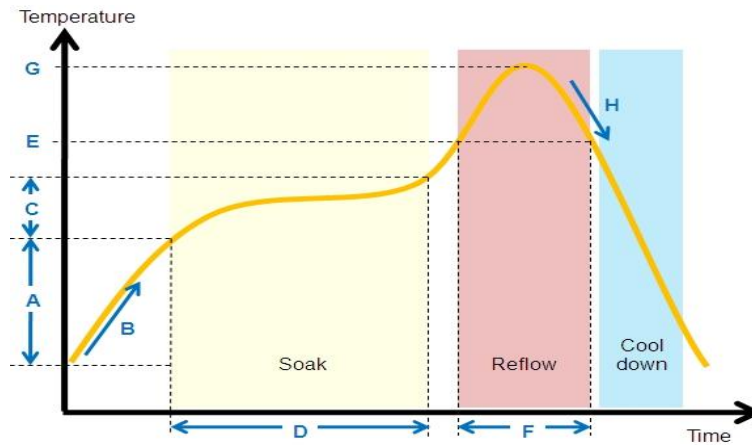

Figure 11-1 AXP2101 Typical Reflow Profile

Reflow profile conditions of AXP2101 device sample is given in Table 11-1.

Table 11-1 AXP2101 Reflow Profile Conditions

QTI typical SMT reflow profile conditions (for reference only)		
	Step	Reflow condition
Environment	N2 purge reflow usage (yes/no)	Yes, N2 purge used
	If yes, O2 ppm level	O2 < 1500 ppm
A	Preheat ramp up temperature range	25°C -> 150°C
B	Preheat ramp up rate	1.5~2.5 °C/sec
C	Soak temperature range	150°C -> 190°C
D	Soak time	80~110 sec
E	Liquidus temperature	217°C
F	Time above liquidus	60-90 sec
G	Peak temperature	240-250°C
H	Cool down temperature rate	≤4°C/sec

珠海全志科技股份有限公司infei

珠海全志科技股份有限公司infei

Declaration

THIS DOCUMENTATION IS THE ORIGINAL WORK AND COPYRIGHTED PROPERTY OF X-POWERS. REPRODUCTION IN WHOLE OR IN PART MUST OBTAIN THE WRITTEN APPROVAL OF X-POWERS AND GIVE CLEAR ACKNOWLEDGEMENT TO THE COPYRIGHT OWNER.

THE PURCHASED PRODUCTS, SERVICES AND FEATURES ARE STIPULATED BY THE CONTRACT MADE BETWEEN X-POWERS AND THE CUSTOMER. PLEASE READ THE TERMS AND CONDITIONS OF THE CONTRACT AND RELEVANT INSTRUCTIONS CAREFULLY BEFORE USING, AND FOLLOW THE INSTRUCTIONS IN THIS DOCUMENTATION STRICTLY. X-POWERS ASSUMES NO RESPONSIBILITY FOR THE CONSEQUENCES OF IMPROPER USE(INCLUDING BUT NOT LIMITED TO OVERVOLTAGE, OVERCLOCK, OR EXCESSIVE TEMPERATURE).

THE INFORMATION FURNISHED BY X-POWERS IS PROVIDED JUST AS A REFERENCE OR TYPICAL APPLICATIONS. ALL STATEMENTS, INFORMATION, AND RECOMMENDATIONS IN THIS DOCUMENT DO NOT CONSTITUTE A WARRANTY OF ANY KIND, EXPRESS OR IMPLIED. X-POWERS RESERVES THE RIGHT TO MAKE CHANGES IN CIRCUIT DESIGN AND/OR SPECIFICATIONS AT ANY TIME WITHOUT NOTICE.

NOR FOR ANY INFRINGEMENTS OF PATENTS OR OTHER RIGHTS OF THE THIRD PARTIES WHICH MAY RESULT FROM ITS USE. NO LICENSE IS GRANTED BY IMPLICATION OR OTHERWISE UNDER ANY PATENT OR PATENT RIGHTS OF X-POWERS. THIRD PARTY LICENCES MAY BE REQUIRED TO IMPLEMENT THE SOLUTION/PRODUCT. CUSTOMERS SHALL BE SOLELY RESPONSIBLE TO OBTAIN ALL APPROPRIATELY REQUIRED THIRD PARTY LICENCES. X-POWERS SHALL NOT BE LIABLE FOR ANY LICENCE FEE OR ROYALTY DUE IN RESPECT OF ANY REQUIRED THIRD PARTY LICENCE. X-POWERS SHALL HAVE NO WARRANTY, INDEMNITY OR OTHER OBLIGATIONS WITH RESPECT TO MATTERS COVERED UNDER ANY REQUIRED THIRD PARTY LICENCE.

珠海全志科技股份有限公司linfei

珠海全志科技股份有限公司linfei

珠海全志科技股份有限公司linfei