



## P2576/HV

## LINEAR INTEGRATED CIRCUIT

### 3A STEP-DOWN VOLTAGE SWITCHING REGULATOR

#### DESCRIPTION

As a step-down (buck) switching regulator, the UTC **P2576/HV** provides drives 3A load. The UTC **P2576/HV** are simple because it only needs to use a minimum number of external components.

Frequency compensation and a fixed-frequency oscillator are in it. UTC **P2576/HV** can perform with standard inductors, and simplifying the switch mode power supplies' design. UTC **P2576/HV** guarantees output load conditions and  $\pm 10\%$  on the oscillator frequency. Its external shutdown is included with 50 $\mu$ A standby current. As well as thermal shutdown for full protection under fault conditions, the output switch has cycle by cycle current limiting.

#### FEATURES

- \* Output Current 3A
- \* Input Voltage Range of 7V to 40V for P2576 and 7V to 60V for P2576HV
- \* Requires 4 External Components
- \* Very High Efficiency
- \* TTL Shutdown
- \* Low Power Standby Mode
- \* Thermal Shutdown,
- \* Current Limit Protection
- \* Internal Oscillator: 52 kHz Fixed Frequency

#### ORDERING INFORMATION

Ordering Number		Package	Packing
Lead Free	Halogen Free		
P2576L-xx-TA5-T	P2576G-xx-TA5-T	TO-220-5	Tube
P2576L-xx-TB5-T	P2576G-xx-TB5-T	TO-220B	Tube
P2576L-xx-TQ5-R	P2576G-xx-TQ5-R	TO-263-5	Tape Reel
P2576L-xx-TQ5-T	P2576G-xx-TQ5-T	TO-263-5	Tube
P2576L-xx-S08-R	P2576G-xx-S08-R	SOP-8	Tape Reel
P2576L-xx-SH2-R	P2576G-xx-SH2-R	HSOP-8	Tape Reel
P2576HVL-xx-TQ5-R	P2576HVG-xx-TQ5-R	TO-263-5	Tape Reel
P2576HVL-xx-TQ5-T	P2576HVG-xx-TQ5-T	TO-263-5	Tube

Note: xx: Output Voltage, refer to Marking Information.

<p>P2576XXG-xx-TQ5-T</p> <ul style="list-style-type: none"> <li>(1)Packing Type</li> <li>(2)Package Type</li> <li>(3)Output Voltage Code</li> <li>(4)Green Package</li> <li>(5)Supply Voltage Code</li> </ul>	<ul style="list-style-type: none"> <li>(1) T: Tube, R: Tape Reel</li> <li>(2) TA5: TO-220-5, TB5: TO-220B, TQ5: TO-263-5</li> <li>S08: SOP-8, SH2: HSOP-8</li> <li>(3) xx: refer to Marking Information</li> <li>(4) G: Halogen Free and Lead Free, L: Lead Free</li> <li>(5) Blank: 40V, HV: 60V</li> </ul>
---	--

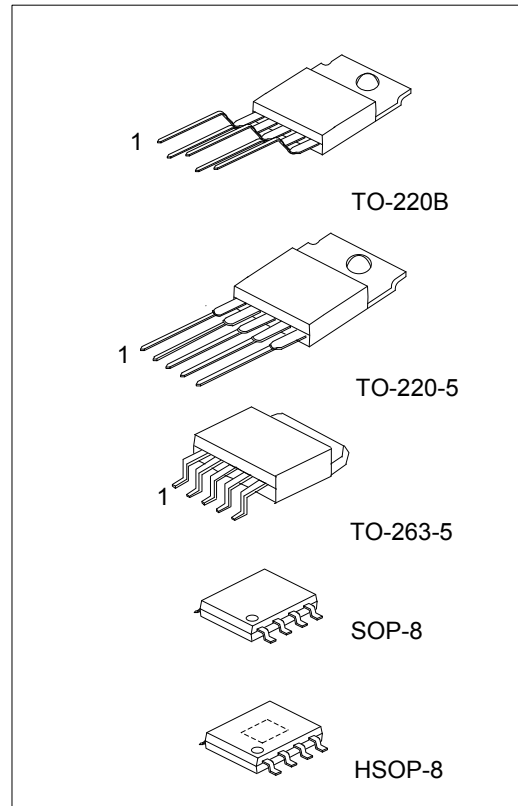

### MARKING INFORMATION

PACKAGE	VOLTAGE CODE	MARKING
<b>P2576</b>		
TO-220B TO-220-5 TO-263-5	50:5.0V 33:3.3V 12:12V 15:15V	<p>UTC P2576 XX Voltage Code Date Code L : Lead Free G: Halogen Free 1 2 3 4 5</p>
SOP-8 HSOP-8	AD:ADJ	<p>UTC P2576 Voltage Code Date Code L : Lead Free G: Halogen Free Lot Code 8 7 6 5 1 2 3 4</p>
<b>P2576HV</b>		
TO-263-5	50:5.0V 33:3.3V 12:12V 15:15V AD:ADJ	<p>UTC P2576HV XX Voltage Code Date Code L : Lead Free G: Halogen Free 1 2 3 4 5</p>

## ■ PIN CONFIGURATION

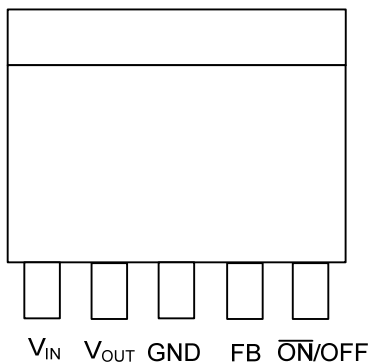

TO-220B/TO-220-5/TO-263-5

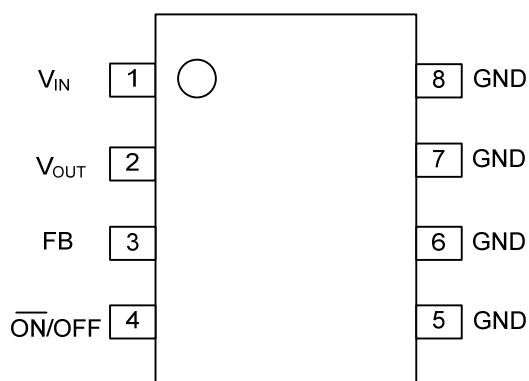

SOP-8

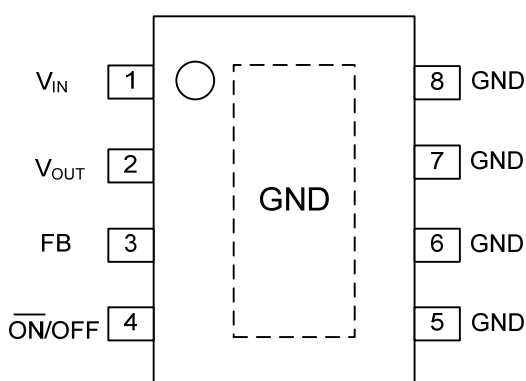

HSOP-8

## ■ PIN DESCRIPTIONS

### For SOP-8/HSOP-8

PIN NO.	PIN NAME	PIN DESCRIPTION
1	$V_{IN}$	Input voltage
2	$V_{OUT}$	Output voltage
3	FB	Feed back.
4	$\overline{ON/OFF}$	$\overline{ON/OFF}$ select pin, when connected to the ground the chip in operating normally. $\overline{ON/OFF}$ pin can't floating.
5,6,7,8	GND	Ground

### For TO-220B/TO-220-5/TO-263-5

PIN NO.	PIN NAME	PIN DESCRIPTION
1	$V_{IN}$	Input voltage
2	$V_{OUT}$	Output voltage
3	GND	Ground
4	FB	Feed back.
5	$\overline{ON/OFF}$	$\overline{ON/OFF}$ select pin, when connected to the ground the chip in operating normally. $\overline{ON/OFF}$ pin can't floating.

■ BLOCK DIAGRAM

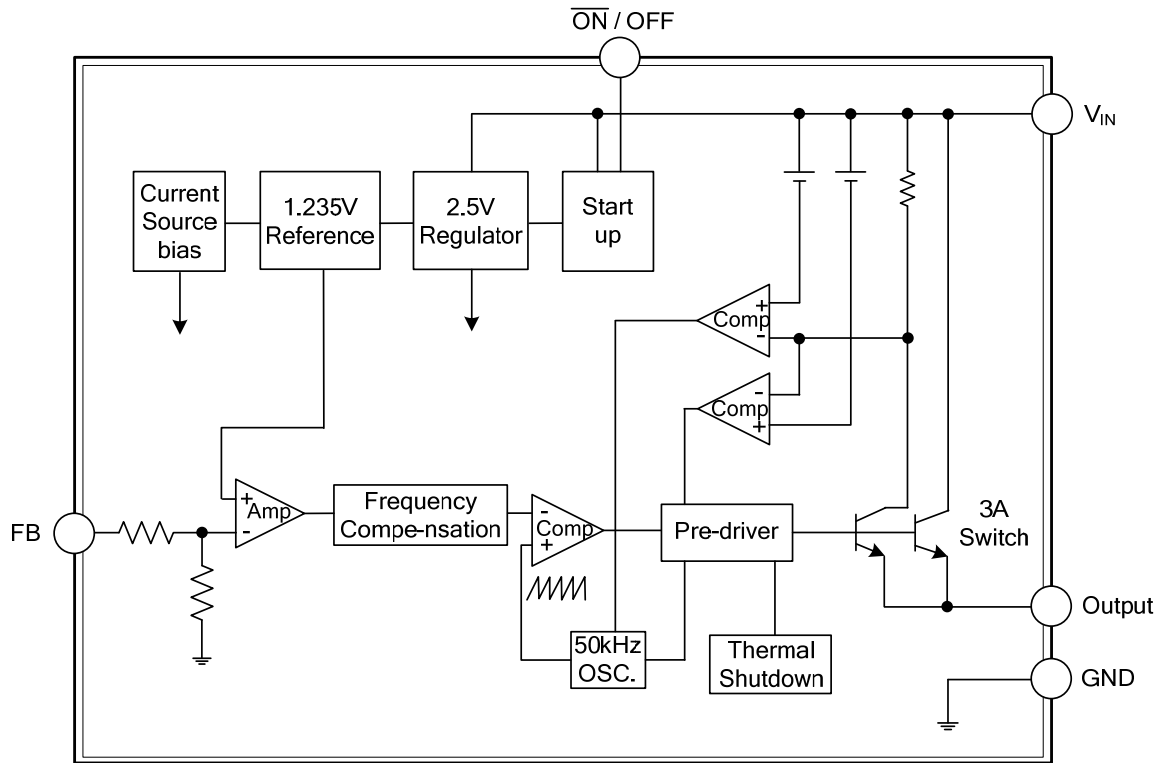

■ ABSOLUTE MAXIMUM RATINGS (T<sub>A</sub>=25°C, unless otherwise specified)

PARAMETER	SYMBOL	RATINGS	UNITS
Supply Voltage	P2576	40	V
	P2576HV	60	V
Maximum Supply Voltage	P2576	45	V
	P2576HV	65	V
ON/OFF Pin Input Voltage	V <sub>ON/OFF</sub>	-0.3 ~ V <sub>IN</sub>	V
Output Voltage to Ground (Steady State)	V <sub>OUT</sub>	-1.0	V
Power Dissipation	P <sub>D</sub>	Internally Limited	mW
Junction Temperature	T <sub>J</sub>	+150	°C
Operating Temperature	T <sub>OPR</sub>	-40 ~ +125	°C
Storage Temperature	T <sub>STG</sub>	-65 ~ +150	°C

Note: Absolute maximum ratings are those values beyond which the device could be permanently damaged. Absolute maximum ratings are stress ratings only and functional device operation is not implied.

■ ELECTRICAL CHARACTERISTICS

(T<sub>J</sub>=25°C, When V<sub>OUT</sub> = 3.3V & 5V & ADJ, V<sub>IN</sub> = 12V ; V<sub>OUT</sub> = 12V, V<sub>IN</sub> = 15V · V<sub>OUT</sub> = 15V, V<sub>IN</sub> = 18V, I<sub>LOAD</sub>=500mA, unless otherwise specified)

PARAMETER	SYMBOL	TEST CONDITIONS	MIN	TYP	MAX	UNIT	
Feedback Voltage	3.3V	V <sub>OUT</sub>	7V ≤ V <sub>IN</sub> ≤ 40V, 0.5A ≤ I <sub>LOAD</sub> ≤ 3A	3.17	3.3	3.43	V
	5.0V		8V ≤ V <sub>IN</sub> ≤ 40V, 0.5A ≤ I <sub>LOAD</sub> ≤ 3A	4.8	5.0	5.2	V
	12V		15V ≤ V <sub>IN</sub> ≤ 40V, 0.5A ≤ I <sub>LOAD</sub> ≤ 3A	11.52	12.0	12.48	V
	15V		18V ≤ V <sub>IN</sub> ≤ 40V, 0.5A ≤ I <sub>LOAD</sub> ≤ 3A	14.4	15	15.6	V
Efficiency	3.3V	η	V <sub>IN</sub> =9V, I <sub>LOAD</sub> =3A		70		%
	5.0V		V <sub>IN</sub> =12V, I <sub>LOAD</sub> =3A		77		%
	12V		V <sub>IN</sub> =15V, I <sub>LOAD</sub> =3A		88		%
	15V		V <sub>IN</sub> =18V, I <sub>LOAD</sub> =3A		88		%

**P2576/HV - ADJ**

Feedback Voltage	V <sub>FB</sub>	V <sub>IN</sub> =12V, I <sub>LOAD</sub> =0.5A, V <sub>OUT</sub> =5V	1.180	1.23	1.279	V
		8V ≤ V <sub>IN</sub> ≤ 40V, 0.5A ≤ I <sub>LOAD</sub> ≤ 3.0A, V <sub>OUT</sub> =5V	1.180	1.23	1.279	V
Efficiency	η	V <sub>IN</sub> = 12 V, I <sub>LOAD</sub> = 3.0 A, V <sub>OUT</sub> = 5V		77		%

**ALL OUTPUT VOLTAGE**

Oscillator Frequency	f <sub>OSC</sub>	(Note 4)	42	52	63	kHz
Saturation Voltage	V <sub>SAT</sub>	I <sub>OUT</sub> =3A (Note 1)		1.4	1.8	V
Max Duty Cycle (ON)	DC	(Note 2)	93	98		%
Current Limit	I <sub>LIMIT</sub>	(Note 1, 4)	3.5	5.8	6.9	A
Output Leakage Current	I <sub>I(LEAK)</sub>	V <sub>IN</sub> =40V, Output=-1V (Notes 3)			30	mA
		Output=0V			200	μA
Quiescent Current	I <sub>Q</sub>	(Note 3)		5	10	mA
Standby Quiescent Current	I <sub>STBY</sub>	ON/OFF Pin=5V (OFF)		50	200	μA
ON/OFF Pin Logic Input Level	V <sub>IH</sub>	V <sub>OUT</sub> =0V	2.2			V
	V <sub>IL</sub>	V <sub>OUT</sub> =Nominal Output Voltage			1.0	V
ON/OFF Pin Input Current	I <sub>IH</sub>	ON/OFF Pin=5V (OFF)		12	30	μA
	I <sub>IL</sub>	ON/OFF Pin=0V (ON)		0	10	μA

Notes: 1. Output pin sourcing current. No diode, inductor or capacitor connected to output.

2. Feedback pin removed from output and connected to 0V.

3. Feedback pin removed from output and connected to +12V, to force the output transistor OFF.

4. The oscillator frequency reduces to approximately 11 kHz in the event of an output short or an overload which causes the regulated output voltage to drop approximately 40% from the nominal output voltage.

This self-protection feature lowers the Average power dissipation of **P2576/HV** by lowering the minimum duty cycle from 5% down to approximately 2%.

## ■ APPLICATION CIRCUIT

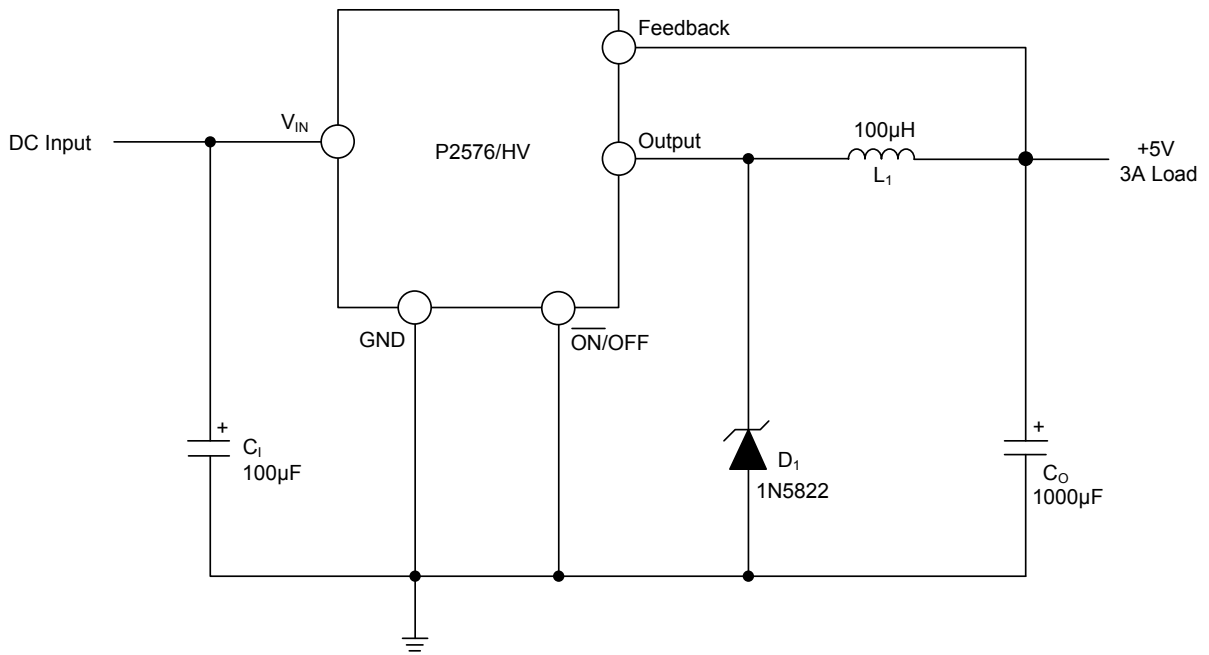

## ■ TYPICAL TEST CIRCUIT

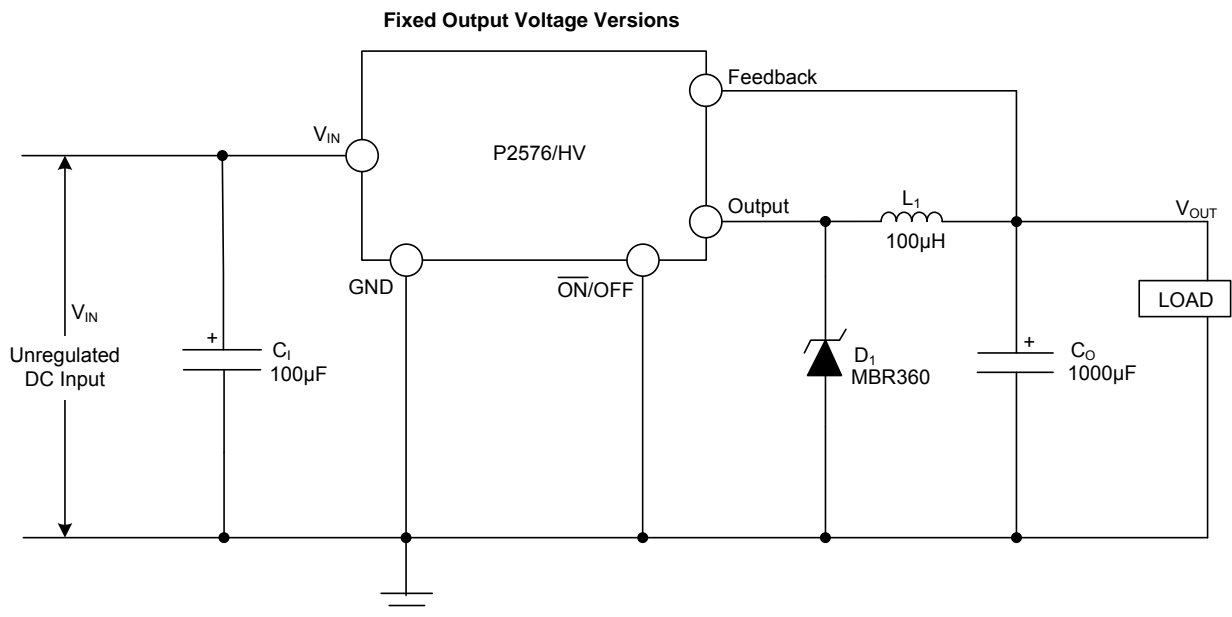

$C_1$  : 100µF, 75V  
 $C_0$  : 680µF, 25V  
 $D_1$  : Schottky, MBR360  
 $L_1$  : 100µH  
 $R_1$  : 2K, 0.1%  
 $R_2$  : 6.12K, 0.1%

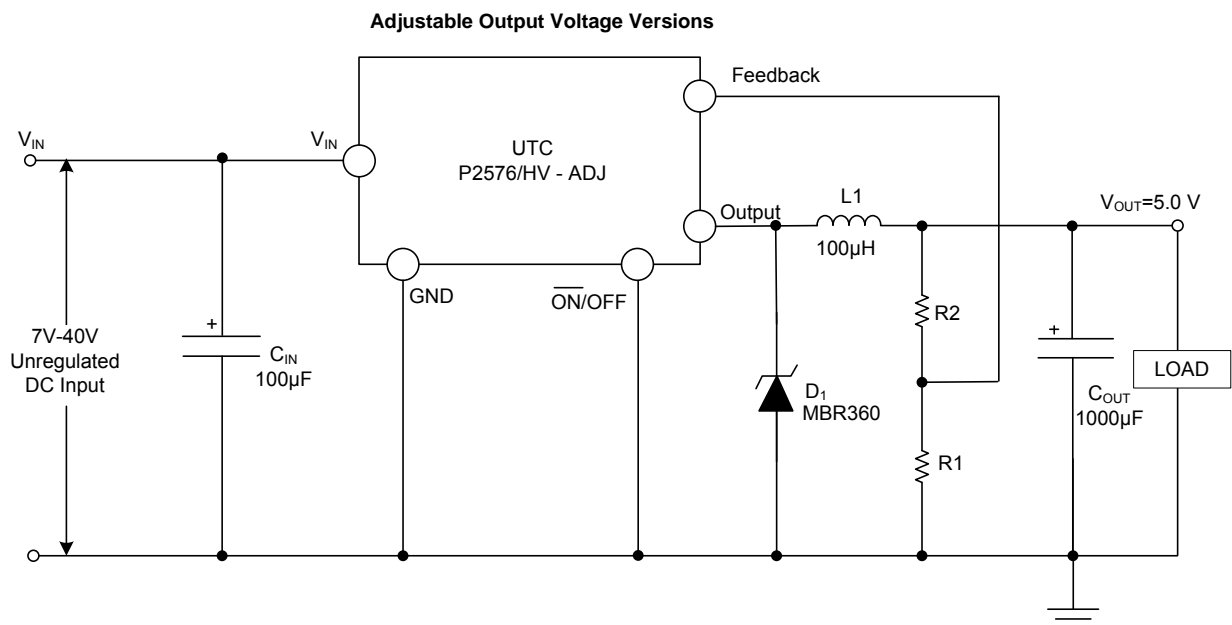

Note:  $V_{OUT} = V_{REF} \left(1 + \frac{R_2}{R_1}\right)$

$$R_2 = R_1 \left(\frac{V_{OUT}}{V_{REF}} - 1\right)$$

(Where  $V_{REF}=1.23V$ ,  $R_1$  between 1k and 5k.)

■ TYPICAL APPLICATION CIRCUIT ( $T_A=25^\circ\text{C}$ ,  $V_{CC}=12\text{V}$ , unless otherwise specified)

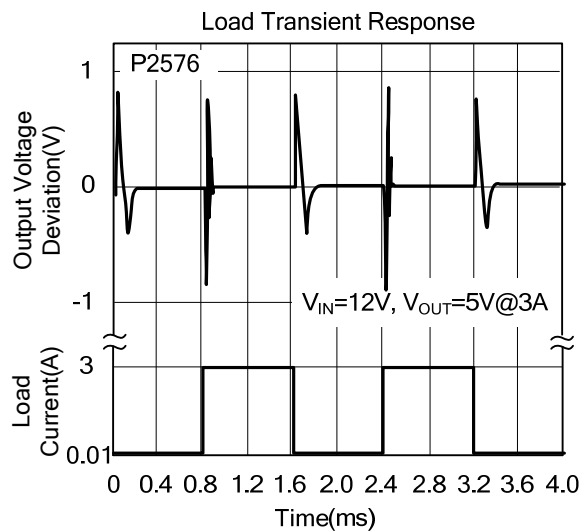
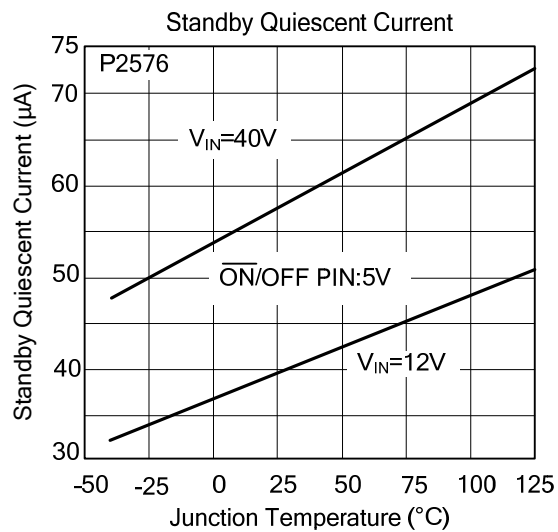
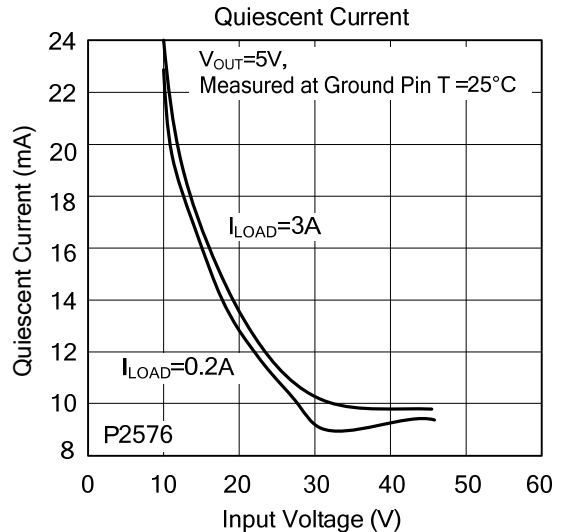
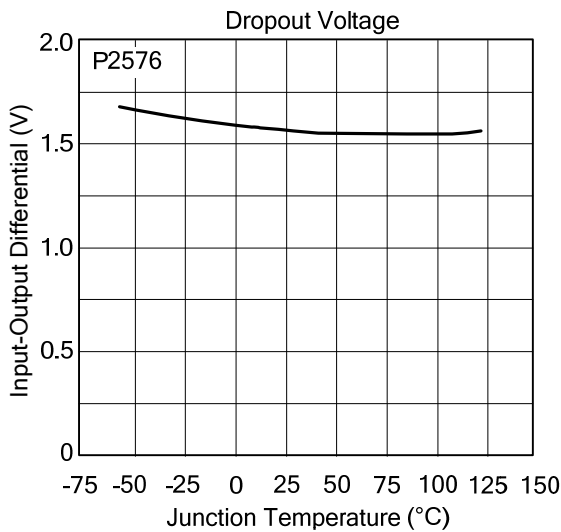
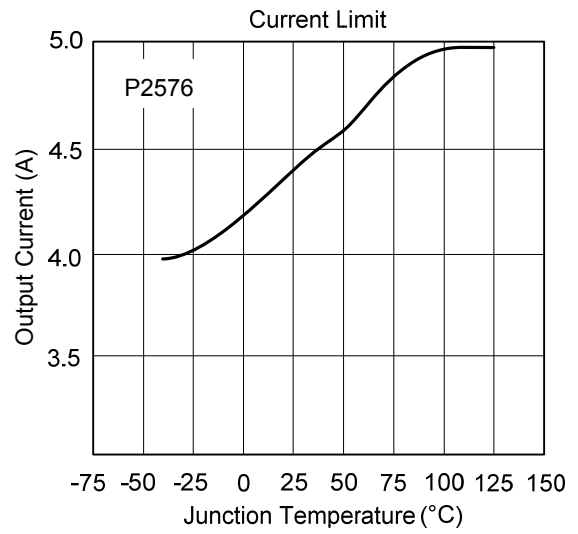
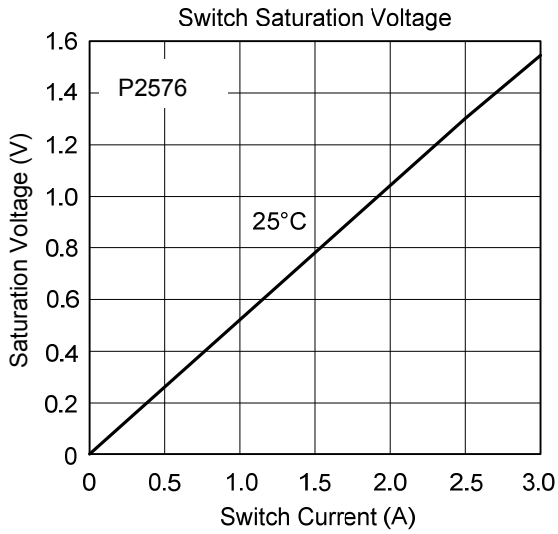



■ TYPICAL APPLICATION CIRCUIT(Cont.)

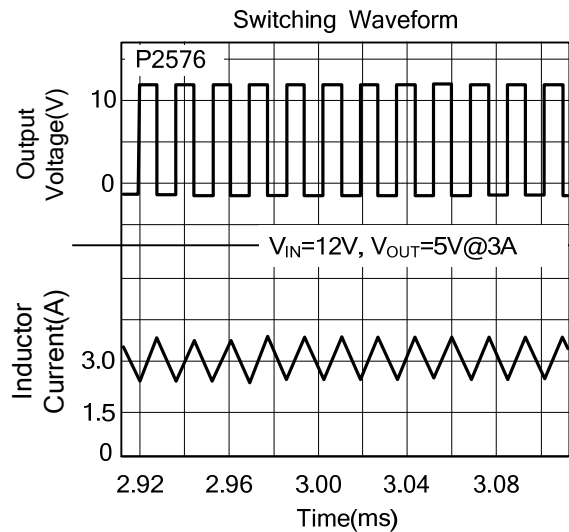
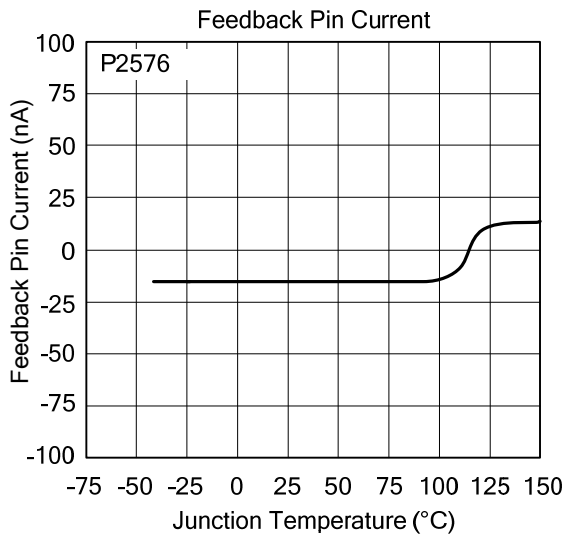
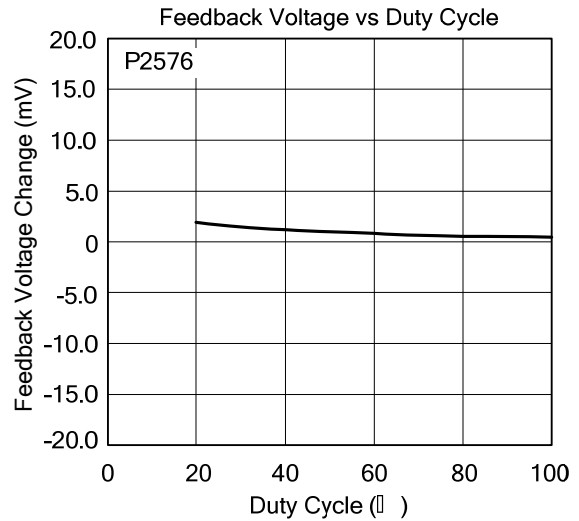
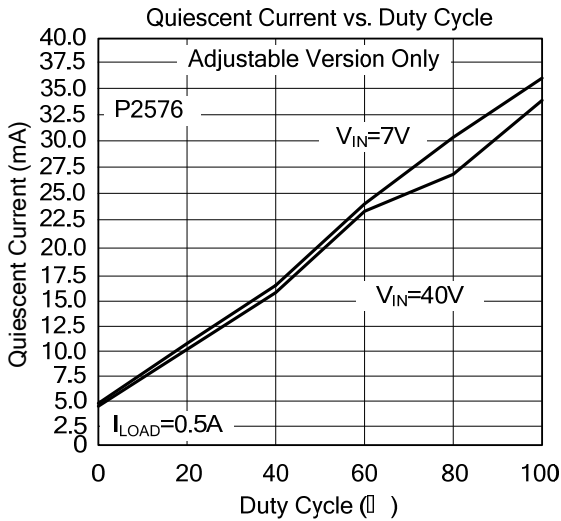

UTC assumes no responsibility for equipment failures that result from using products at values that exceed, even momentarily, rated values (such as maximum ratings, operating condition ranges, or other parameters) listed in products specifications of any and all UTC products described or contained herein. UTC products are not designed for use in life support appliances, devices or systems where malfunction of these products can be reasonably expected to result in personal injury. Reproduction in whole or in part is prohibited without the prior written consent of the copyright owner. UTC reserves the right to make changes to information published in this document, including without limitation specifications and product descriptions, at any time and without notice. This document supersedes and replaces all information supplied prior to the publication hereof.