



LR9102/A

CMOS IC

LOW NOISE 300mA LDO REGULATOR

DESCRIPTION

The UTC **LR9102/A** is a typical LDO (linear regulator) with the features of high output voltage accuracy, low supply current, low ON-resistance, and high ripple rejection.

During operation of the UTC **LR9102/A**, the dropout voltage is very low and the response of line transient and load transient are very well.

Internally, there're many functions of UTC **LR9102/A** which can be seen in the block figure. There are a voltage reference unit, an error amplifier, resistor-net for voltage setting, a current limit circuit, and a chip enable circuit in each UTC **LR9102/A**, with auto discharge function at off state.

The UTC **LR9102/A** can be used as an ideal of the power supply for hand-held communication equipment, such as: power source for portable communication equipment, power source for electrical appliances, for example, cameras, VCRs and camcorders and power source for battery-powered equipment.

FEATURES

- * Ultra Supply Current: LR9102: 50μA (Typ.)
LR9102A: 90μA (Typ.)
- * Standby Mode: 0.1μA (Typ.)
- * Very Low Dropout Voltage: 0.12V (Typ.)
@ I_{OUT} = 300mA, V_{OUT} = 2.85V
- * Ripple Rejection: 75dB (Typ.)
@ f = 1kHz, V_{OUT} = 2.85V
- * Temperature-Drift Coefficient of Output Voltage: ±50ppm/°C (Typ.)
- * Well Line Regulation: 0.02%/V (Typ.)
- * Output Voltage Accuracy: ±1.0%
- * Internal Fold Back Protection Circuit: 50mA (Typ.) @ short mode
- * C_{IN}=C_{OUT}=1μF or more (Ceramic capacitors) are recommended to be used with this IC

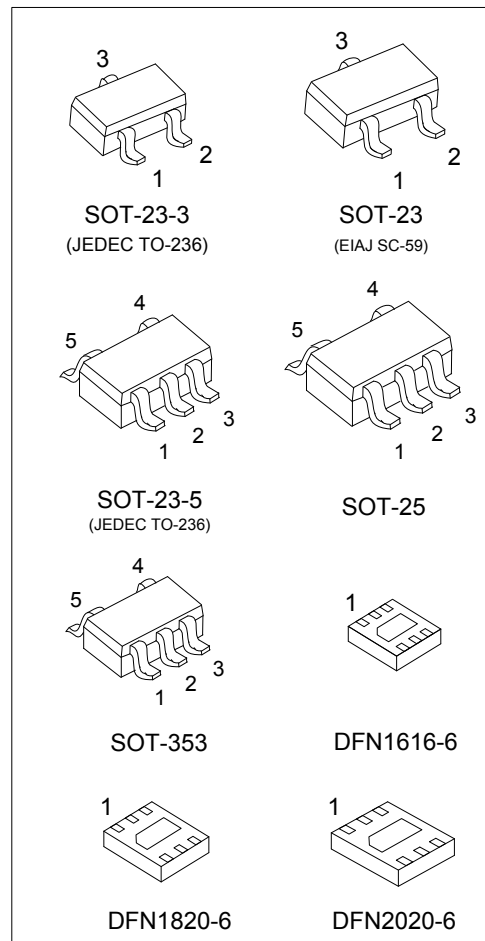

ORDERING INFORMATION

Ordering Number		Package	Packing
Lead Free	Halogen Free		
LR9102L-xx-AE2-R	LR9102G-xx-AE2-R	SOT-23-3	Tape Reel
LR9102L-xx-AE5-R	LR9102G-xx-AE5-R	SOT-23-5	Tape Reel
LR9102L-xx-AF5-R	LR9102G-xx-AF5-R	SOT-25	Tape Reel
LR9102L-xx-AL5-R	LR9102G-xx-AL5-R	SOT-353	Tape Reel
LR9102L-xx-K06-1616-R	LR9102G-xx-K06-1616-R	DFN1616-6	Tape Reel
LR9102L-xx-K06-1820-R	LR9102G-xx-K06-1820-R	DFN1820-6	Tape Reel
LR9102AL-xx-AE2-R	LR9102AG-xx-AE2-R	SOT-23-3	Tape Reel
LR9102L-xx-AE3-R	LR9102G-xx-AE3-R	SOT-23	Tape Reel
LR9102AL-xx-AE5-R	LR9102AG-xx-AE5-R	SOT-23-5	Tape Reel
LR9102AL-xx-AF5-R	LR9102AG-xx-AF5-R	SOT-25	Tape Reel
LR9102AL-xx-AL5-R	LR9102AG-xx-AL5-R	SOT-353	Tape Reel
LR9102AL-xx-K06-1616-R	LR9102AG-xx-K06-1616-R	DFN1616-6	Tape Reel
LR9102AL-xx-K06-1820-R	LR9102AG-xx-K06-1820-R	DFN1820-6	Tape Reel
LR9102AL-xx-K06-2020-R	LR9102AG-xx-K06-2020-R	DFN2020-6	Tape Reel

Note: xx: Output Voltage, refer to Marking Information.

<p>LR9102AG-xx-AE2-R</p>	<p>(1) R: Tape Reel (2) AE2: SOT-23-3, AE3: SOT-23, AE5: SOT-23-5, AF5: SOT-25, AL5: SOT-353, K06-1616: DFN1616-6, K06-1820: DFN1820-6, K06-2020: DFN2020-6 (3) xx: refer to Marking Information (4) G: Halogen Free and Lead Free, L: Lead Free (5) refer to ELECTRICAL CHARACTERISTICS</p>
--------------------------	--

MARKING INFORMATION

PACKAGE	VOLTAGE CODE	MARKING	
		LR9102	LR9102A
SOT-23-3 SOT-23	10: 1.0V 11: 1.1V 12: 1.2V 13: 1.3V		
SOT-23-5 SOT-25 SOT-353	15: 1.5V 18: 1.8V 25: 2.5V 27: 2.7V 28: 2.8V 2J: 2.85V		
DFN1616-6 DFN1820-6 DFN2020-6	29: 2.9V 30: 3.0V 33: 3.3V 36: 3.6V		

PIN CONFIGURATION

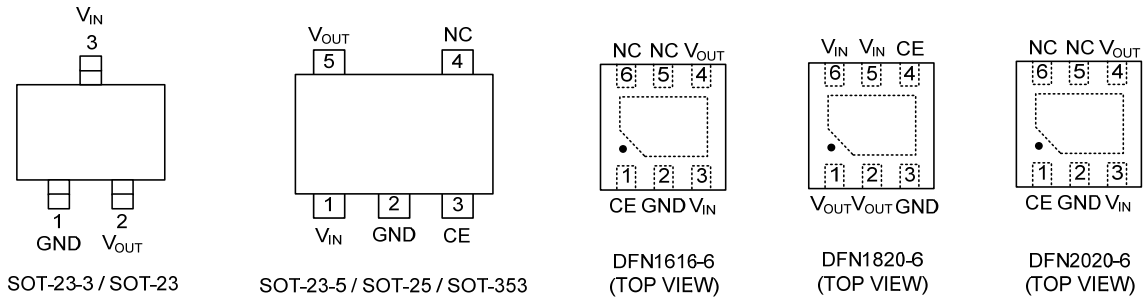

PIN DESCRIPTION

PIN NO.				PIN NAME	DESCRIPTION
SOT-23-3 SOT-23	SOT-23-5 SOT-25 SOT-353	DFN1616-6 DFN2020-6	DFN1820-6		
3	1	3	5, 6	V_{IN}	Input Pin
1	2	2	3	GND	Ground Pin
-	3	1	4	CE	Chip Enable Pin. Active when this Pin is high.
-	4	5, 6	-	NC	No Connection
2	5	4	1, 2	V_{OUT}	Output Pin

BLOCK DIAGRAM

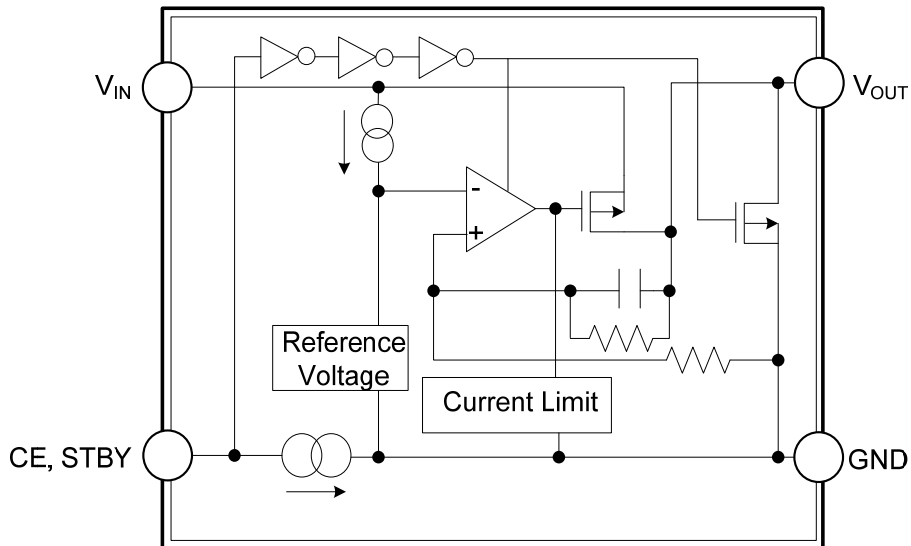

■ ABSOLUTE MAXIMUM RATING

PARAMETER		SYMBOL	RATINGS	UNIT
Input Voltage		V_{IN}	6	V
Input Voltage (CE Pin)		V_{CE}	6	V
Output Voltage		V_{OUT}	$V_{IN}+0.3$	V
Output Current		I_{OUT}	400	mA
Power Dissipation	SOT-23-3/SOT-23	P_D	280	mW
	SOT-23-5/SOT-25		300	mW
	SOT-353			
	DFN1616-6			
	DFN1820-6			
DFN2020-6	1100 (Note 2)	mW		
Junction Temperature		T_J	+125	°C
Operating Temperature		T_{OPR}	-40 ~ +125	°C
Storage Temperature		T_{STG}	-55 ~ +125	°C

Notes: 1. Absolute maximum ratings are those values beyond which the device could be permanently damaged.

Absolute maximum ratings are stress ratings only and functional device operation is not implied.

2. The data tested by surface mounted on a 2 inch² FR-4 board with 2OZ copper.

■ ELECTRICAL CHARACTERISTICS

($T_A=25^\circ\text{C}$, $V_{IN}=\text{Set } V_{OUT}+1\text{V}$, $I_{OUT}=1\text{mA}$, $C_i=C_o=1\mu\text{F}$, unless otherwise specified)

PARAMETER		SYMBOL	TEST CONDITIONS	MIN	TYP	MAX	UNIT
Output Voltage		V_{OUT}	$V_{IN} = \text{Set } V_{OUT}+1\text{V}$	$V_{OUT} > 2.0\text{V}$	×0.99	×1.01	V
				$V_{OUT} \leq 2.0\text{V}$	-20	+20	mV
Input Voltage		V_{IN}				6	V
Load Regulation		ΔV_{OUT}	$1\text{mA} \leq I_{OUT} \leq 150\text{mA}$		20	40	mV
Output Current		I_{OUT}		300			mA
Supply Current		I_{SS}	$I_{OUT}=0\text{A}$	LR9102	50	90	μA
				LR9102A	90	130	μA
Supply Current (Standby)		I_{ST-BY}	$V_{CE}=0\text{V}$		0.1	2	μA
Short Current Limit		I_{LIMIT}	$V_{OUT}=0\text{V}$		50		mA
CE Pull-down Current		I_{PD}			0.3		μA
CE Input Voltage	High	V_{CEH}		1.2			V
	Low	V_{CEL}				0.3	V
Output Noise		eN	$B_W=10\text{Hz to } 100\text{kHz}$, $I_{OUT}=30\text{mA}$		30		μVrms
Ripple Rejection		RR	$f=1\text{kHz}$, Ripple 0.2V_{P-P} $V_{IN}=\text{Set } V_{OUT}+1\text{V}$, $I_{OUT}=30\text{mA}$ (In case that $V_{OUT}=2.0\text{V}$, $V_{IN}=3\text{V}$)		75		dB
Dropout Voltage		V_D	$I_{OUT}=300\text{mA}$	$1.0\text{V} \leq V_{OUT} < 1.2\text{V}$	0.60	1.00	V
				$1.2\text{V} \leq V_{OUT} < 1.5\text{V}$	0.38	0.70	
				$1.5\text{V} \leq V_{OUT} < 1.7\text{V}$	0.30	0.40	
				$1.7\text{V} \leq V_{OUT} < 2.0\text{V}$	0.20	0.28	
				$2.0\text{V} \leq V_{OUT} < 2.5\text{V}$	0.17	0.24	
				$2.5\text{V} \leq V_{OUT} < 2.8\text{V}$	0.14	0.20	
Line Regulation		$\frac{\Delta V_{OUT}}{\Delta V_{IN}}$	$1.0\text{V} \leq V_{OUT} \leq 4.0\text{V}$, $V_{SET}+0.5\text{V} \leq V_{IN} \leq 5\text{V}$	0.02	0.10	%V	
			$4.0\text{V} < V_{OUT} \leq 5.0\text{V}$, $V_{SET}+0.5\text{V} \leq V_{IN} \leq 6.5\text{V}$				
Output Voltage Temperature Coefficient		$\frac{\Delta V_{OUT}}{\Delta T}$	$-40^\circ\text{C} \leq T_{OPR} \leq 85^\circ\text{C}$		±50		ppm/°C
Low Output Nch Tr. ON Resistance		R_{LOW}	$V_{IN}=4.0\text{V}$, $V_{CE}=0\text{V}$		70		Ω

■ TEST CIRCUIT

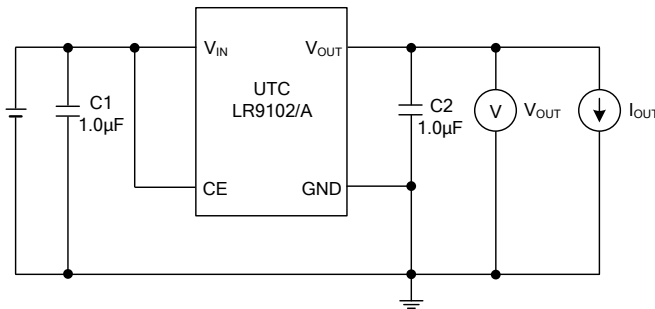

Basic Test Circuit

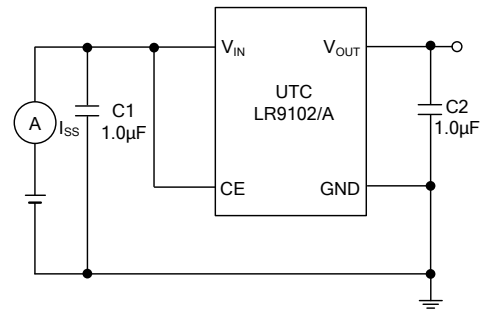

Test Circuit for Supply Current

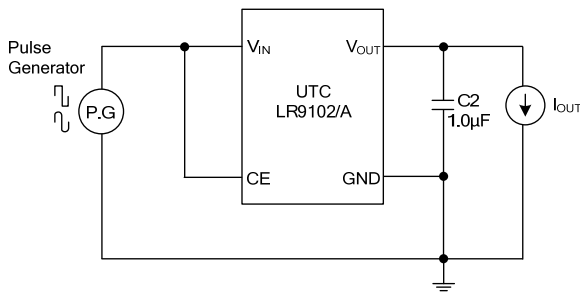

Test Circuit for Ripple Rejection

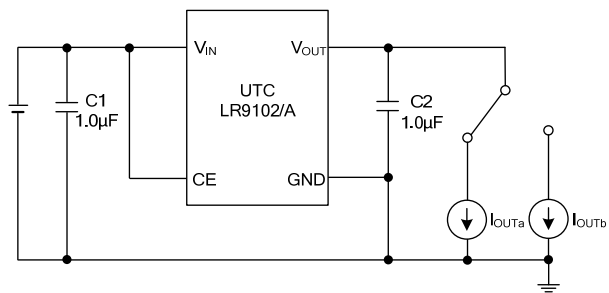

Test Circuit for Load Transient Response

■ TYPICAL APPLICATION CIRCUIT

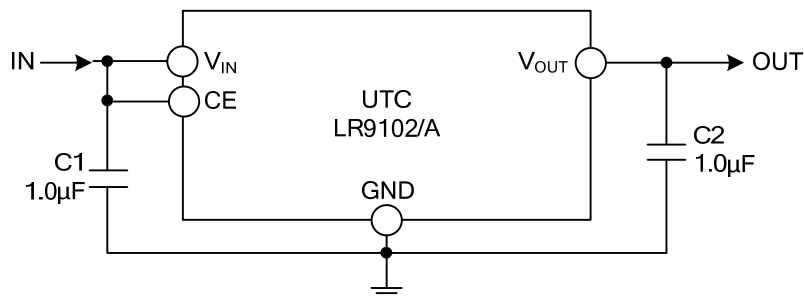

UTC assumes no responsibility for equipment failures that result from using products at values that exceed, even momentarily, rated values (such as maximum ratings, operating condition ranges, or other parameters) listed in products specifications of any and all UTC products described or contained herein. UTC products are not designed for use in life support appliances, devices or systems where malfunction of these products can be reasonably expected to result in personal injury. Reproduction in whole or in part is prohibited without the prior written consent of the copyright owner. UTC reserves the right to make changes to information published in this document, including without limitation specifications and product descriptions, at any time and without notice. This document supersedes and replaces all information supplied prior to the publication hereof.